

33 KEYBOARD

GENERAL DESCRIPTION AND PRINCIPLES OF OPERATION

CONTENTS	PAGE
1. GENERAL	1
2. TECHNICAL DATA	1
3. ASCII	4
4. OUTLINE OF OPERATION	4
5. DETAILED OPERATION	4
A. Codebar Mechanism	4
B. Universal Codebar Mechanism . .	5
C. Keyboard Contact Mechanism . . .	6
D. Line Break	7
E. Repeat	7
F. HERE IS	7
G. Keyboard — Typing Unit Interface	7
H. Nonparity Operation	7
I. Parity Operation	9
6. KEYBOARDS FOR 3300 SERIES CODED SETS AND COMPUTER INPUT/OUTPUT SETS	12
KEYBOARDS FOR 3300 SERIES CODED SETS	12
KEYBOARDS FOR COMPUTER INPUT/OUTPUT SETS	13
7. NUMERIC KEYBOARD	14

1.02 Both the nonparity (Figure 1) and parity keyboards (Figure 2) are covered in this section.

1.03 The 33 nonparity and parity keyboards are electromechanical apparatus used to mechanically select and electrically transmit ASCII (American National Standard Code for Information Interchange).

1.04 The functional difference between the nonparity and parity keyboards is in the control of the eighth level pulse:

(a) With nonparity keyboards the eighth pulse is always marking.

(b) With parity keyboards the eighth pulse changes so that an even number of marking pulses is transmitted for every character.

Note: For further details on ASCII and transmission principles refer to Section 574-122-100TC covering the 33 Typing Unit.

1.05 References to left, right, front, rear, etc consider the keyboard as viewed by the operator.

1.06 In the illustrations fixed pivots are solid black, and floating pivots — those mounted on parts that move — are crosshatched.

CAUTION: DISCONNECT ALL POWER FROM THE KEYBOARD PRIOR TO INSPECTION.

1. GENERAL

1.01 This section provides general description and principles of operation for the 33 keyboard. It is reissued to include keyboards for the 3300 Series Coded Sets and for Computer Input/Output (I/O) Sets, to include the numeric keyboard, and to incorporate engineering changes. Marginal arrows indicate changes and additions. However, marginal arrows have been omitted from Parts 6 and 7 because all information in these two parts is new.

2. TECHNICAL DATA

Note: This equipment is intended to be operated in a room environment within the temperature range of 40°F to 110°F. Serious damage to it could result if this range is exceeded. In this connection, particular caution should be exercised in using acoustical and other enclosures.

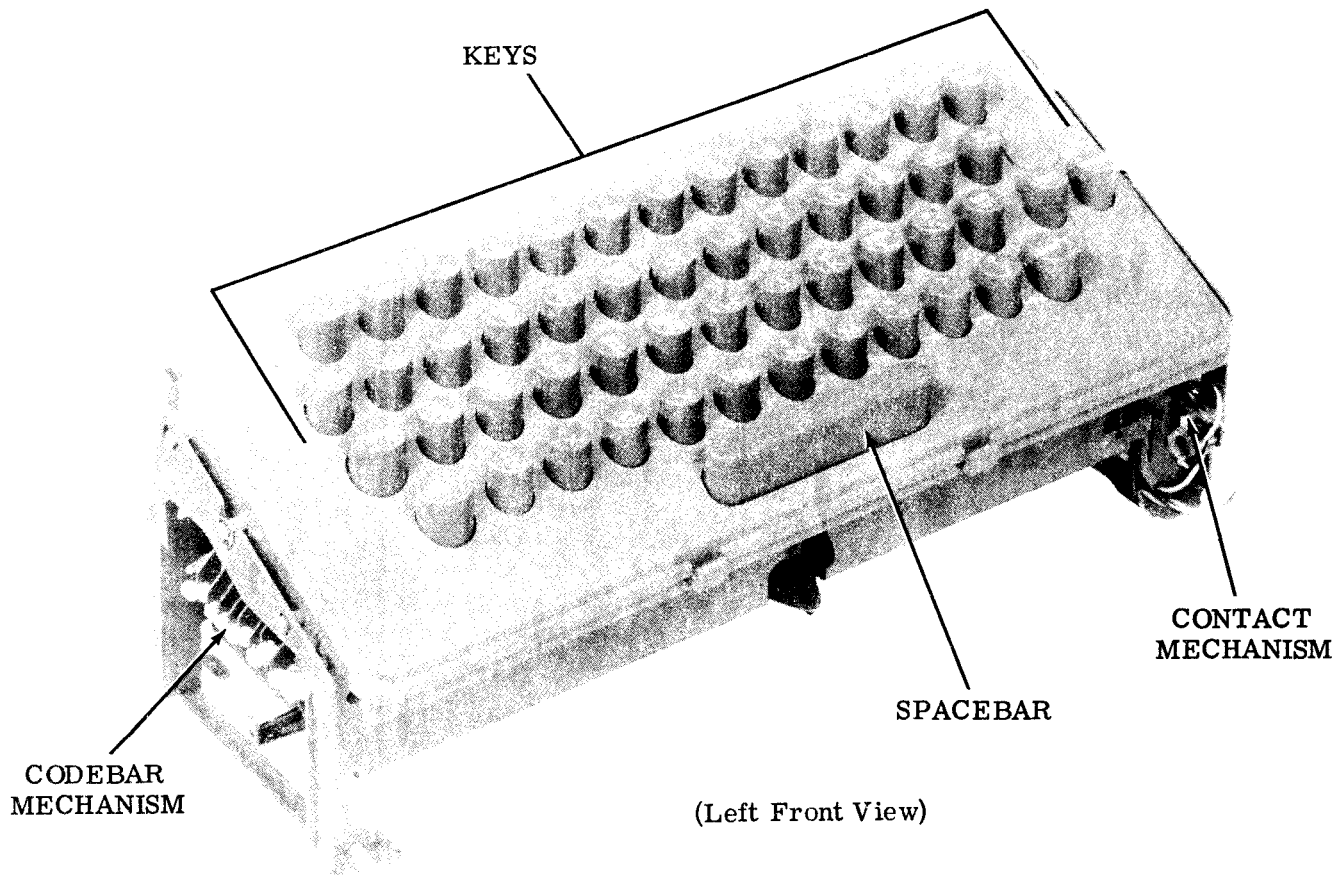

Figure 1 - Nonparity Keyboard

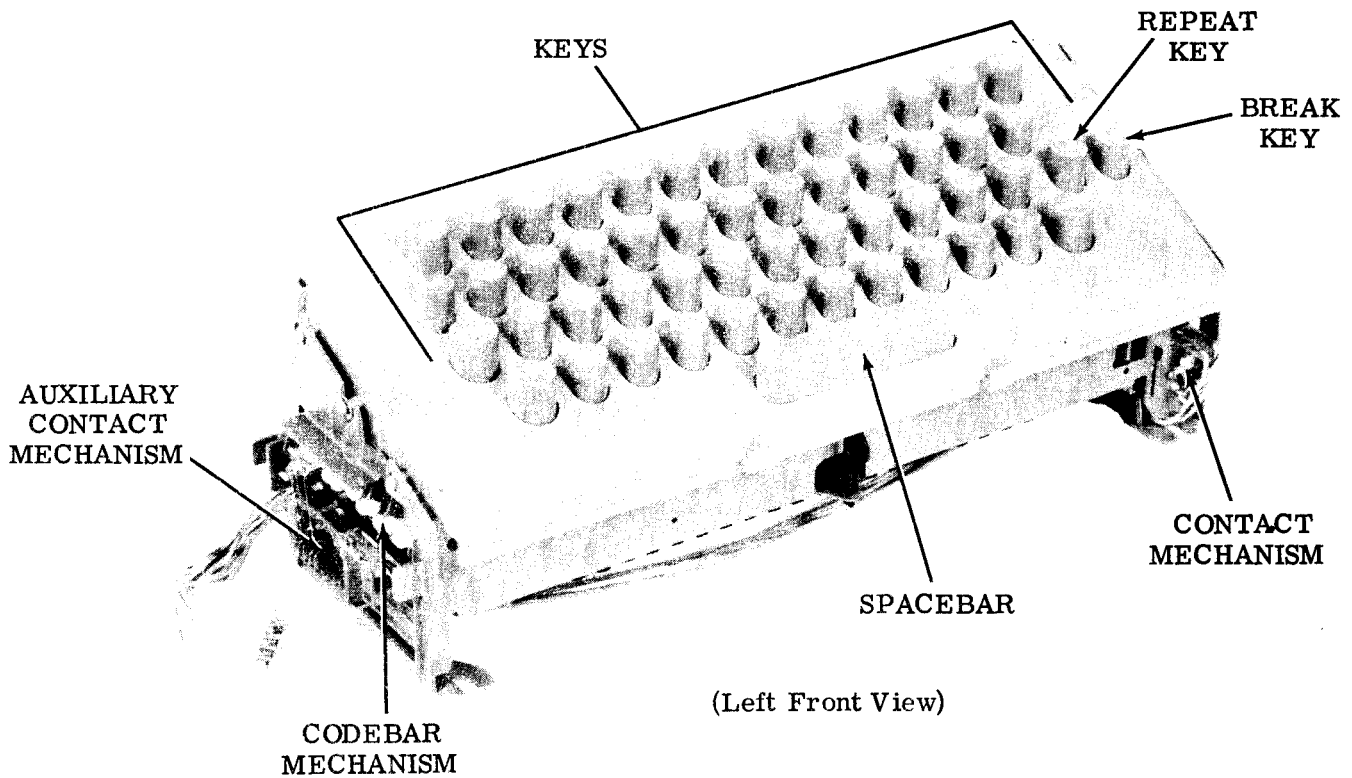
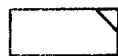
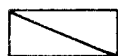

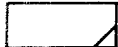

Figure 2 - Parity Keyboard

				b7	0	0	0	0	1	1	1	1
				b6	0	0	1	1	0	0	1	1
				b5	0	1	0	1	0	1	0	1
b4	b3	b2	b1									
0	0	0	0	NUL	DLE	SP	0	@	P			
0	0	0	1	SOH	DC1	!	1	A	Q			
0	0	1	0	STX	DC2	"	2	B	R			
0	0	1	1	ETX	DC3	#	3	C	S			
0	1	0	0	EOT	DC4	\$	4	D	T			
0	1	0	1	ENQ	NAK	%	5	E	U			
0	1	1	0	ACK	SYN	&	6	F	V			
0	1	1	1	BEL	ETB	/	7	G	W			
1	0	0	0	BS	CAN	(8	H	X			
1	0	0	1	HT	EM)	9	I	Y			
1	0	1	0	LF	SUB	*	:	J	Z			
1	0	1	1	VT	ESC Note 6	+	;	K	[
1	1	0	0	FF	FS	,	<	L	\		Note 2	
1	1	0	1	CR	GS	-	=	M]		Note 5	
1	1	1	0	SO	RS	.	>	N	^		Note 7	
1	1	1	1	SI	US	/	?	O	_			DEL

- NUL - Null
- SOH - Start of Heading
- STX - Start of Text
- ETX - End of Text
- EOT - End of Transmission
- ENQ - Enquiry
- ACK - Acknowledge
- BEL - Bell
- BS - Backspace
- HT - Horizontal Tabulation
- LF - Line Feed
- VT - Vertical Tabulation
- FF - Form Feed
- CR - Carriage Return
- SO - Shift Out
- SI - Shift In
- DLE - Data Link Escape
- DC - Device Control
- NAK - Negative Acknowledge
- SYN - Synchronous Idle
- ETB - End of Transmission Block
- CAN - Cancel
- EM - End of Medium
- SUB - Substitute
- ESC - Escape
- FS - File Separator
- GS - Group Separator
- RS - Record Separator
- US - Unit Separator
- SP - Space
- DEL - Delete

-  LOCKED OUT BY CONTROL
-  NOT APPLICABLE TO 33 EQUIPMENT
-  SHIFT CHARACTERS $\sqrt[5]{}$ $\sqrt[8]{}$
-  CONTROL CHARACTERS $^{-7}$ $\sqrt[8]{}$
-  LOCKED OUT BY SHIFT

Note 1: 1 = Mark, 0 = Space.

Note 2: Cannot be generated from keyboard.

Note 3: Blocks not indicating SHIFT or CTRL characters contain primary key characters.

Note 4: Filled-in corners or blocks indicate 8th pulse marking (in nonparity units, 8th pulse is always marking).

Note 5: This code can be generated on model 33 nonparity keyboards by depressing the ALT MODE key.

Note 6: The ESC control function may be generated by depressing the ESC key or by simultaneously depressing the K, SHIFT, and CTRL keys.

Note 7: One keyboard generates ESC for this code combination. ←

Figure 3 - 33 Application of ASCII

2.01 Dimensions and Weight (Approximate)

Height 5 inches
 Width 12-1/2 inches
 Depth 5 inches
 Weight 4-1/2 pounds

2.02 Electrical

Long loops 0.015 to 0.070 ampere,
 48 to 240 volts dc inductive
 Short loops 0.058 to 0.072 ampere,
 (local operation) 16 to 22 volts dc resistive

2.03 Transmission Code

Level 8

3. ASCII

3.01 The 33 keyboard operates according to ASCII. Figure 3 shows the 1968 version of the code used in 33 keyboards. The SHIFT and CONTROL characters, their associated key-top operation lockouts, and parity operation are also illustrated.

4. OUTLINE OF OPERATION

4.01 Transmission of messages is accomplished by an operator selectively depressing the keys and spacebar of the keyboard in the same manner as in typing. The downward movement of each key or the spacebar is translated by a codebar mechanism into a mechanical arrangement corresponding to the code combination representing the character on the keytop. The mechanical arrangements set up the code combinations in a set of keyboard contacts, and, by parallel output, the code combinations are transmitted to a distributor mechanism. A universal mechanism trips a distributor clutch, and a distributor mechanism then translates the parallel output from the keyboard contacts into corresponding start-stop signal for application to the transmission facilities.

5. DETAILED OPERATION

A. Codebar Mechanism

5.01 The codebar mechanism is illustrated in Figure 4.

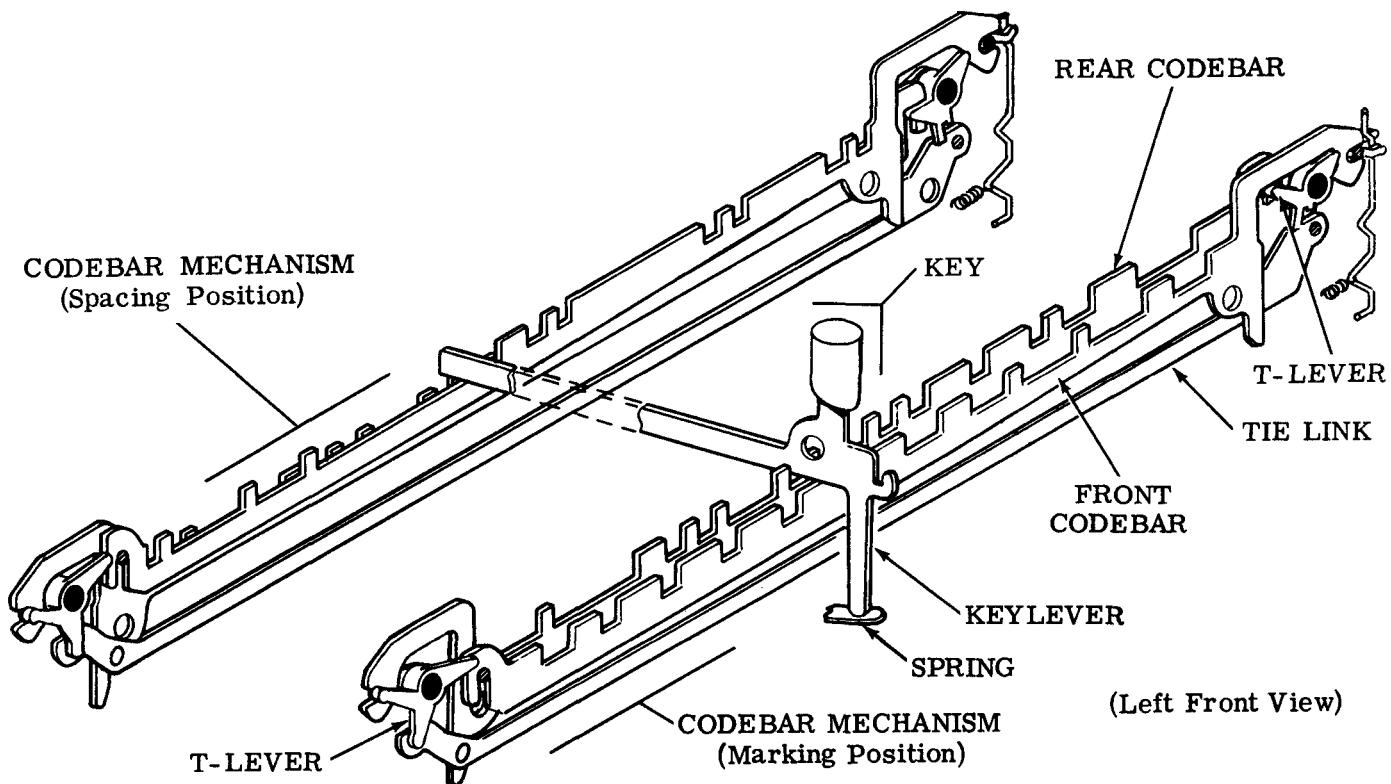

Figure 4 - Codebar Mechanism

5.02 For each level in the code there is a codebar mechanism which consists of a front codebar, a rear codebar, a tie link, and two T-levers. Thus in the 33 keyboard there are 8 pairs of codebars whose function is to set up 8 pairs of contacts in a coded arrangement representing the key depressed. The codebar mechanism also contains a shift mechanism (Figure 8) which consists of a front and rear codebar, a tie link, and two (three in parity keyboards) T-levers. Both the parity and nonparity keyboards contain a control blocking mechanism operated by the CTRL key. It consists of a tie link and two T-levers. The order in which the codebar mechanism is arranged varies, but the following may be considered typical. Thus from front to rear:

Nonparity Keyboard	UNIV, 1, SHIFT, 2, 3, 4, 5, 6, 7, CTRL
Parity Keyboard	UNIV, 1, 8, 2, 3, 4, 5, 6, 7, SHIFT, CTRL

5.03 The codebars have slots in their top edges which codes them so they are selectively depressed by the keys' keylevers. Each mechanism has a marking and a spacing position. In the marking position, the front codebar is down, the rear codebar is up, and the right T-lever is in the clockwise position. The spacing position is the opposite: front codebar up, rear codebar down, and right T-lever in counterclockwise position.

5.04 The two codebars in each mechanism are coded so that where one has a slot the other is solid. When a character key is depressed, it is returned to its up position by a leaf spring on the underside of the keyboard. However, the code combination set up in the codebars is retained until another key is depressed. When another key is depressed, only the mechanism whose code elements differ from those of the preceding combination are operated.

5.05 As an example assume that the letter E has been transmitted. The E code combination 1-3---78 remains in the codebar mechanisms. Now assume that the I (1--4--78) key is depressed. Its keylever encounters a slot in the rear codebar of the no. 1, 7, and 8 codebar mechanisms. Thus these mechanisms remain marking. In the case of the no. 2, 5, and 6 codebar mechanisms, the keylever encounters a slot in the front codebar, and they remain spacing. In the case of the no. 3 codebar mechanism, the keylever encounters the solid portion of the rear codebar and shifts it to its spacing position.

In a similar manner, the keylever encounters the solid portion of the front codebar of the no. 4 codebar mechanism and shifts it to the marking position.

5.06 Since each code combination is different and is locked in the codebar mechanisms, the complementary coding of the codebars serves as an interlock for the keylevers. When one keylever is depressed, another cannot be depressed because it will be blocked by the solid portion of one or more codebars.

B. Universal Codebar Mechanism

5.07 The universal codebar mechanism is illustrated in Figure 5.

5.08 As a keylever nears the bottom of its travel, it depresses a codebar which is part of the universal codebar mechanism. The codebar, in turn, causes associated T-levers to pivot and a tie link to move to the left. After some free movement, the tie link encounters a tab on a nonrepeat lever and pivots the latter to the left. The tab, in turn, pivots a latchlever which releases a universal lever. Under spring pressure, the universal lever moves up and lifts the nonrepeat lever so that its tab is moved from between the universal tie link and the latchlever. Under spring pressure, the latchlever and nonrepeat lever move back to the right to their unoperated position.

5.09 In its up position, the universal lever locks the right intelligence T-levers in the positions set up by the keylever, permits a contact bail to pivot to its down position and, through a trip linkage, trips the distributor clutch. Near the end of the distributor cycle, the trip linkage moves the universal lever back to its down position where it is latched by the latchlever.

5.10 Should the keylever remain depressed beyond the end of the distributor cycle, when the universal lever moves to its down position, the nonrepeat lever under spring tension moves down until it hangs up on the top of the universal tie link which is still in its left position. When the keylever is finally released, the tie link moves back to the right and permits the nonrepeat lever to move all the way down so that its tab is again between the tie link and the latchlever. The trip mechanism operates in this way to prevent the distributor clutch from being retripped when a keylever is held down.

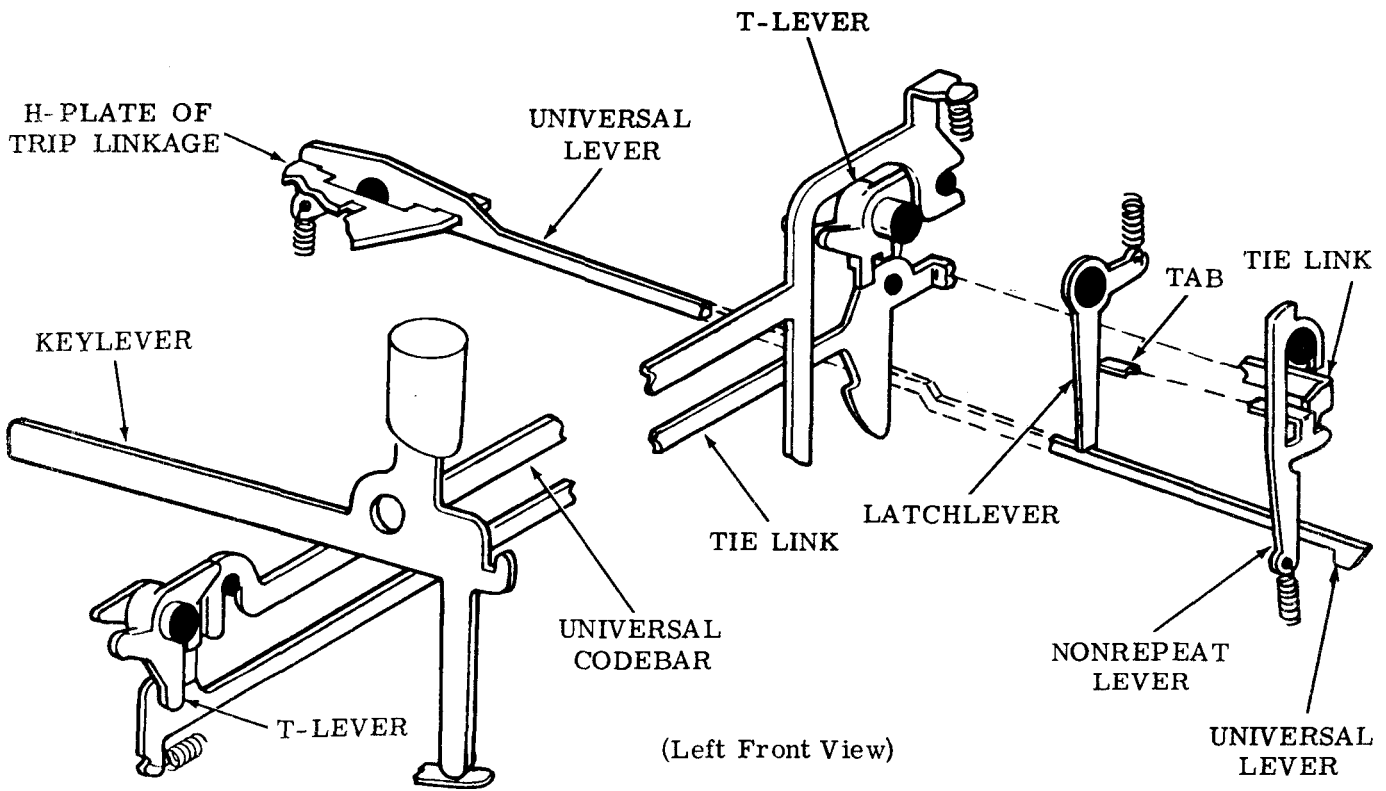

Figure 5 - Universal Codebar Mechanism

C. Keyboard Contact Mechanism

5.11 The keyboard contact mechanism is illustrated in Figure 6.

5.12 The codebar mechanisms set up the code combinations in a set of keyboard contacts. A contact wire is associated with each right T-lever, excluding the universal. In the stop condition of the keyboard, a contact bail is held in its up position by the universal lever. The contact bail holds the contact wires to the right, away from the T-levers.

5.13 When a keylever is depressed, a code combination is set up in the codebar mechanisms. The universal lever moves to its up position and permits the contact bail to pivot under spring tension to its down position. The contact wires associated with the T-levers that are in the marking (clockwise) position are permitted, under spring tension, to move to the left against a common terminal. Those associated with the T-levers that are in the spacing (counterclockwise) position are held to the right

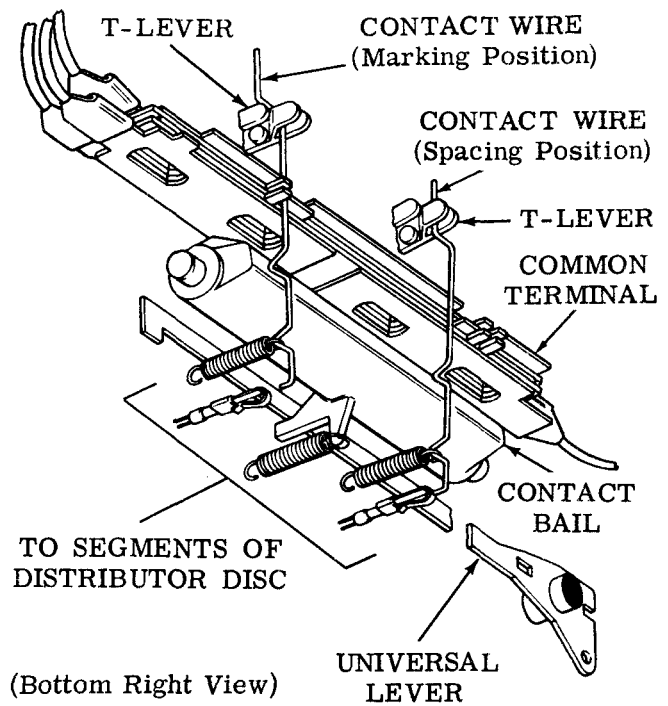

Figure 6 - Keyboard Contact Mechanism

away from the terminal. For example, if the I code combination (1--4--78) is set up in the code-bar mechanism, the no. 1, 4, 7, and 8 contact wires are against the common terminal. Similarly the no. 2, 3, 5, and 6 contact wires are away from the common terminal.

Note: When the universal lever is at the peak of its upward travel, it locks the T-levers in their assumed positions (Figure 7). This eliminates the possible loss of a marking or spacing pulse as a result of blocking T-levers repositioning during keyboard transmission.

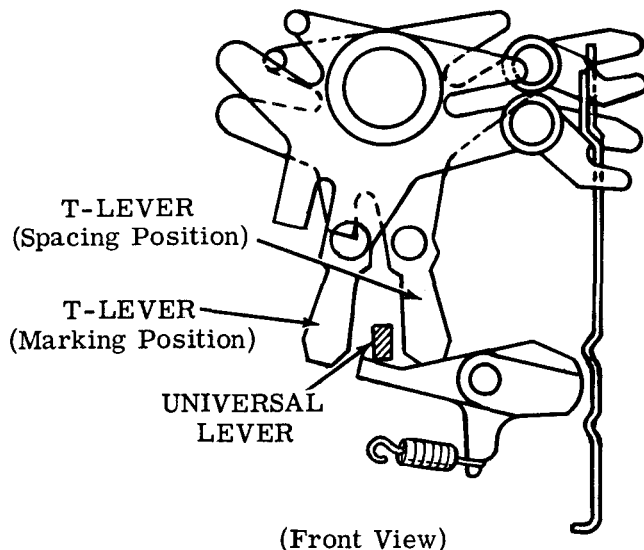

Figure 7 - T-Lever Positioning

5.14 The distributor mechanism converts these positions to start-stop signals. Near the end of the distributor cycle, the universal lever moves back to its down position and pivots the bail to its up position. The bail in turn cams the contact wires back to the right and holds them there in the stop position.

D. Line Break

5.15 When the BREAK key is depressed, it pivots a T-lever which opens the break contact. This action opens the signal line until the BREAK key is released.

E. Repeat

5.16 To repeat the transmission of a character, its keylever is held down along with the REPT keylever. The latter holds the nonrepeat

lever down where its tab remains between the tie link and the latchlever (Figure 5). The latchlever is held in its left position and does not latch the universal lever at the end of the cycle. The universal lever thus moves up and trips the distributor clutch causing the character to be retransmitted as long as the REPT key is depressed.

F. HERE IS

5.17 When the HERE IS key is depressed, its keylever pivots linkages in the typing unit which in turn activate the local answer-back.

G. Keyboard — Typing Unit Interface

5.18 The H-plate (Figure 5) serves as the mechanical interface between the keyboard and the typing unit.

5.19 After a key is depressed and the keyboard contacts are positioned, the universal lever moves to its up position. This upward movement is transferred by the H-plate to the distributor clutch linkage, to trip the distributor clutch. Near the end of the distributor cycle the trip linkage, through the H-plate, resets the universal lever back to its lower position.

H. Nonparity Operation

5.20 Figure 9 is a simplified schematic of the signal wiring for the nonparity keyboard.

5.21 Intelligence transmitted from the nonparity keyboard is that of the ASCII system. The keyboard contains two SHIFT keys and one CTRL (Control) key (Figure 8). The control key, utilizing a tie link and T-levers, operates a contact wire in the contact mechanism. The SHIFT key is used to generate the code combinations for printing characters appearing on the upper keytop (eg \$ above the 4). The CTRL key is used to generate the codes for the nonprinting control characters appearing on the upper keytops (eg EOT above the D). Simultaneous use of both CTRL and SHIFT keys allows access to special control functions, such as NULL. In every case, the SHIFT and/or CTRL keys must be held down while the appropriate character key is depressed.

5.22 The SHIFT key inverts the no. 5 code element on all 33 keyboards. If the element is normally marking, it makes it spacing; if the element is normally spacing, it makes it

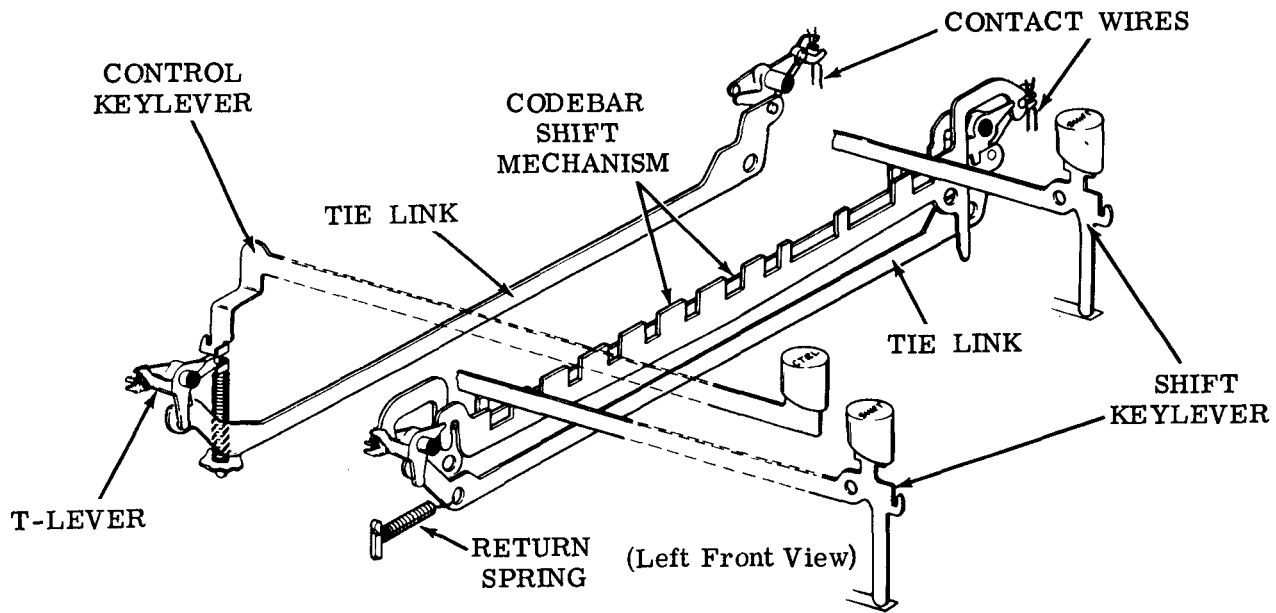
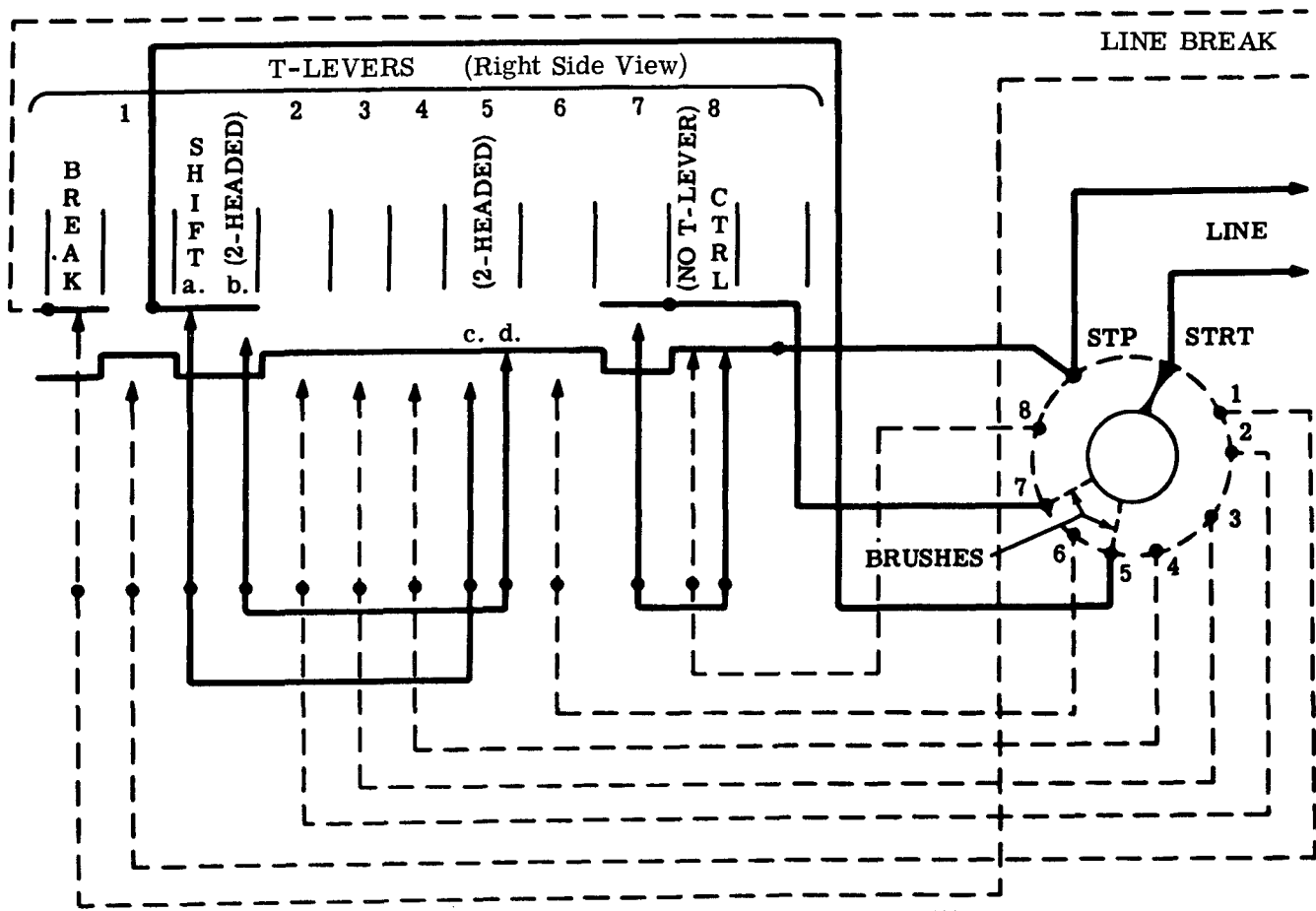

Figure 8 - SHIFT and CTRL Mechanisms — Nonparity Keyboard



Note: Intelligence contacts shown in spacing position.
Shift contacts shown in unoperated position.

Figure 9 - Contact Schematic — Nonparity Keyboard

marking. It does this by two 2-headed T-levers, one at the shift position, and one at the no. 5 position, each of which operates two contact wires, alternately opening one and closing the other. As shown in Figure 9, in the spacing condition, the "c" contact associated with the no. 5 T-lever is open, and the "d" contact is closed. In its unoperated position, the "a" contact associated with the SHIFT T-lever is closed, and the "b" contact is open. For example, if the "4" key alone is depressed, the code combination for "4" (--3-56-8) is set up in the keyboard contacts and subsequently transmitted. In this case, the 2-headed no. 5 T-lever holds the "c" contact closed and the "d" contact open, resulting in a marking no. 5 code element. (The signal path is through the stop distributor disc segment, the common terminal, the closed "c" contact, the closed "a" contact, the no. 5 distributor disc segment, the brushes, the inner distributor disc, and the start distributor disc segment, as shown in Figure 9.)

5.23 If the "4" key is depressed with the SHIFT key, the same condition is set up in the keyboard contacts, except that the 2-headed shift T-lever holds the "a" contact open and the "b" contact closed and thus opens the signal circuit. This results in the no. 5 code element being spacing rather than marking, and the code combination for "\$" (--3--6-8) being transmitted.

5.24 If the "N" key alone is depressed, the code combination for "N" (-234--78) is set by the codebars and subsequently transmitted to the line. In this case, the 2-headed no. 5 T-lever holds the "c" contact open and the "d" contact closed. On the other hand, if the "N" key is depressed with the SHIFT key, the same condition is set up in the keyboard contacts as before, except that the SHIFT key opens the "a" contact and closes the "b" contact and thus closes the signal circuit. This results in the no. 5 code element being marking rather than spacing and the code combination for ^ (-2345-78) being transmitted.

5.25 The CTRL key converts the no. 7 code element from marking to spacing. For example, if the "E" key alone is depressed, the "E" code combination (1-3---78) is set up in the keyboard contacts and subsequently transmitted. (The path of the current for the marking no. 7 code element is through the stop distributor disc segment, the common terminal, the closed control contact, the closed no. 7 contact, the no. 7

distributor disc segment, the brushes, the inner distributor disc, and the start distributor disc segment.) If the "E" key is held down with the CTRL key, the same condition as before is set up in the contacts, except that the control T-lever opens the control contact and thus breaks the signal circuit. This results in the no. 7 code element being spacing and the code combination for "ENQ" (1-3----8) being transmitted.

I. Parity Operation

5.26 The parity keyboard facilities are similar to those of the nonparity keyboard. The functional difference between parity and nonparity keyboards is in the control of the 8th level pulse.

5.27 These differences include the adding of a codebar mechanism to generate binary information for the eighth intelligence element. In addition, the SHIFT key operates an expanded shift codebar mechanism (Figure 10) which operates three 2-headed T-levers, two 2-headed T-levers control contact wires at the contact mechanism, and one 2-headed T-lever controls contact wires at an added auxiliary contact mechanism (Figure 10). Also, the CTRL key directly operates a 2-headed T-lever which controls contact wires at the auxiliary contact mechanism.

5.28 Figure 10 illustrates how the CTRL key acts to mechanically block all keys which normally have the no. 6 code element marking. When the CTRL key is depressed, a tab on the keylever engages the rear codebar of the no. 6 codebar mechanism and forces it into its spacing position. Simultaneously, the front codebar moves up, and the solid portions on it block the keylevers of all characters which normally have their no. 6 code element marking. This blocking action will prevent false characters from being transmitted.

Note: Keyboard lockout (keylever downward travel blocked by codebar mechanism) may occur if SHIFT or CTRL keytops are only partially depressed when the universal codebar mechanism is activated. To clear the lockout, again depress and release the SHIFT or CTRL keytops and, if necessary, also depress and release the specific primary keytop with which the lockout occurred.

5.29 The SHIFT key inverts the no. 5 and no. 8 code elements on the parity keyboard. If either element is normally marking, it makes it

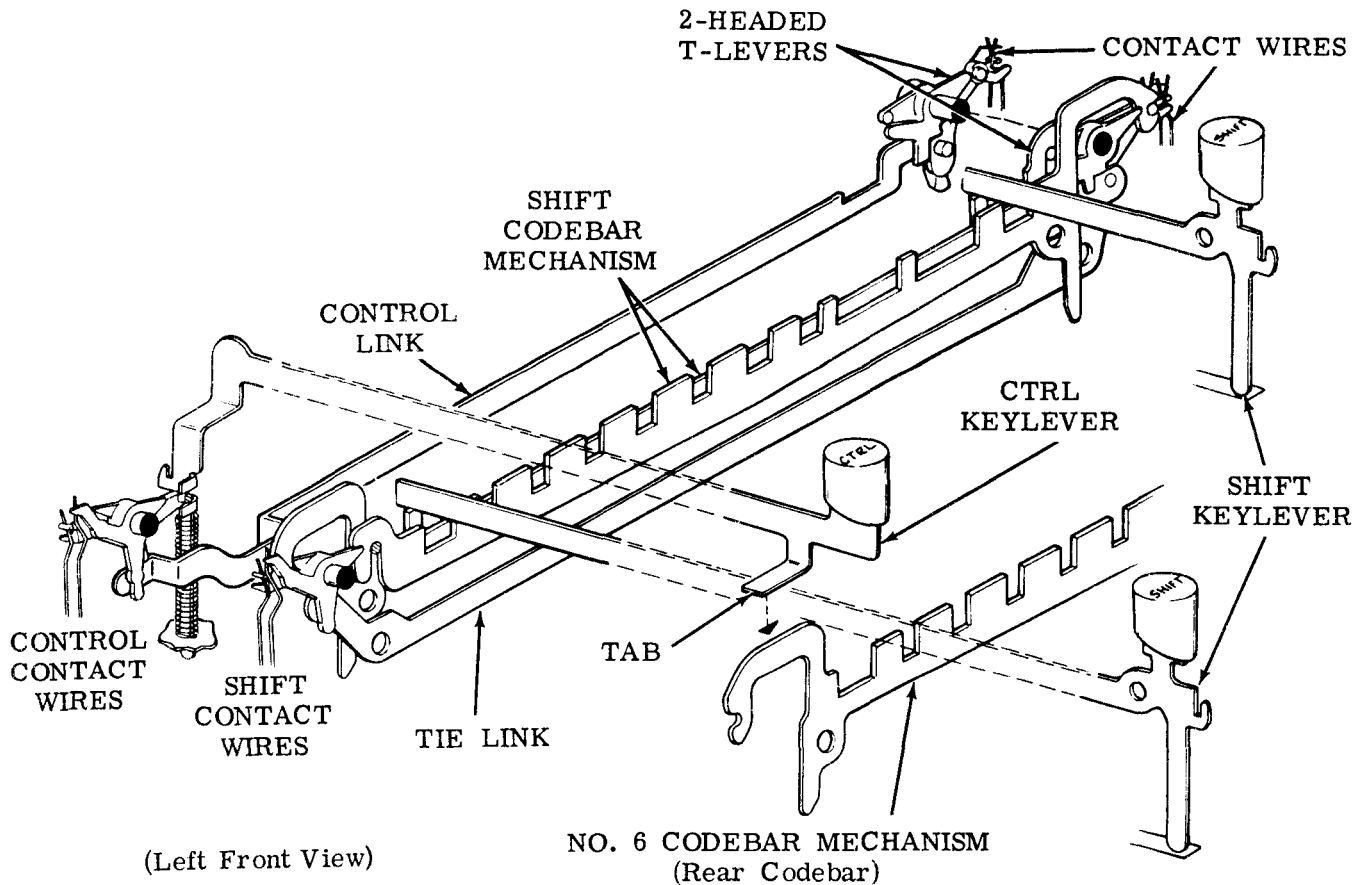
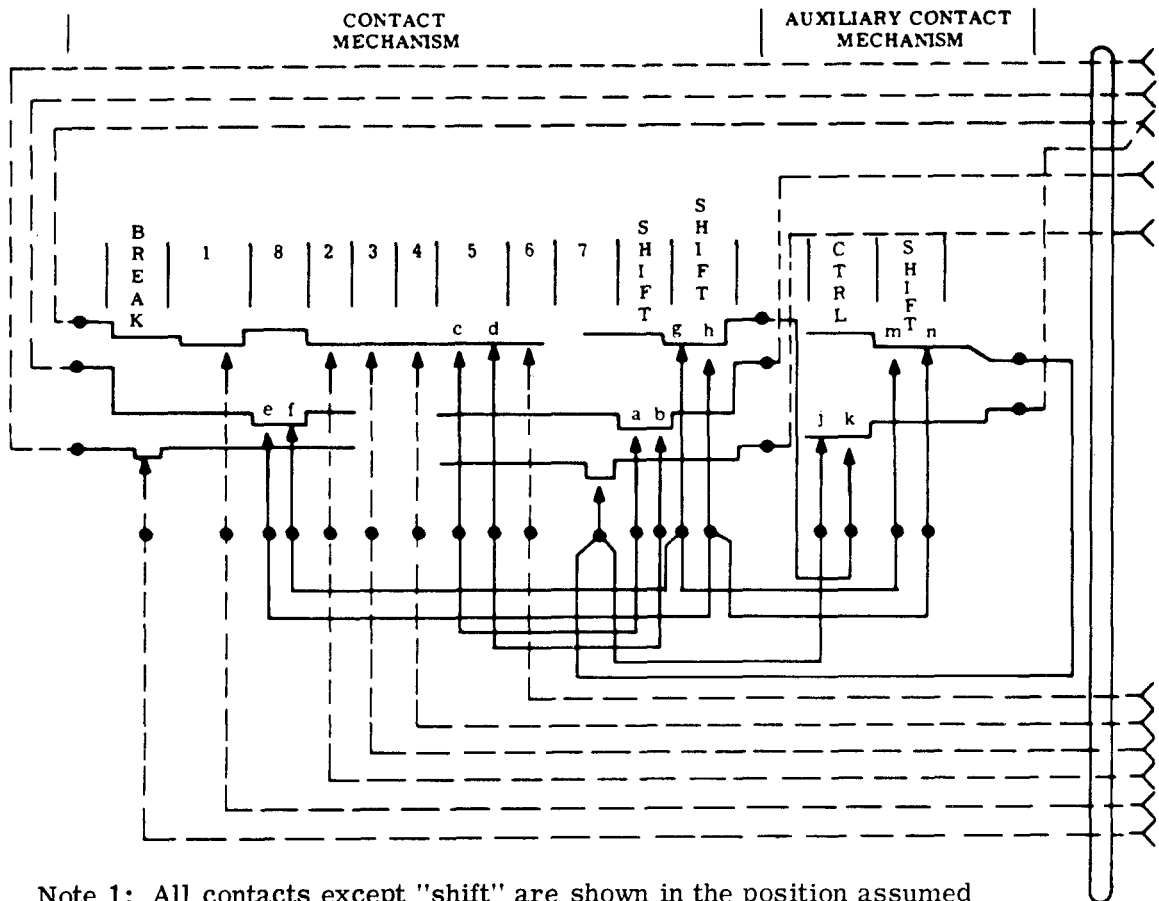

Figure 10 - SHIFT and CTRL Key Operation — Parity Keyboard

spacing; if either element is spacing, it makes it marking. This is accomplished by several 2-headed T-levers — one at the no. 5 position, two at the shift position on the contact mechanism, and one at the shift position on the auxiliary contact mechanism. Each 2-headed T-lever operates two contact wires, alternately opening one and closing the other. As shown in Figure 11 in the spacing condition, the "c" contact associated with the no. 5 T-lever and the "e" contact associated with the no. 8 T-lever are open, and the "d" and "f" contacts, respectively, are closed. In their unoperated positions, with the universal lever latched, the "b", "h", and "m" contacts associated with shift T-levers are open, while the "g" and "n" contacts are closed.

Note: The "a" contact is open on early design units equipped with the TP180043 shift marking contact wires and closed on late design units equipped with the TP186417 marking contact wires.

When the universal lever is tripped and the contact bail is pivoted, the "a" contact will be in the closed condition unless the SHIFT key is depressed, which will open the "a" contact and close the "b" contact. In addition, the "h" and "m" contacts will close and the "g" and "n" contacts will open. For example, if the "4" key alone is depressed, the code combination for "4" (--3-56-8) is set up in the keyboard contacts and subsequently transmitted. In this case, the 2-headed no. 5 T-lever holds the "c" contact closed and the "d" contact open, resulting in a marking no. 5 code element. The current path is from the connector, through the common terminal, the closed "c" contact, the closed "a" contact and terminal, and back to the connector. Since the no. 8 code element is to be marking, the 2-headed no. 8 T-lever holds the "e" contact closed and the "f" contact open. The current path is from the connector, through a terminal and the "e" contact, through the closed "n" contact and terminal, through the closed "j" contact and terminal, and back to the connector.



Note 1: All contacts except "shift" are shown in the position assumed when T-levers are in their counterclockwise position with universal lever latched.

Note 2: The "a" contact is open on early design units equipped with the TP180043 shift marking contact wires and closed on late design units equipped with the TP186417 marking contact wires.

Figure 11 - Contact Schematic — Parity Keyboard

5.30 If the "4" key is depressed with the SHIFT key, the same condition is set up in the keyboard contacts, except 2-headed T-levers hold the "a", "g", and "n" contacts open and the "b", "h", and "m" contacts closed. Thus, the current paths for the no. 5 and no. 8 code elements are open. This results in the no. 5 and no. 8 code elements being spacing rather than marking, and the code combination for \$ (--3--6--) is transmitted.

5.31 If the "N" key alone is depressed, the code combination for "N" (-234--7-) is set up by the codebars and subsequently transmitted to the line. In this case, 2-headed T-levers at the no. 5 and no. 8 positions,

respectively, hold the "c" and "e" contacts open and the "d" and "f" contacts closed. On the other hand, if the "N" key is depressed with the SHIFT key, the same condition is set up in the keyboard contacts as before, except that T-levers associated with the shift position open the "a", "g", and "n" contacts and close the "b", "h", and "m" contacts. Thus current paths for the no. 5 and no. 8 code elements are closed. This results in the no. 5 and no. 8 code elements being marking rather than spacing, and the code combination for ^ (-2345-78) is transmitted.

5.32 The CTRL key converts the no. 7 code elements from marking to spacing and inverts the no. 8 code element. When the CTRL

key is operated, the no. 7 code element will always be spacing. Also, the no. 8 code element will be made spacing if it is normally marking; it will be made marking if it is normally spacing. For example, if the "D" key alone is depressed, the code combination (--3---7-) is set up in the keyboard contacts and subsequently transmitted. The current path for the marking no. 7 code element is from the connector, through the terminal and the closed no. 7 contact, through the closed "j" contact and terminal, and to the connector. Since the no. 8 code element is to be spacing, the 2-headed no. 8 T-lever holds the "e" contact open and the "f" contact closed, and there is no current path. If the "D" key is held down with the CTRL key, the same condition as before is setup in the contacts, except the 2-headed control T-lever opens the "j" contact and closes the "k" contact. This breaks the current path through the no. 7 contact, but closes the path through the "f" contact of the 2-headed no. 8 T-lever. The current path for the no. 8 code element is from the connector, through the terminal and closed "f" contact, through the closed "g" contact and terminal, through the closed "k" contact and terminal, and to the connector. This operation results in the no. 7 code element spacing and the no. 8 code element being marking. Thus, the code combination for "EOT" (--3----8) is transmitted.

6. KEYBOARDS FOR 3300 SERIES CODED SETS AND COMPUTER INPUT/OUTPUT SETS

KEYBOARDS FOR 3300 SERIES CODED SETS

6.01 A typical keyboard arrangement for the 3300 Series Coded Sets is shown in Figure 12. Keyboards for these sets are shipped

from the factory with even parity installed. The customer may:

- (a) Retain even parity, or
- (b) Wire the keyboard for the 8th bit always marking, or
- (c) Wire the keyboard for the 8th bit always spacing.

6.02 These wiring options are implemented by connecting wires to terminals at the right front of the keyboard, and at the left contact block. The options and the corresponding wiring are shown in Keyboard Wiring Options Table.

KEYBOARD WIRING OPTIONS TABLE

OPTION	LEAD 1	LEAD 2	LEAD 3	LEAD 4
Even parity	ON	OFF	OFF	ON
8th bit always mark	OFF	ON	ON	ON
8th bit always space	Either LEAD 1 or LEAD 2 ON or both OFF.		ON or OFF	OFF

Note: Refer to 9334WD for identification of leads.

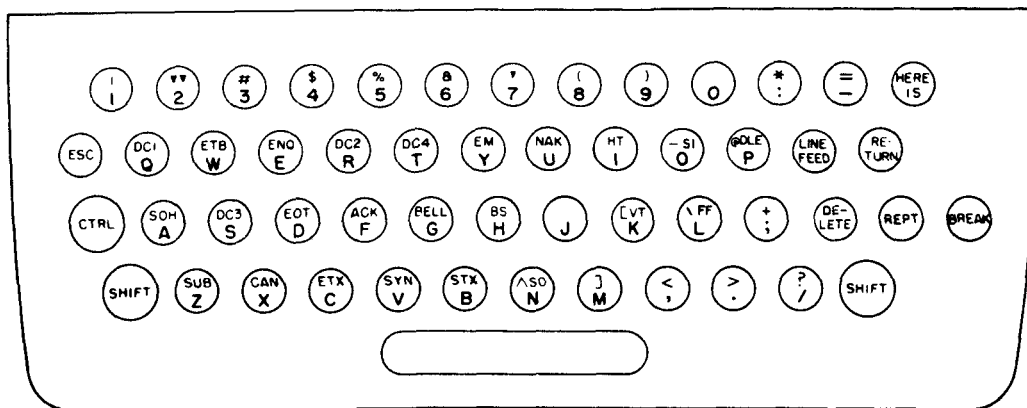

Figure 12 - Typical Keyboard Arrangement for 3300 Series Coded Sets

KEYBOARDS FOR COMPUTER INPUT/OUTPUT SETS

6.03 The keyboard for Computer I/O Sets is an even parity keyboard similar to the keyboard described in Part 5 except that a lock mechanism is added. The keyboard arrangement is shown in Figure 13. Refer to Part 5 for details on the operation of the various mechanisms of the keyboard. Subsequent paragraphs describe the locking mechanism.

6.04 The function of the locking mechanism is to block the universal lever in its latched position, thus preventing tripping the distributor clutch in the typing unit (Figure 14).

6.05 The locking mechanism consists of a solenoid, which, thru a cam shaft assembly, operates a trip cam which blocks the universal lever, preventing it from being tripped. When the solenoid is energized, the solenoid plunger is pulled causing the cam shaft assembly to rotate and the trip cam to move into position to block the universal lever.

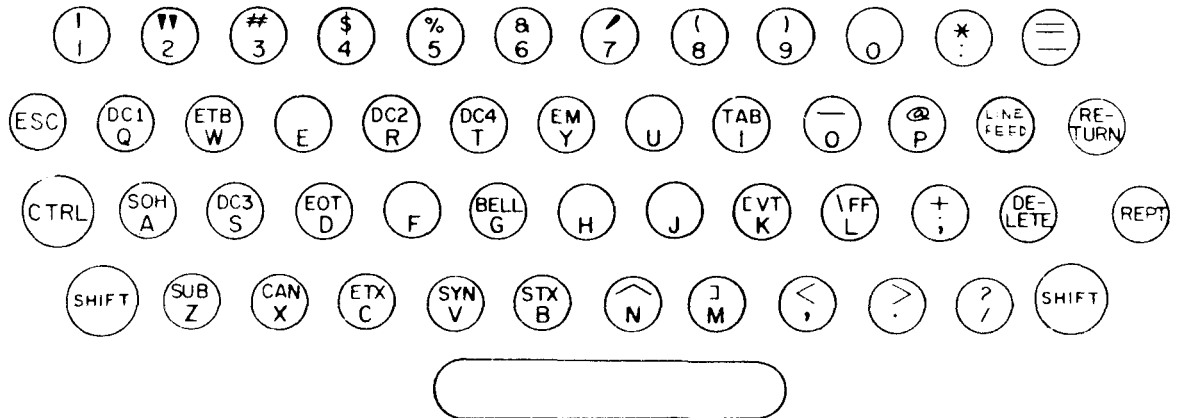

Figure 13 - Keyboard Arrangement for Computer I/O Sets

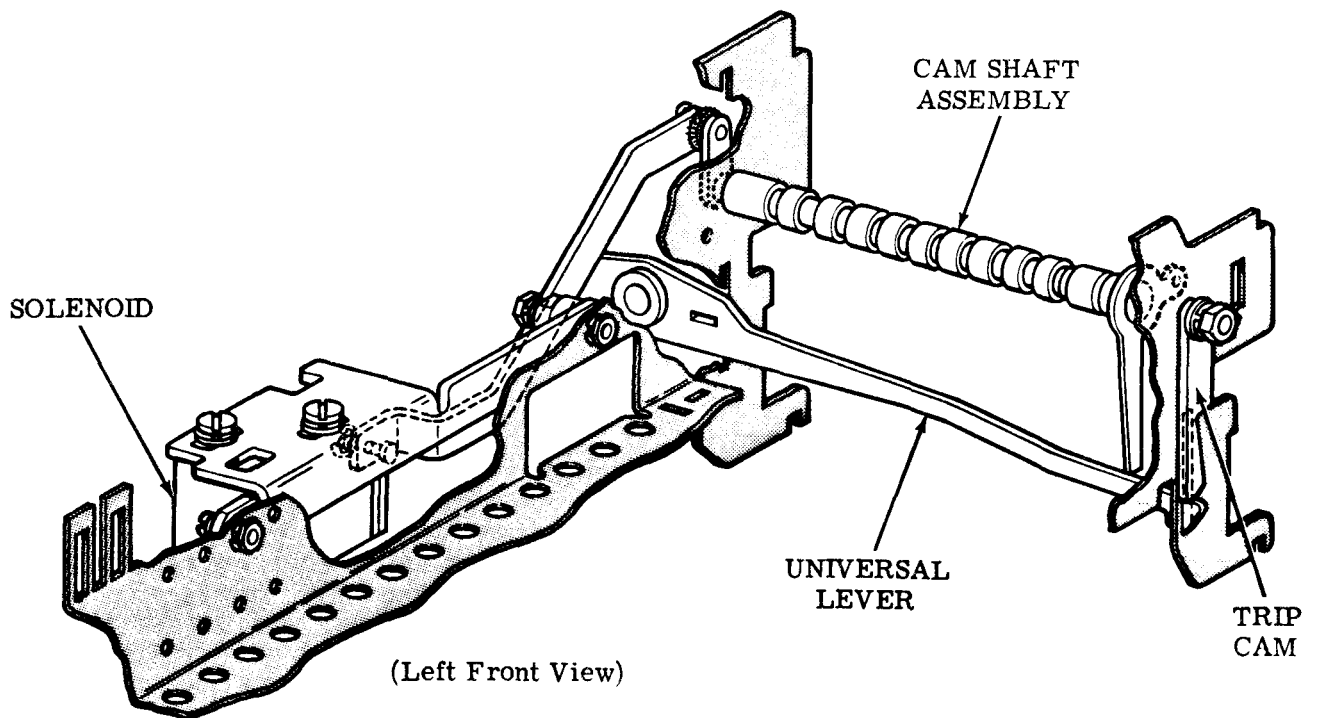
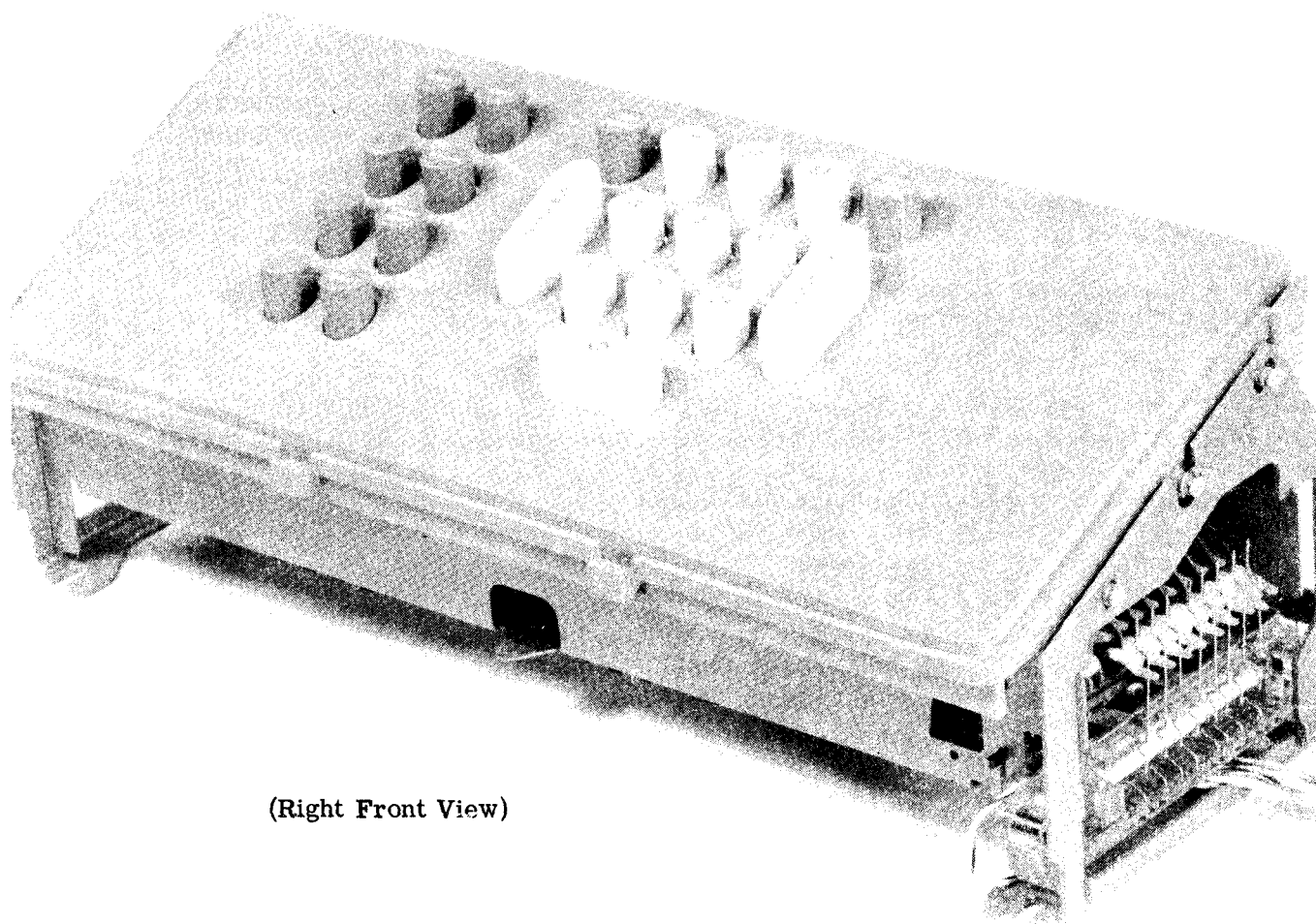

Figure 14 - Keyboard Locking Mechanism for Computer I/O Sets



(Right Front View)

Figure 15 - Numeric Keyboard

bly to rotate. Rotation of the cam assembly causes the trip cam to drive the universal lever (which is in the latched, down, position) further down and blocks it.

6.06 This lock mechanism operates only when the universal lever is latched (down position). If the set is turned off and the keyboard is tripped, the lock mechanism will not operate.

6.07 This mechanism locks the entire keyboard, with the exception of the HERE IS key which trips the answer-back mechanism directly.

7. NUMERIC KEYBOARD

7.01 The numeric keyboard is shown in Figure 15. Like the alphanumeric keyboard, the numeric keyboard utilizes the eight level ASCII at 100 words per minute. In some appli-

cations the numeric keyboard, when used as part of an ASR set, is used for off-line tape perforations of basically numeric information, for use in later transmission.

7.02 Numerics transmitted are 0 through 9; nonprint functions utilized are EOT, SPACE, RUBOUT, RETURN, and LINE FEED. A repeat key is also located on the keyboard. The HERE IS keylever hole has been plugged for optional field installation. On some numeric keyboards, there is a plugged keylever hole for optional installation of the FORM-FEED keylever, and the codebars are coded for FORM-FEED. Depending on the keyboard, it contains FS, GS, RS, and US keys or variations of these keys.

7.03 The operation of the numeric keyboard is similar to the alphanumeric keyboard as described in Part 5.

33 KEYBOARD
 LUBRICATION

CONTENTS	PAGE
1. GENERAL	1
2. BASIC UNIT	2
Auxiliary contact block	4
Codebar mechanism	5
Contact block	4
CTRL keylever	4
HERE IS, BREAK, and REPT keylevers	3
Keyboard	2
Keylevers	3
Latchlever hooks	5
Numeric keyboard (cover removed) . .	6
Numeric keylevers	7
Reset bail	5
Spacebar	3
SPACE, BLOCK, and O keylevers . .	7
Universal lever	6
3. KEYBOARD FOR COMPUTER I/O SET	8 ←
Locking Mechanism	8 ←

1.04 Lubricate the keyboard before placing it into service or prior to storage. After a short period of service, relubricate it to make sure no areas have been missed. Thereafter, lubricate the keyboard at regular intervals as indicated:

<u>Operating Speed</u> (Words per Minute)	<u>Lubrication</u> <u>Interval</u>
100	500 hours* or 6 months**

*Station set operating hours.
 **Whichever comes first.

1.05 The textual instructions that accompany each line drawing consist of abbreviated directions, specific lubrication points, and parts affected. The meanings of the abbreviated directions (symbols) are given below:

<u>Symbol</u>	<u>Meaning</u>
D	Keep dry — no lubricant permitted.
O	Oil (KS7470).
G	Apply thin coat of grease (KS7471).

1.06 References to left, right, front, or rear, etc, consider the keyboard to be viewed from a position where the spacebar faces up and the contact mechanism is located to the viewer's right.

1. GENERAL

1.01 This section provides lubrication requirements for the 33 keyboard. It is reissued to provide lubrication instructions for the locking mechanism of keyboards for computer input/output (I/O) sets. Marginal arrows indicate the addition.

1.02 The general lubrication areas are illustrated by photographs. The specific points to receive lubricant are indicated on line drawings with appropriate textual instructions. The line drawings and textual instructions follow a photograph and are keyed to the photograph by paragraph numbers.

1.03 Thoroughly lubricate the keyboard, but avoid overlubrication that might permit the lubricant to drip or be thrown onto adjacent parts.

CAUTION: DO NOT USE ALCOHOL, MINERAL SPIRITS, OR OTHER SOLVENTS TO CLEAN PLASTIC PARTS OR PARTS WITH PROTECTIVE-DECORATIVE FINISHES. NORMALLY, A SOFT, DRY CLOTH SHOULD BE USED TO REMOVE DUST, OIL, GREASE, OR OTHERWISE CLEAN PARTS OR SUBASSEMBLIES. IF NECESSARY, A SOFT CLOTH

DAMPENED WITH SOAP OR MILD DETERGENT MAY BE USED. RINSE WITH A SOFT, DAMP CLOTH AND BUFF WITH A SOFT, DRY CLOTH.

1.07 Materials needed for lubrication are listed in Section 570-005-800TC.

1.08 Disassembly and reassembly instructions are given in Section 574-121-702TC.

CAUTION: REMOVE ALL ELECTRICAL POWER FROM UNIT BEFORE LUBRICATION OR DISASSEMBLY.

2. BASIC UNIT

2.01 Keyboard

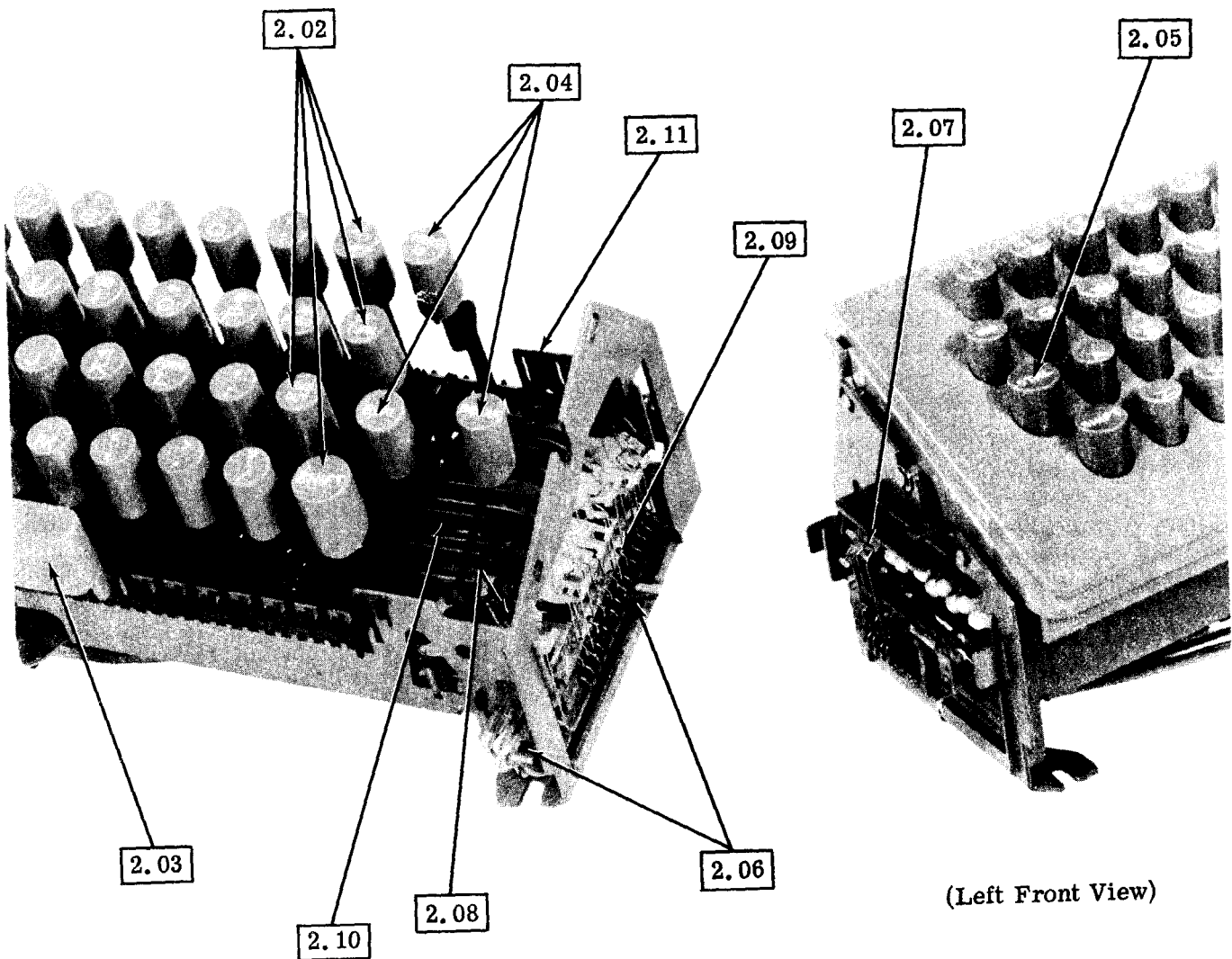

(Right Front View
Cover Removed)

(Left Front View)

2.02 Keylevers

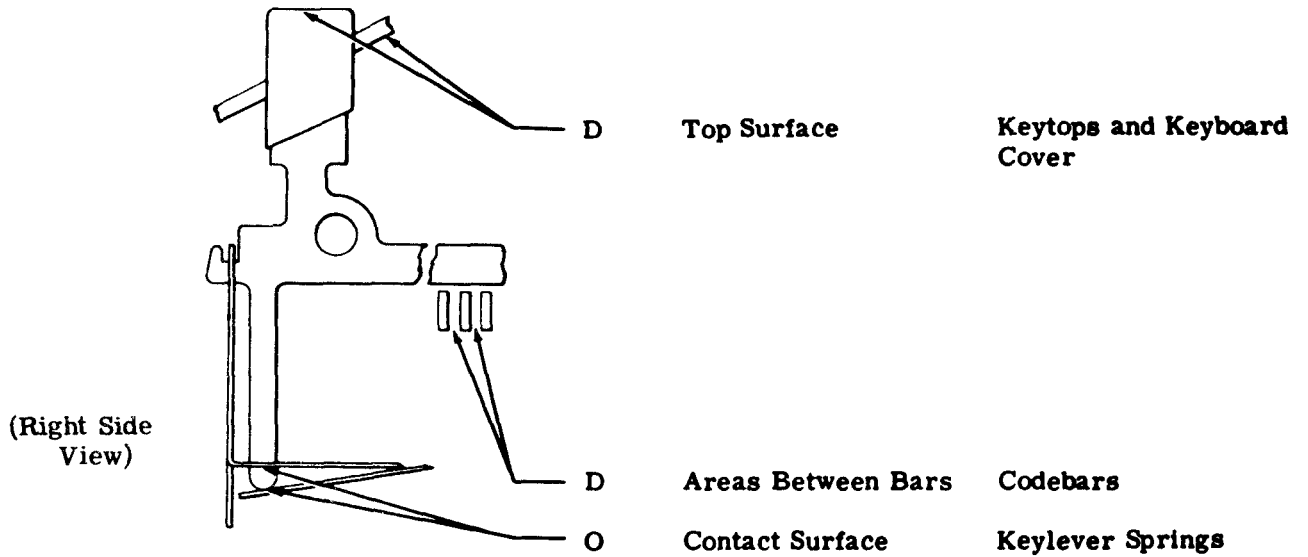

2.03 Spacebar

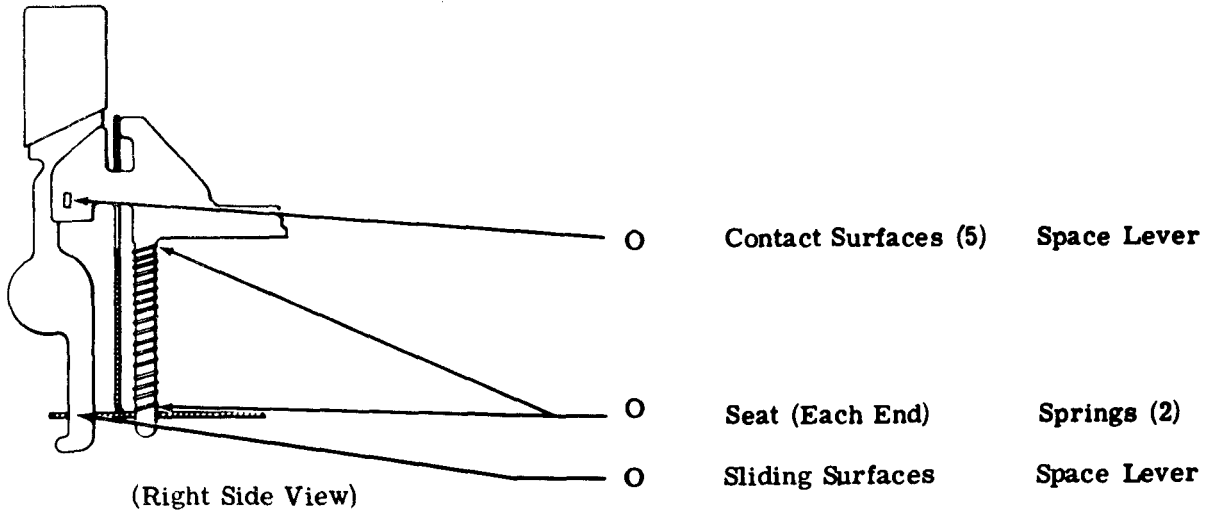

2.04 HERE IS, BREAK, and REPT Keylevers

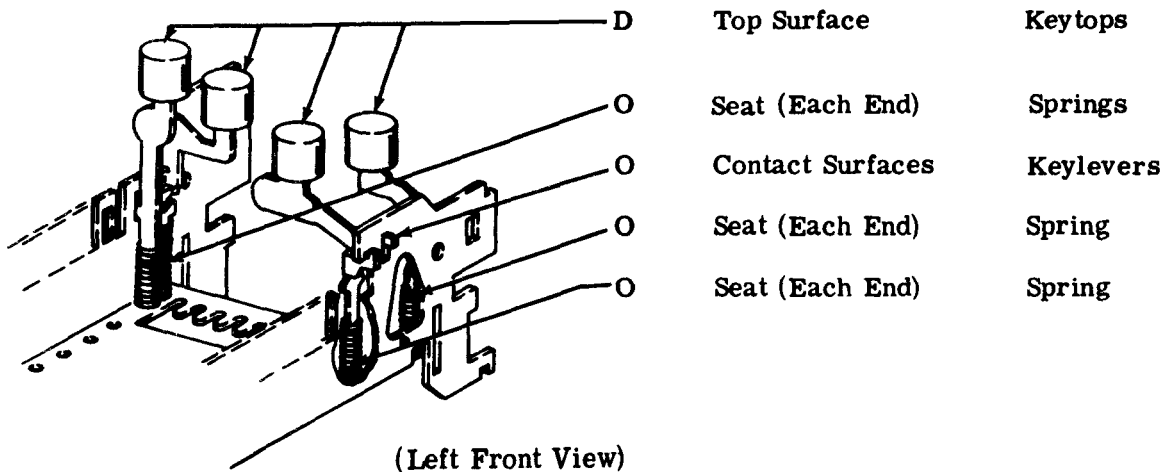

2.05 CTRL Keylever

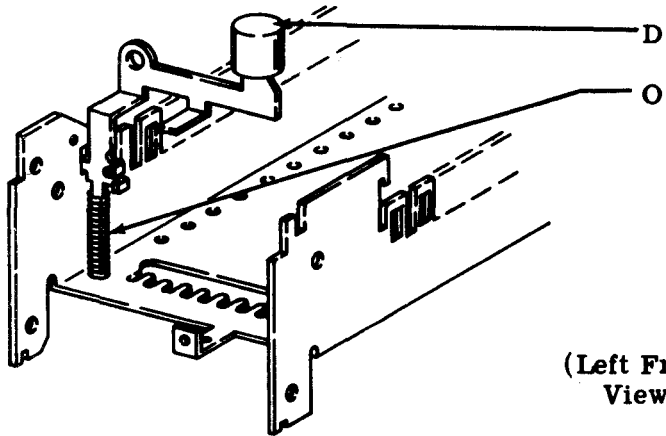

D	Top Surface	Keytop
O	Seat (Each End)	Spring

(Left Front View)

2.06 Contact Block

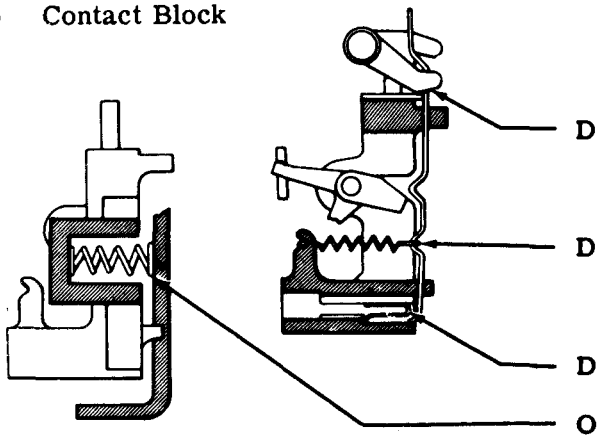

D	Contact Surface	Contact Wires
D	Springs	Contact Wires
D	Contact Surface	Contact Wires
O	Seat	Springs (2)

(Front Views)

CAUTION: DO NOT CLEAN THE KEYBOARD CONTACT BLOCK WITH ALCOHOL, MINERAL SPIRITS, OR OTHER SOLVENTS.

2.07 Auxiliary Contact Block

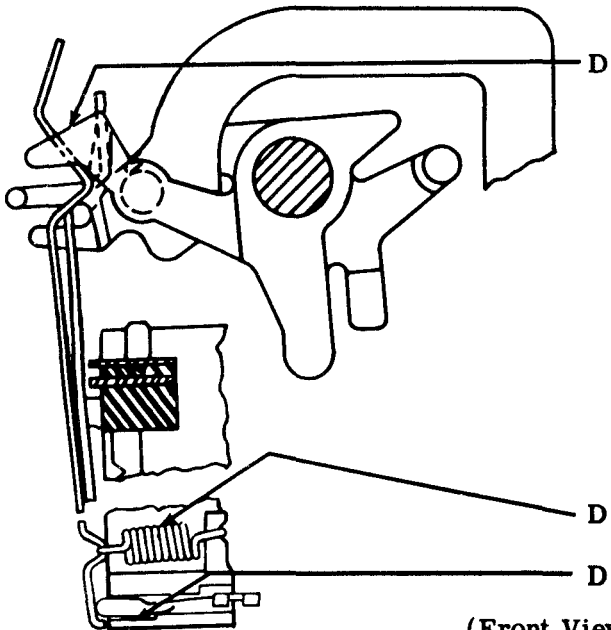

D	Contact Surfaces	Contact Wires
D	Springs	Contact Wires
D	Contact Surface	Contact Wires

(Front View)

2.08 Latchlever Hooks

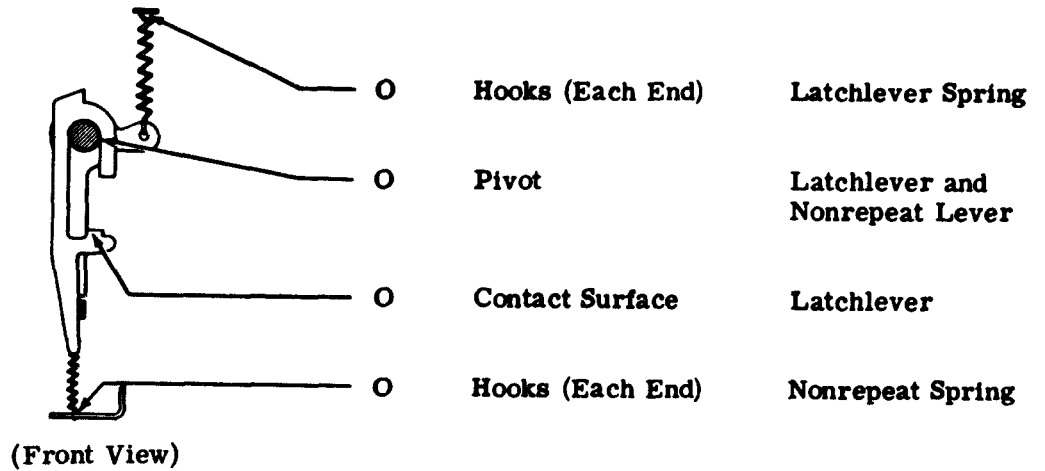

2.09 Reset Bail

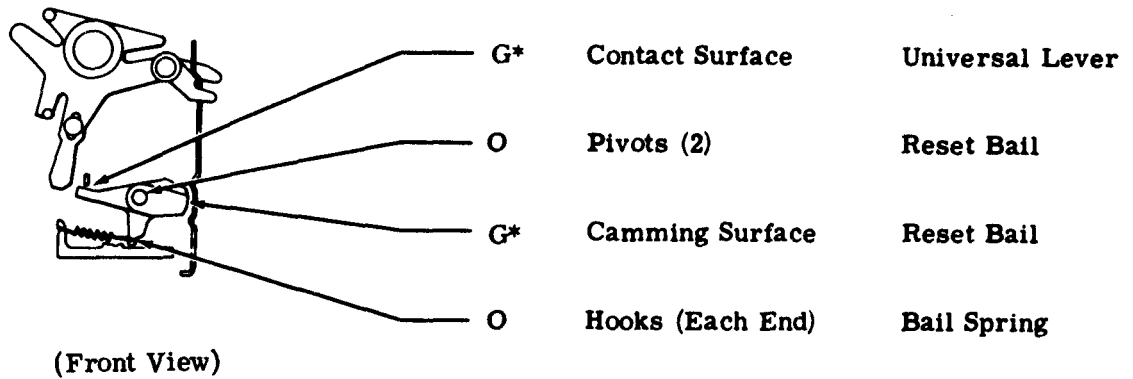

*At 1500 hour lubrication intervals, apply a coat of thoroughly mixed 50 percent KS7470 oil and 50 percent KS7471 grease.

2.10 Codebar Mechanism

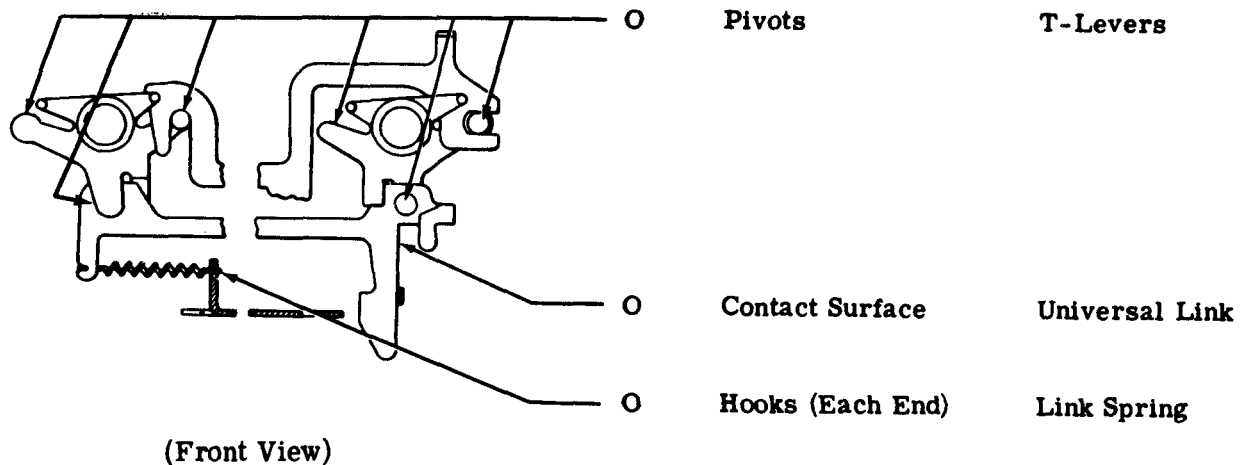

2.11 Universal Lever

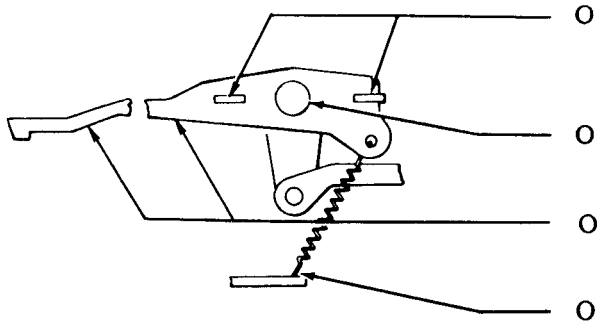

- O Engaging Tabs H-Lever
- O Pivot Universal Lever
- O Engaging Surfaces Universal Lever
- O Hooks (Each End) Spring

(Right Side View)

2.12 Numeric Keyboard (Cover Removed)

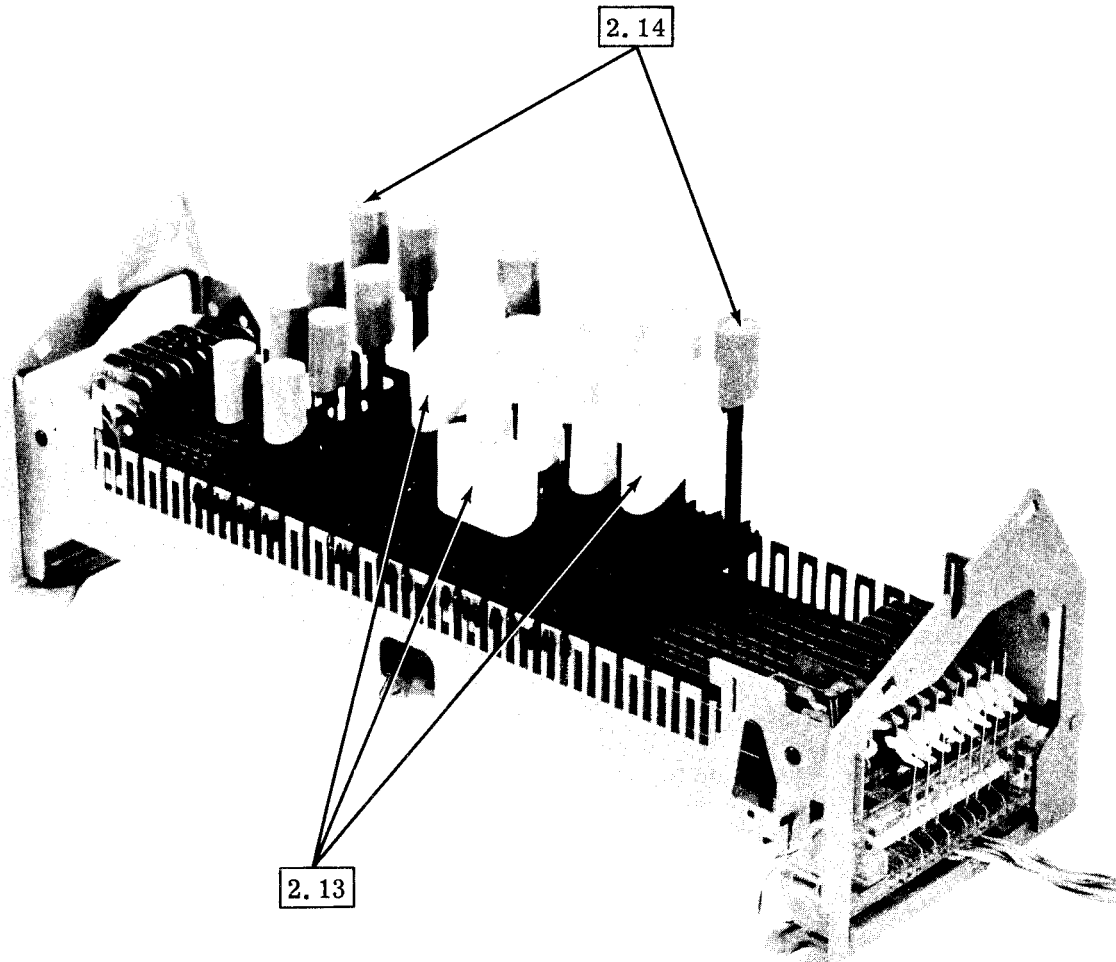

(Right Front View)

2.13 SPACE, BLOCK, and O Keylevers

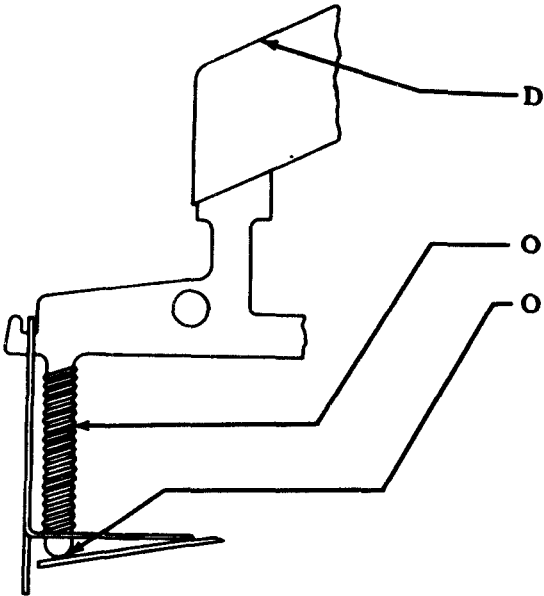

- D Top Surface Keytop
- O Seat (Each End) Spring
- O Contact Surface Keylever Springs

(Right Side View)

2.14 Numeric Keylevers

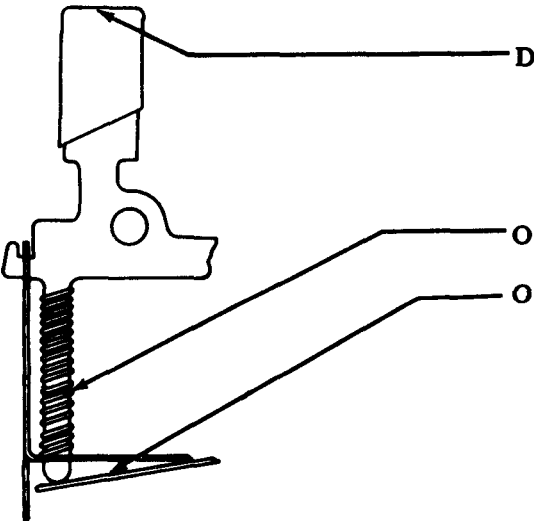

- D Top Surface Keytops
- O Seat (Each End) Spring
- O Contact Surface Keylever Springs

(Right Side View)

3. KEYBOARD FOR COMPUTER I/O SET

3.01 Locking Mechanism

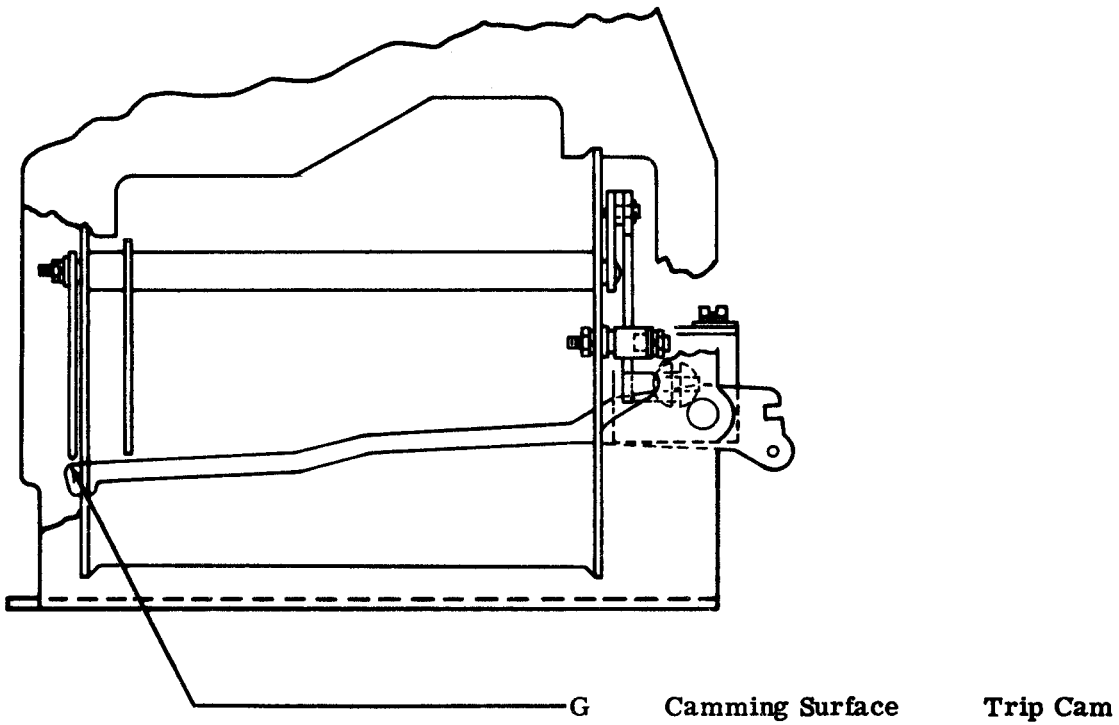
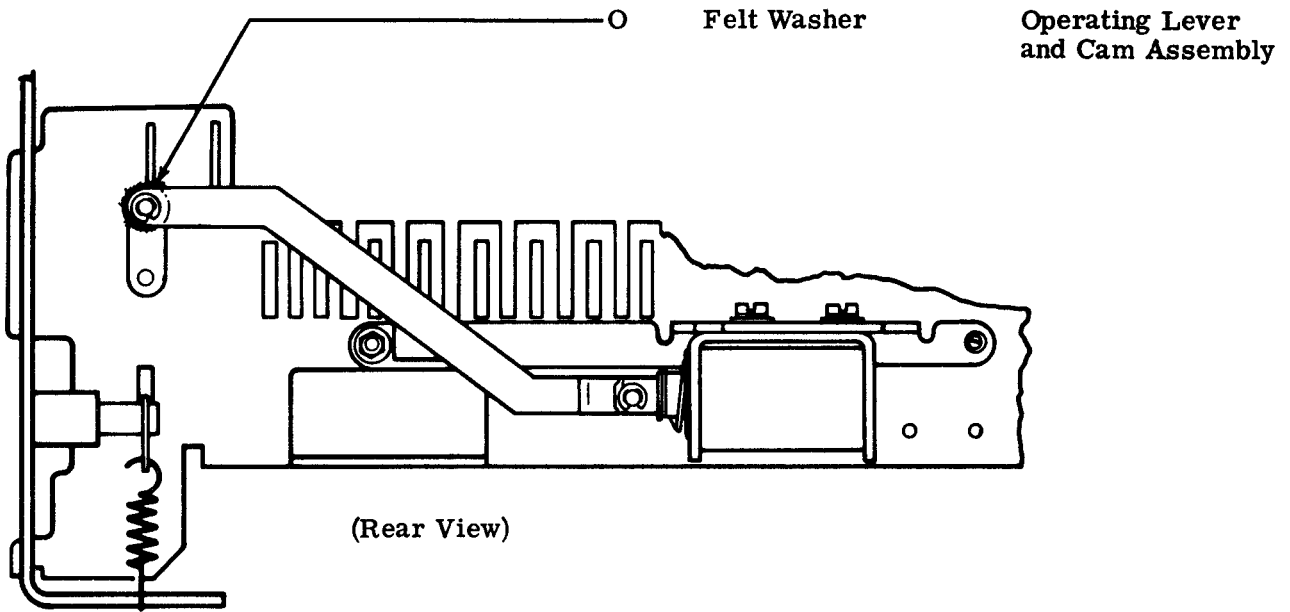

33 KEYBOARD

DISASSEMBLY AND REASSEMBLY

CONTENTS	PAGE
1. GENERAL	1
2. DISASSEMBLY AND REASSEMBLY ..	1
KEYLEVER COVER	1
KEYLEVER.	2
SPACEBAR MECHANISM.	3
CODEBAR.	4
KEYBOARD CONTACT MECHANISM	4
AUXILIARY CONTACT MECHANISM	4
T-LEVER SHAFT.	4
3. DISASSEMBLY AND REASSEMBLY OF LOCKING MECHANISM IN KEYBOARDS FOR INPUT/OUTPUT SETS	4

help in determining their location, the numbers of the parts are given in the instructions.

CAUTION: BEFORE BEGINNING DISASSEMBLY, REMOVE CONNECTORS FROM EXTERNAL RECEPTACLES (POWER SOURCE, DATA SET, ETC).

1.04 When self-tapping screws are used to mount mechanisms onto castings, do not remove the self-tapping screws. Merely loosen them enough to remove the mechanisms unless specifically instructed otherwise.

1.05 Retaining rings are made of spring steel and have a tendency to release suddenly. To avoid loss of these rings when removing them, proceed as follows:

- (a) Hold retaining ring to prevent its rotating.
- (b) Place blade of screwdriver in one of ring's slots and rotate screwdriver to increase diameter.
- (c) Ring will come off easily in fingers without flying.

1.06 All tools used to remove the mechanisms referred to in this section can be found in the 570-005-800TC standard tool section.

1.07 All damaged, worn, or distorted parts should be replaced if encountered in the disassembly and reassembly procedures.

2. DISASSEMBLY AND REASSEMBLY

Note: For information concerning the proper procedure to remove the keyboard assemblies from the set, refer to appropriate disassembly and reassembly set section.

1. GENERAL

1.01 This section provides disassembly and reassembly for the 33 type keyboard. It is reissued to incorporate disassembly and reassembly information for the locking mechanism in keyboards for Computer Input/Output (I/O) Sets. Marginal arrows are used to indicate additions and changes.

1.02 References to left, right, front, rear, etc, consider the keyboard to be viewed from a position where the spacebar faces up and the contact mechanism is located to the viewer's right.

1.03 Disassembly, as outlined in this section, covers the procedure for removing the principle subassemblies which make up the unit. If further disassembly is required, refer to the appropriate illustrated parts section which shows detailed arrangements of parts. Where it will

KEYBOARD COVER

2.01 To remove the keyboard cover (Figure 2), proceed as follows.

- (a) Remove TP119652 retaining ring and TP41663 flat washer from the left side of the keyboard cover, and rotate the left side bracket away.
- (b) Hold the right side bracket firmly in place against the two TP180031 compression springs of keyboard contact mechanism, and remove the TP119652 retaining ring and TP41663 flat washer from the right side of the keyboard cover.
- (c) Continue to hold the right side bracket firmly in place, and disengage the keyboard cover from the right side bracket by moving it up and to the left. Lift the keyboard cover off the keys.

Note: With the keyboard cover removed, the right side bracket may be pushed un-

expectedly from its assembled position, due to the spring load of two compression springs. If this happens, certain parts may prematurely fall off. To prevent this, always keep the right side bracket firmly against the two compression springs of the keyboard contact mechanism, i e, either hold the right side bracket in place by hand or place it firmly against a fixed vertical surface.

- (d) To replace the keyboard cover, reverse the procedure used to remove it.

KEYLEVER

2.02 To remove any keylever (Figure 1), proceed as follows.

- (a) Depress the front end of the TP182240 (early design) or TP185766 universal lever, or the TP186253 (late design) universal lever.

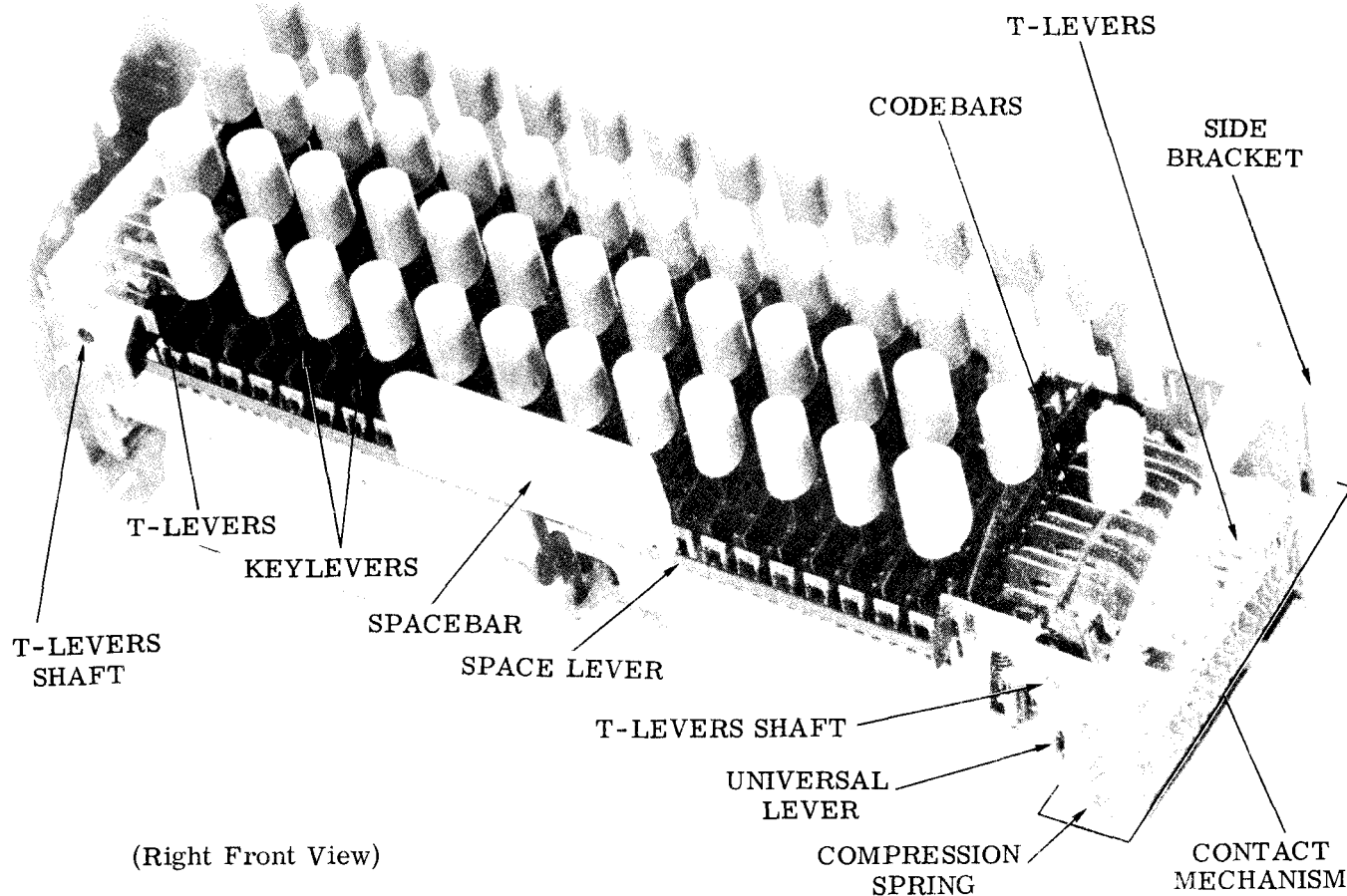

Figure 1 - Keyboard (Cover Removed)

- (b) Depress keylever and disengage it from front or rear guide slot.
- (c) Lift keylever out of keyboard frame.
- (d) To replace any keylever, reverse procedure used to remove it.

Note: Certain levers have compression springs on their lower stems. Make sure that the springs are properly replaced during reassembly.

SPACEBAR MECHANISM

- 2.03 To remove spacebar mechanism (Figure 1), proceed as follows.
 - (a) Remove the TP180057 spacebar with the attached TP180054 keylever.
 - (b) Bow the TP180056 space lever and disengage it from the two TP180055 space keylevers.

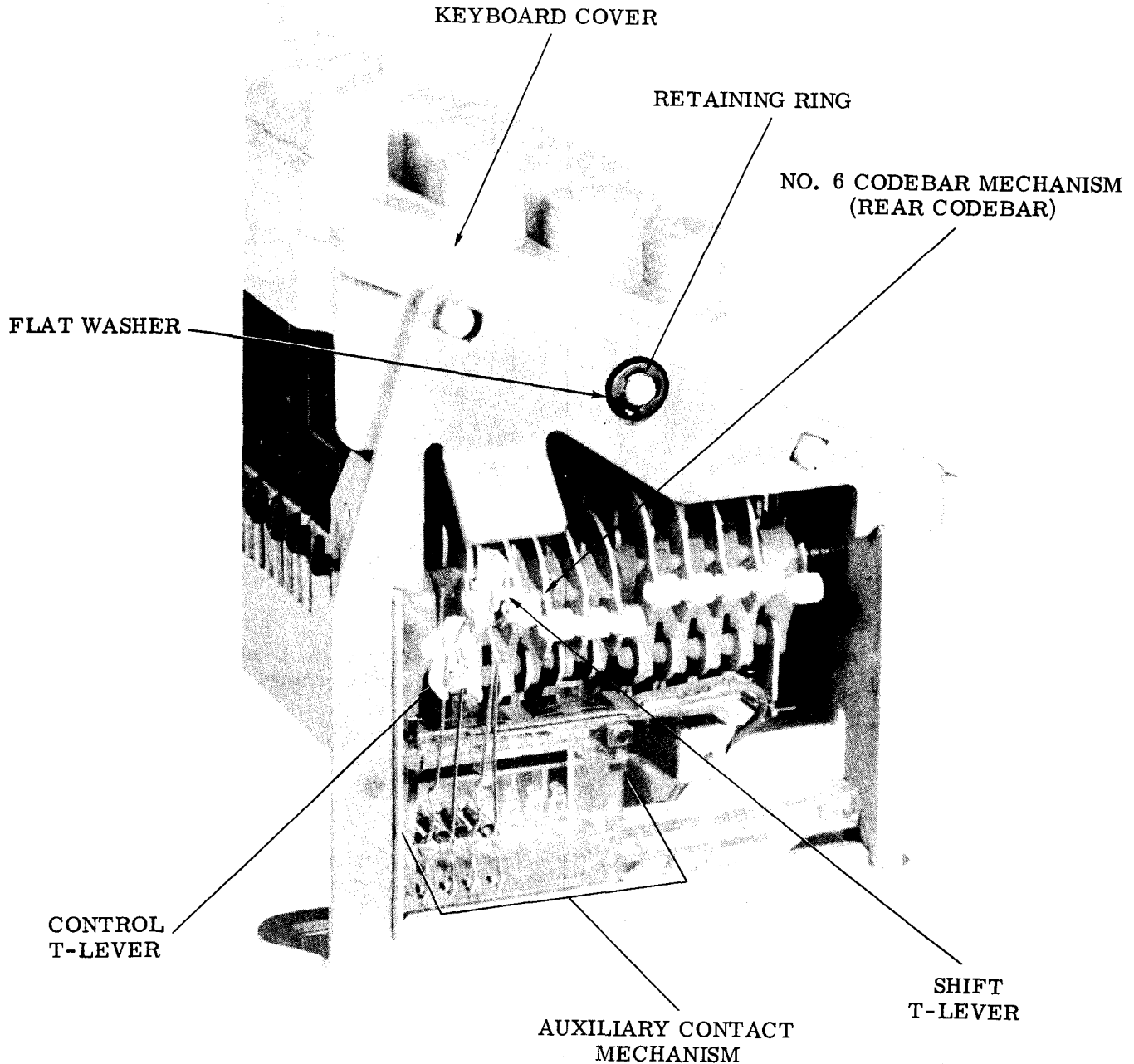

Figure 2 - Auxiliary Contact Mechanism

- (c) Disengage space keylevers from guide slots and remove them from frame.

Note: Careful attention should be given to the position of compression springs on keylever's lower stems so that they can be properly replaced during reassembly.

- (d) To replace spacebar, reverse procedure used to remove it.

CODEBAR

- 2.04 To remove any codebar (Figure 1), proceed as follows.

- (a) Remove all keylevers from typing unit.
- (b) Disengage codebars from left and right T-levers and remove them from keyboard frame.
- (c) To replace codebars, reverse procedure used to remove them.

KEYBOARD CONTACT MECHANISM

- 2.05 To remove keyboard contact mechanism (Figure 1), proceed as follows.

- (a) Disengage the TP185798 (early design) or TP186437 nonrepeat lever spring and the TP82442 (early design) or TP186435 universal lever spring.
- (b) Remove the right side bracket by snapping it off the frame.
- (c) Remove the contact mechanism.

Note: Careful attention should be given to the position of the TP180031 compression springs so that they may be properly replaced during reassembly.

- (d) To replace the keyboard contact mechanism, reverse the procedure used to remove it.

Note: Be sure that the TP180046 contact reset bail operating arm is located beneath the TP182240, TP185766 or TP186253 universal lever after reassembly.

AUXILIARY CONTACT MECHANISM

- 2.06 To remove auxiliary contact mechanism (Figure 2), proceed as follows.

Note: These instructions apply only to parity keyboards.

- (a) Remove left side bracket by snapping it off frame.
- (b) Disengage the TP42661 (early design) or the TP186339 (late design) shift codebar link spring.
- (c) Spread keyboard frame and remove the auxiliary contact.
- (d) To replace the auxiliary contact mechanism, reverse the procedure used to remove it.

T-LEVER SHAFTS

- 2.07 To remove the T-lever shafts (Figure 1), proceed as follows.

- (a) Disengage the TP84575 universal link spring.
- (b) Remove corresponding side bracket; spread the frame and lift out.

Note: If it is desired to remove T-levers, remove the TP119653 retaining rings and slide levers off their shafts.

- (c) To replace the T-lever shafts, reverse the procedure used to remove it.

3. DISASSEMBLY AND REASSEMBLY OF LOCKING MECHANISM IN KEYBOARDS FOR COMPUTER INPUT/OUTPUT SETS (Figure 3)

- 3.01 Remove TP119648 retaining ring. Remove TP186834 lever from post. Remove TP86079 felt washer.
- 3.02 Remove the solenoid plunger with the TP186834 lever attached to it.
- (a) Remove TP119648 retaining ring from the TP183852 pin.
- (b) Remove the TP183852 pin.

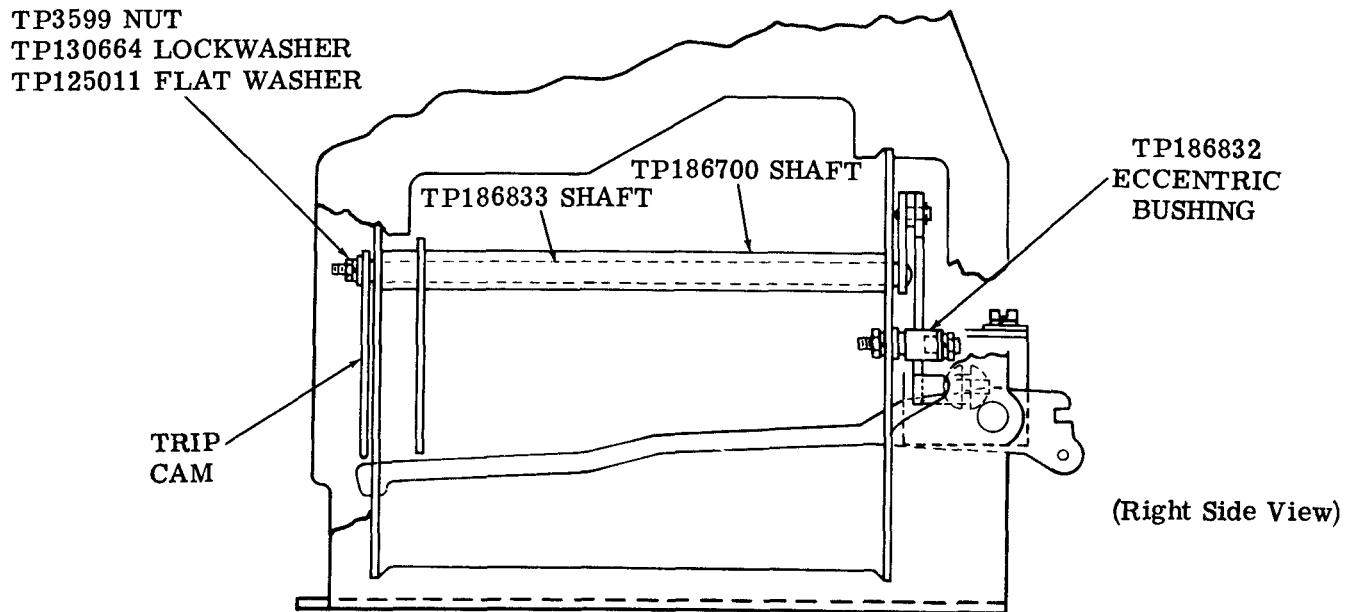
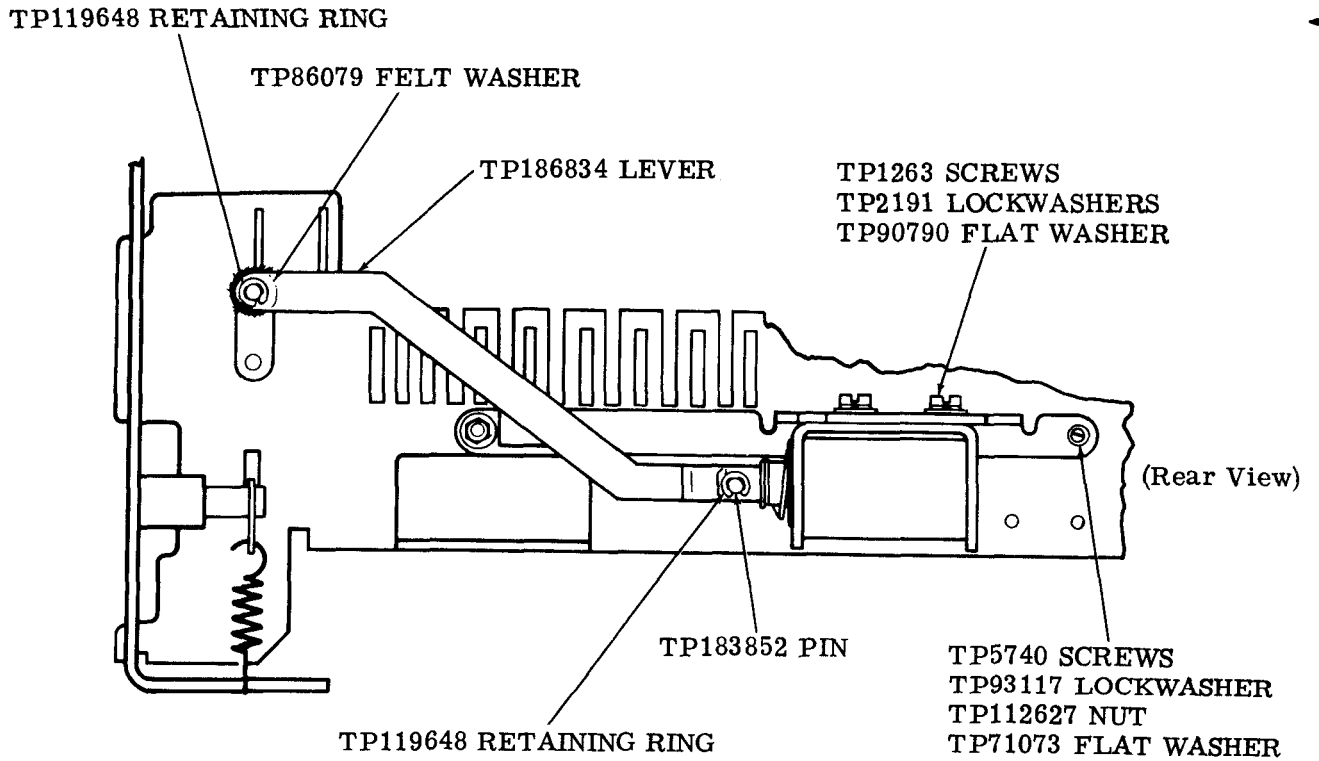

Figure 3 - Locking Mechanism for Keyboards of Computer I/O Sets

→ (c) Remove the TP186834 lever from the slot in the solenoid plunger.

3.03 Remove TP186832 eccentric bushing from the stud on the TP186830 mounting bracket.

3.04 Disassemble trip cam by removing TP3599 nut, TP130664 lockwasher, and TP125011 flat washer.

3.05 Remove TP186833 shaft with lever from within the TP186700 shaft by pulling at → the TP186833 from the rear of the keyboard.

→ 3.06 Remove solenoid from its mounting bracket by removing two TP1263 screws, two TP2191 lockwashers, and two TP90790 flat washers.

3.07 Remove the solenoid mounting bracket with stud from the keyboard frame by removing the TP5740 screw, two TP93117 lockwashers, two TP112627 nuts, and TP71073 flat washer.

3.08 To reassemble the locking mechanism → it. reverse the procedures used to remove

33 TYPING UNIT

GENERAL DESCRIPTION AND PRINCIPLES OF OPERATION

CONTENTS	PAGE
1. GENERAL	1
2. DESCRIPTION	1
TECHNICAL DATA	1
3. TELETYPEWRITER SIGNALING CODE	3
4. PRINCIPLES OF OPERATION	3
OUTLINE OF OPERATION	3
DETAILED OPERATION	8
A. Motor	8
B. Main Shaft	8
C. Clutches	8
D. Signal Reception	9
E. Distributor Mechanism	9
F. Selector Mechanism	11
G. Range Finder	17
H. Codebar Mechanism	17
I. Function Mechanism	19
J. Printing	21
K. Printing Suppressed	27
L. Ribbon Mechanism	29
M. Spacing Mechanism	31
N. Space Suppression Mechanism	32
O. Carriage Return Mechanism	34
P. Paper or Form Feeding	34
Q. Sprocket Feed Typing Units	35
R. Margin Bell and End of Line Bell	39
S. Answer-Back Mechanism	40
5. OPTIONAL FEATURES	47
PRINT NONPRINT	47
A. Magnet Operated	47
B. Solenoid Operated	48

1. GENERAL

1.01 This section provides a general description and the principles of operation for the 33 typing unit. It is reissued to make a few minor corrections, to add a description of the automatic carriage return-line feed for sprocket feed typing units, and to add description of two print nonprint mechanisms. Marginal arrows indicate the changes and additions.

1.02 References to left, right, front, or rear consider the typing unit as viewed by the operator.

1.03 In the illustrations fixed pivots are solid black, and floating pivots — those mounted on parts that move, are crosshatched.

1.04 The 33 typing unit is an electromechanical receiving device which prints graphics on a paper copy according to a code, and performs nonprinting functions.

2. DESCRIPTION

TECHNICAL DATA

Note: This equipment is intended to be operated in a room environment within the temperature range of 40°F to 110°F. Serious damage to it could result if this range is exceeded. In this connection, particular caution should be exercised in using acoustical or other enclosures.

2.01 Speed 100 words per minute

2.02 Dimensions and Weight (Approximate)

Width 13 inches
 Depth 14 inches
 Height 8 inches
 Weight 40 pounds

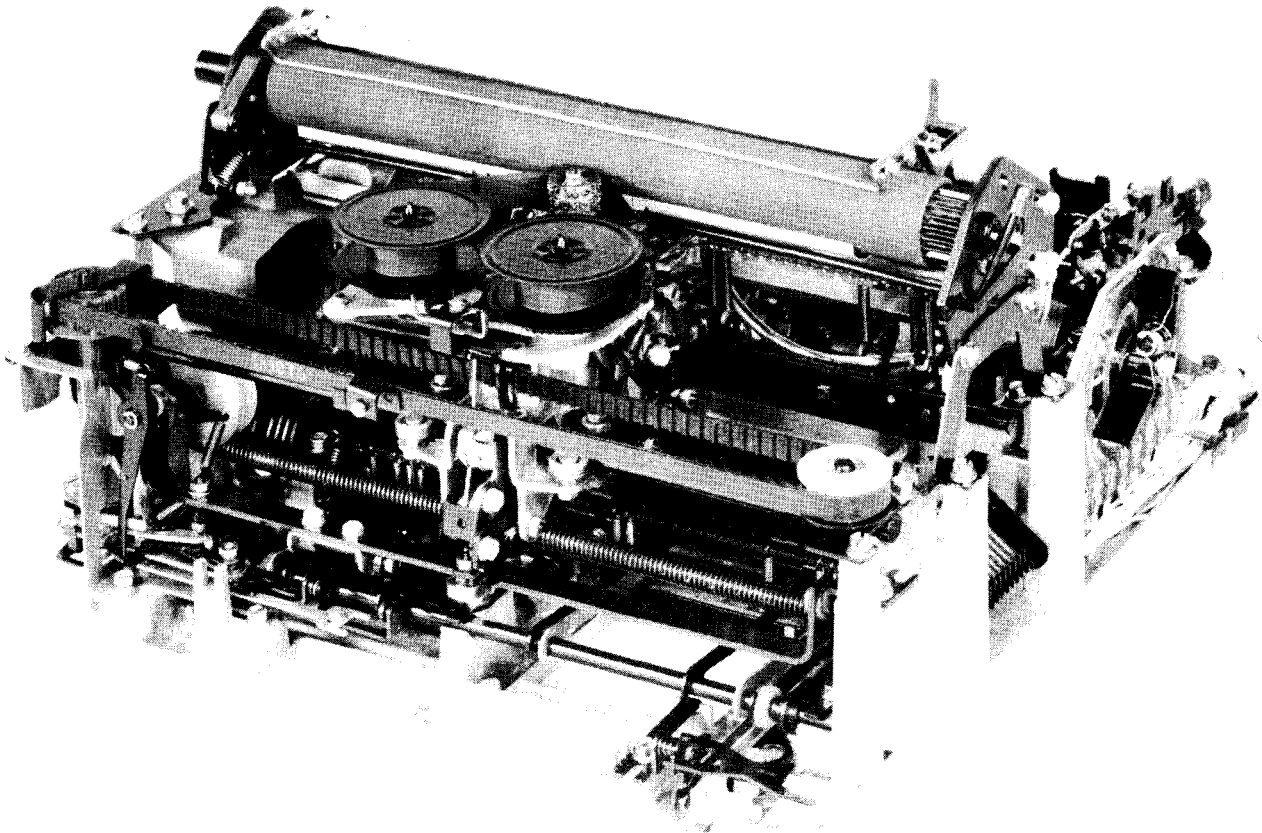

(Right Front View)

Figure 1 - 33 Typing Unit

2.03 Signal Code Characteristics

8-Level
11-Unit Transmission Pattern

2.04 Electrical

Power requirements 115 volts ac $\pm 10\%$
60 Hz ± 0.45 Hz, single phase
Signal line current . . 0.020 or 0.060 ampere
Nominal input to selector . . . 0.500 ampere
at 20 volts dc

Operating margins — all signal contacts
and distributor:

Long telegraph loops . . . 0.015 to 0.070
ampere at 48 to 240 volts dc
inductive
Short telegraph loops 0.58 to 0.72
ampere at 16 to 22 volts dc
resistive

2.05 Printing and Paper or Form Handling

Feed

Friction or Sprocket: Six lines per inch,
adjustable for single
or double line feed

Paper or Form

Friction Feed: 8-1/2 inches wide, max
5-inch diameter roll.
Sprocket Feed: 8-1/2 inches wide; 7-,
8-1/2-, 9-, 10-, 11-, and
12-inch form lengths
or multiples of 1/3 or
1/2 thereof.

Characters and Line

Friction Feed: 10 character per inch,
max 74 character line
Sprocket Feed: 10 characters per inch,
max 72 characters line

Legible Copies

Friction Feed: Original and one copy; when pressure sensitive paper is used, one original and two copies

Sprocket Feed: Original and two copies

2.06 Motor TP181870

Type Synchronous, capacitor start
 Input 115 v ac $\pm 10\%$, 60 Hz, single phase
 Input Current 2 amperes
 Output 33 millihorsepower
 Speed 3600 rpm
 Temperature Rating 130°C
 Power Factor 40%

2.07 Motor TP182241

Type Synchronous, capacitor start and run
 Input 115 v ac $\pm 10\%$, 60 Hz, single phase
 Input Current 1.6 ampere
 Output 33 millihorsepower
 Speed 3600 rpm
 Temperature Rating 130°C
 Power Factor 40%

2.08 Motor TP182267

Type Synchronous, capacitor start and run
 Input 115 v ac $\pm 10\%$, 50 Hz, single phase
 Input Current 1.7 ampere
 Output 35 millihorsepower
 Speed 3000 rpm
 Temperature Rating 130°C
 Power Factor 40%

3. TELETYPEWRITER SIGNALING CODE

3.01 The 33 Teletypewriter transmits and receives messages in the form of a start-stop signaling code. In this code each character or function is represented by current and no current time intervals. Current flowing in the signal line is referred to as marking; no current flowing in the signal line is referred to as spacing.

3.02 To represent a character or a function eleven pulses are used. The first pulse, which is always spacing, is the start pulse.

The next eight pulses are the intelligence pulses. The tenth and eleventh pulses, which are always marking, are the stop pulses. The start and stop pulses are used to synchronize sending and receiving equipment.

3.03 The code used by the 33 typing unit is known as ASCII (American National Standard Code for Information Interchange) and is illustrated in Figure 2. Since it has eight intelligence pulses and three synchronizing pulses it is an 8-level code with an 11-unit transmission pattern.

Start pulse	1 unit of time
Intelligence pulses	8 units of time
Stop pulses	2 units of time
	<u>11-unit code</u>

3.04 The ASCII utilizes only the first seven intelligence pulses, the eighth being used to provide an error detection feature called "even parity." When "even parity" is not provided, the eighth intelligence pulse is always transmitted as a marking pulse. With seven intelligence pulses available, ASCII can accommodate 2⁷ or 128 permutations. Of these 64 are assigned to printing characters. The rest are devoted to nonprinting characters, or are unassigned.

3.05 The character arrangement for ASCII is shown in Figure 2. The black circles represent marking pulses, the blank squares spacing pulses. The main block gives the arrangements of pulses 1 through 5. The four smaller blocks at the right give the arrangements of pulses 6 and 7 for the four rows of characters as indicated by the arrows. When "even parity" is provided, characters and functions which have white backgrounds in the character arrangement illustration have the eighth intelligence pulse spacing — dark backgrounds have the eighth intelligence pulse marking. For keyboard transmission, two SHIFT keys and a CTRL key are used as described in the keyboard section.

4. PRINCIPLES OF OPERATION

OUTLINE OF OPERATION (Figure 3)

Power Distribution

4.01 Operation of the motor switch supplies ac power to the motor. By means of intermediate drive parts the rotary motion of the

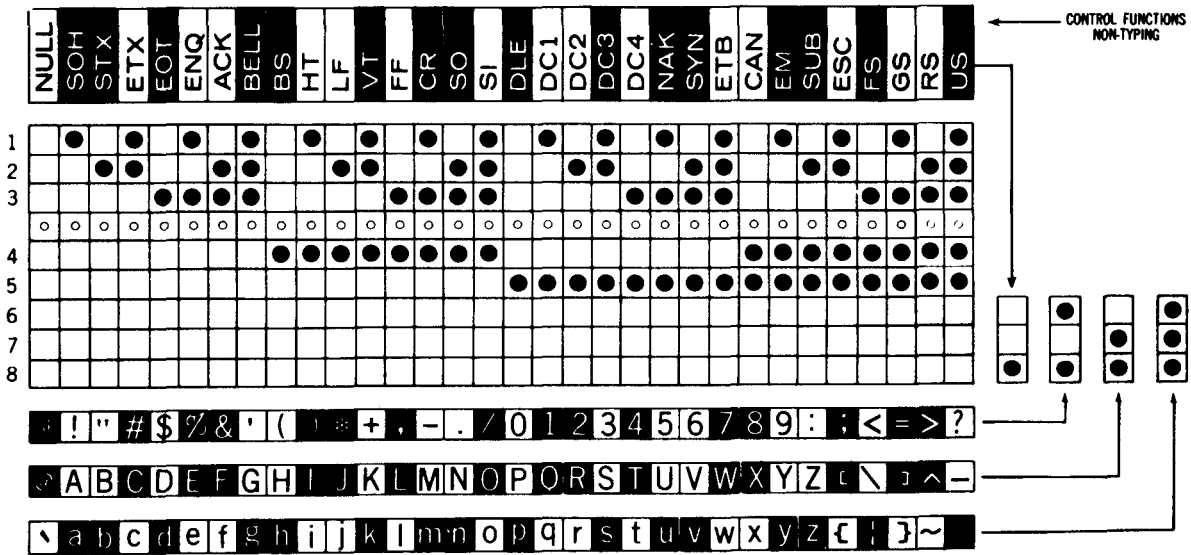

AMERICAN NATIONAL STANDARD CODE FOR INFORMATION INTERCHANGE (ASCII) X3.4-1968

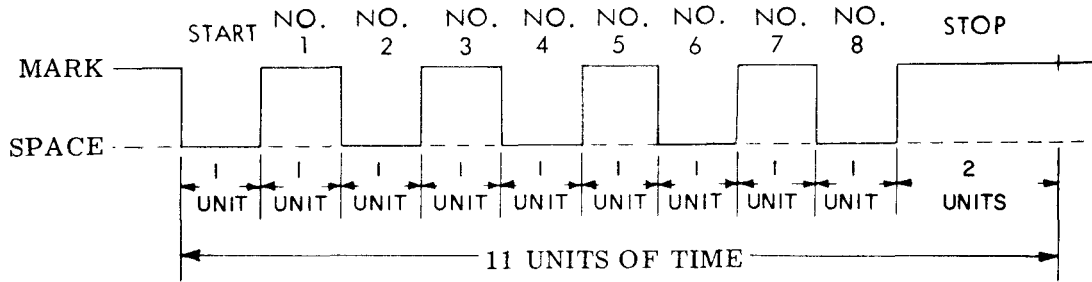

CURRENT WAVE FORM FOR LETTER "U" (WITH "EVEN PARITY")

Figure 2 - Teletypewriter Code (8-Level)

motor is transferred to a distributor shaft. The distributor shaft drives the main shaft and, by means of a clutch, provides motion for the distributor mechanism.

Transmission

4.02 The distributor receives a parallel output from the keyboard and converts it into a serial start-stop code combination. A selector magnet driver receives the distributor serial output and converts it into a form suitable to operate the selector mechanism. The selector mechanism in turn receives the signal and positions the codebar mechanism.

Function Mechanism

4.03 Controlled by the codebar mechanism, the function mechanism enables the typing unit to perform functions supplementary to printing. The standard functions are "space," "carriage return," "line feed," "blank," and "bell."

Spacing Mechanism

4.04 The spacing mechanism positions the carriage so that the characters are properly located horizontally on the paper. It spaces the carriage each time printing occurs and when

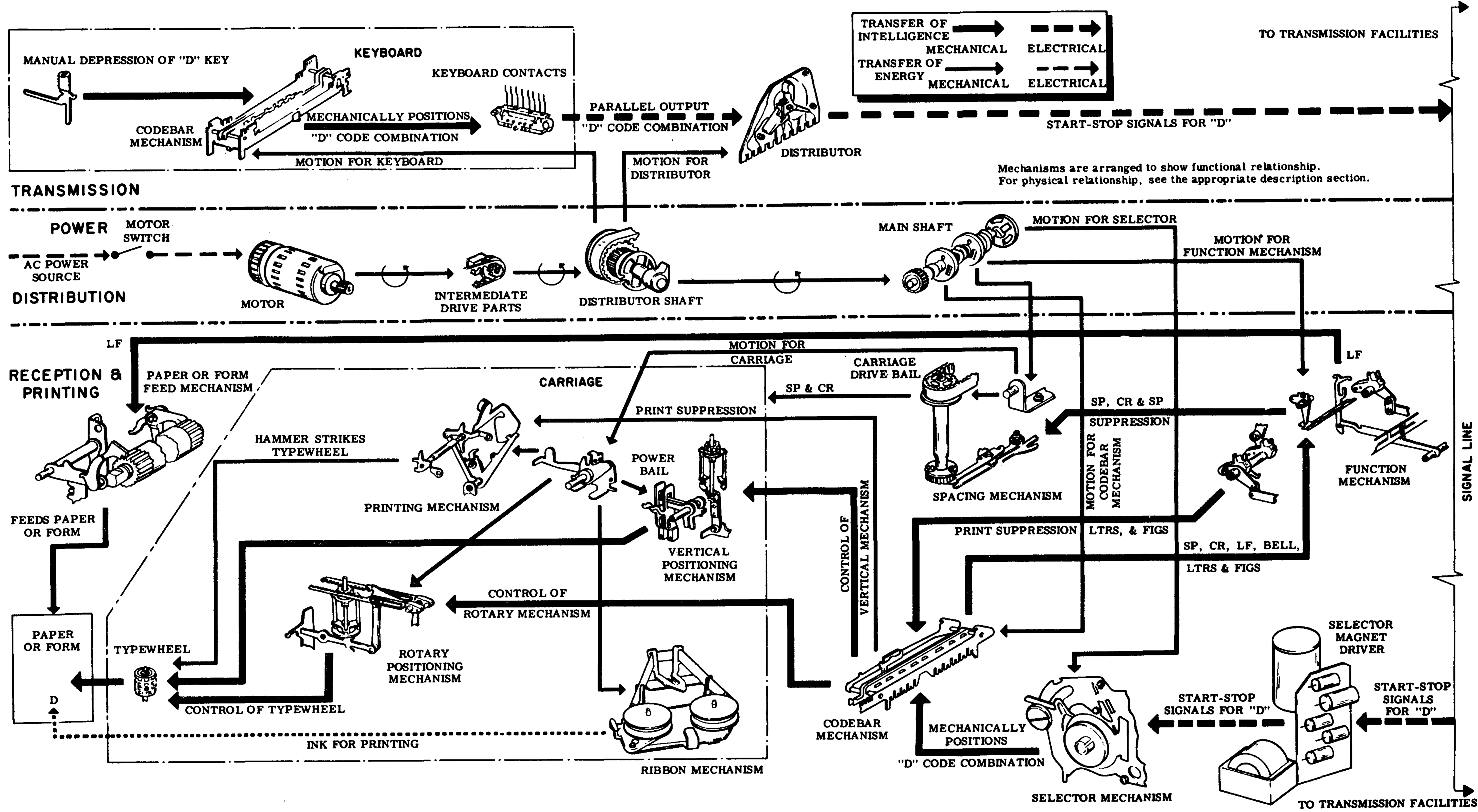

Figure 3 - Schematic Diagram - Typing Unit Operation

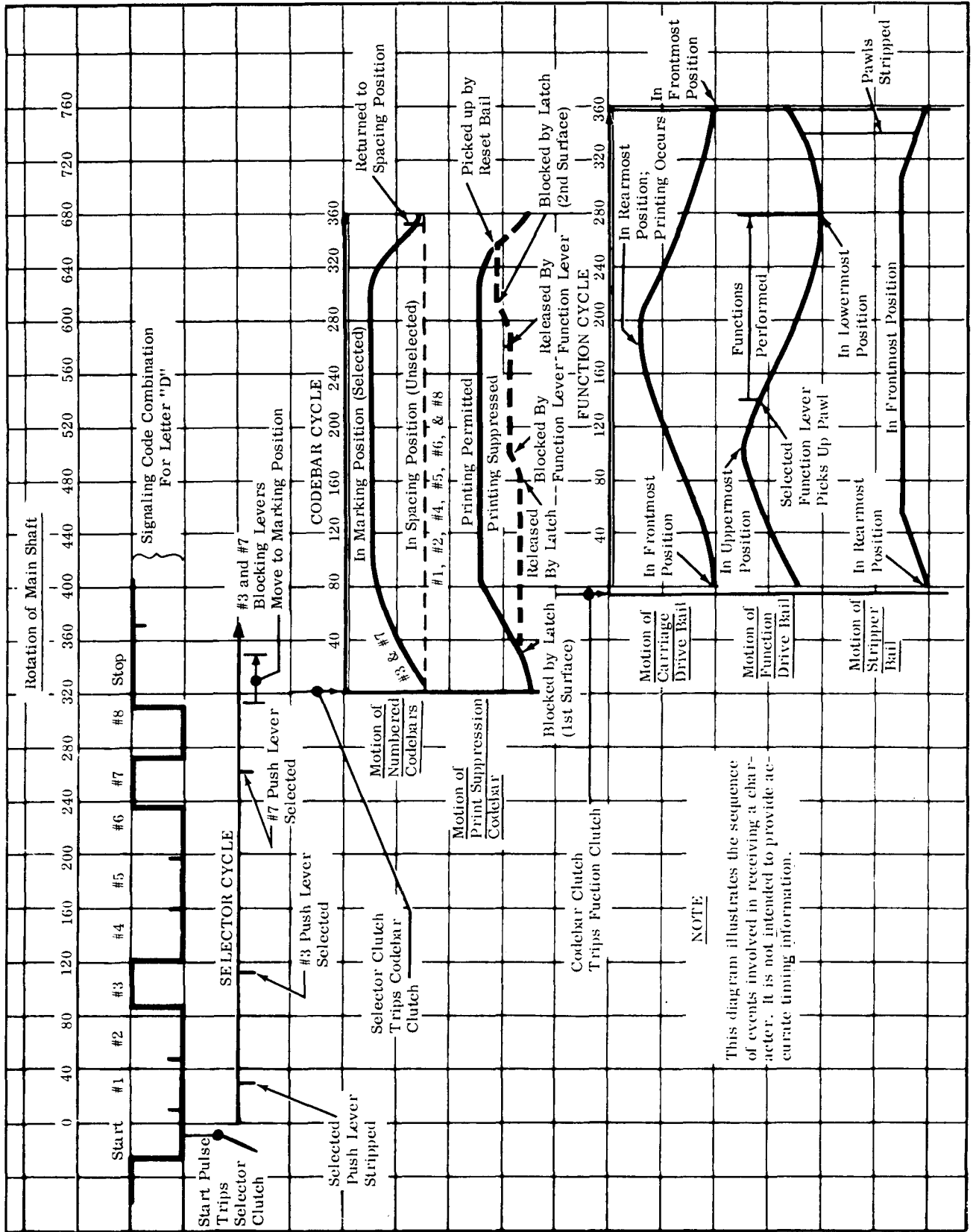

Figure 4 - Sequence Diagram — 33 Typing Unit Operation

the "space" code combination is received. The function mechanism suppresses spacing on the receipt of all functions except "space." At the receipt of "carriage return" code combination, the function mechanism causes the spacing mechanism to return the carriage to the left margin, so that a new printing line can be started.

Paper Feed Mechanism — Friction Feed Typing Units

4.05 The paper feed mechanism positions the paper vertically so that the characters are properly located in lines on the paper. At the receipt of the "line feed" code combination, the function mechanism causes the line feed mechanism to raise the paper to the next printing line.

Form-Feed Mechanism — Sprocket Feed Typing Units

4.06 The form-out mechanism positions the form vertically so that the characters are properly located in lines on the form. At the receipt of the "line feed" or "form out" code combination, the main shaft, through a line feed clutch, causes the platen to raise the form to either the next printing line or one form length, depending upon which function ("line feed" or "form out") is used.

DETAILED OPERATION

A. Motor

4.07 The motor used on the 33 typing unit has a run winding and a start winding connected in parallel. (See the appropriate schematic wiring diagram.) The start winding is in series with an electrolytic capacitor and the contacts of a current-sensitive start relay. The run winding is connected to a run capacitor. When the motor circuit is closed, the initial surge of current energizes the relay coil, closing the relay contacts. The magnetic flux produced by the operating and start windings starts the motor turning. As the rotor accelerates, the current, through the windings, capacitor, and relay decreases. When it drops to a predetermined level, the relay coil opens the contacts and removes the start coil from the circuit. Using the operating coil alone, the motor continues to accelerate until it reaches synchronous speed.

4.08 The rotary motion produced by the motor is transferred through a motor pinion, an intermediate gear pulley, and a motor belt to a distributor gear pulley. The latter drives a main shaft gear and also a distributor clutch, which provides motion for the keyboard and distributor mechanism (Figure 5).

B. Main Shaft

4.09 The main shaft illustrated in Figure 6 receives motion from the motor, and by means of clutches distributes it to drive all the mechanisms in the typing unit except the distributor mechanism. The distributor mechanism is driven by the motor directly as explained in 4.08. In friction feed typing units the main shaft drives three clutches: the selector clutch, the function clutch, and the codebar clutch. In sprocket feed typing units the main shaft drives an additional clutch — the form feed clutch.

C. Clutches

4.10 The clutches used on the 33 typing unit are all metal internal expansion clutches. A clutch is illustrated in Figure 7. This type of clutch functions like brakes. When the clutch is tripped (engaged) two shoes expand against a notched drum. The force of the expanded shoes against the clutch drum is enough to engage the drum. As the drum rotates, the whole clutch and any mechanism attached to it will rotate.

4.11 The clutch drum is attached to and rotates with a shaft. In the stop (or disengaged) position, a trip lever and a latch lever hold the shoe lever, two shoes, a cam disc, and a cam sleeve stationary. When the trip lever moves away from the shoe lever, the shoe lever, under spring tension, moves away from the stop lug on the cam disc. By means of two lugs, the shoe lever expands the shoes until they contact the notched surface of the drum. The drum causes the shoes to rotate. By means of a lug on the cam disc the shoes rotate the disc and the sleeve attached to it. The clutch is now engaged, and the cam sleeve rotates in unison with the shaft.

4.12 When the trip lever moves to its stop position, it is struck by the shoe lever. The cam disc continues to rotate until the latch lever seats in its notch, and the shoe lever and stop lug are pressed together by the trip lever and latch lever. A spring holds the shoes together, away from the drum. The clutch is now disengaged.

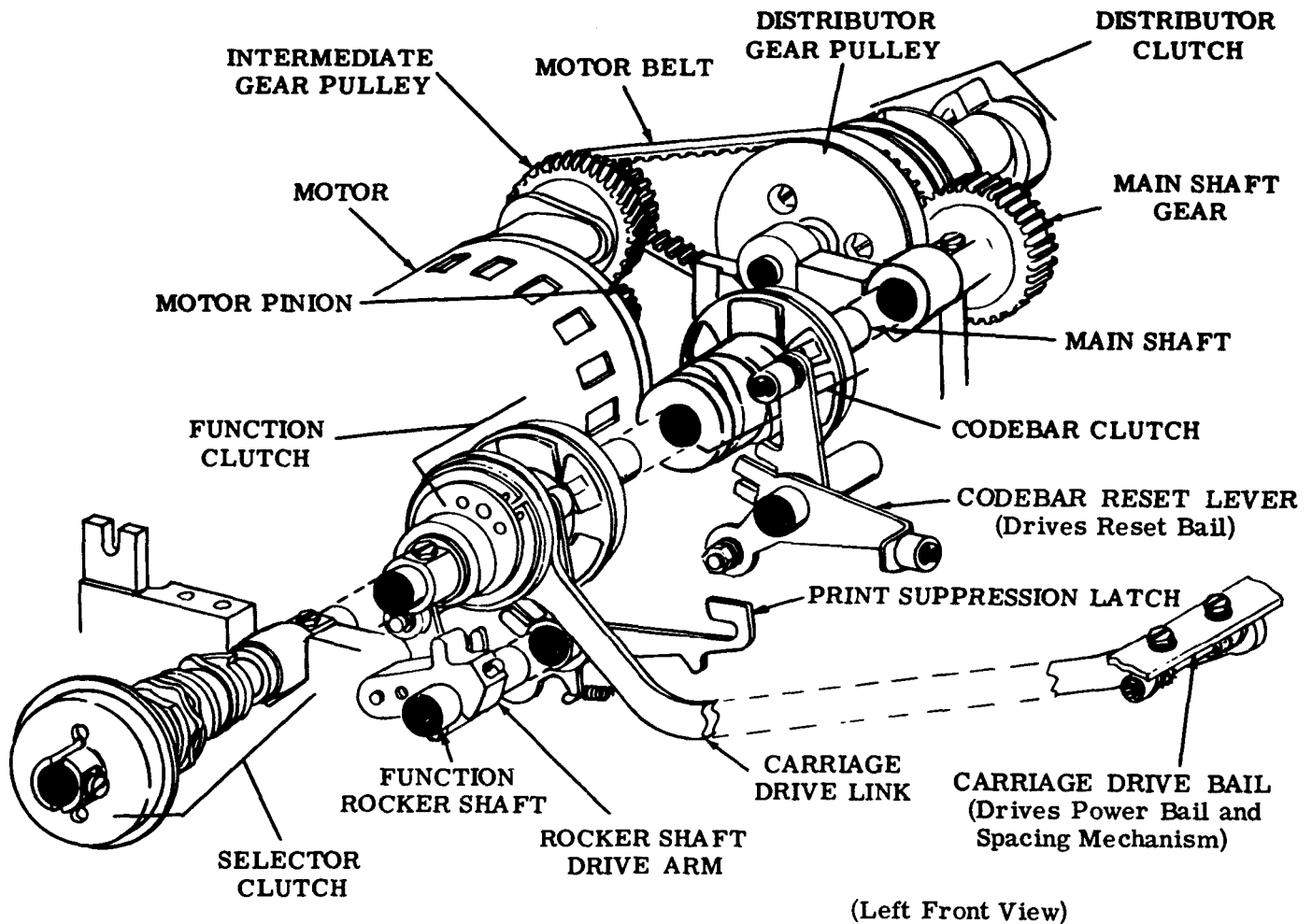

Figure 5 - Motor and Drive Mechanism

D. Signal Reception

4.13 The signal received by the typing unit may originate either remotely or locally. Locally the signal may originate either in the keyboard or the tape reader. In either case, the incoming signal is received as a parallel output to the distributor. The distributor changes the parallel signal into a serial start-stop output to the selector magnet driver for current rectification. The signal goes from the selector magnet driver to the selector. The following paragraphs will consider the signal as originating in the keyboard. Refer to Section 574-121-100TC for the description of keyboard operation.

E. Distributor Mechanism

4.14 The distributor mechanism is illustrated in Figures 8 and 9. When a keytop is depressed, the corresponding code combination is set up in the keyboard contacts. Simultaneously the universal lever moves up. An H-plate connects the universal lever of the keyboard to the distributor clutch trip linkage in the typing unit. As the universal lever moves up, the H-plate pivots the distributor trip linkage. The distributor trip linkage is connected to the clutch trip lever. As the linkage moves rearward the trip lever is moved away from the shoe lever and the distributor clutch engages.

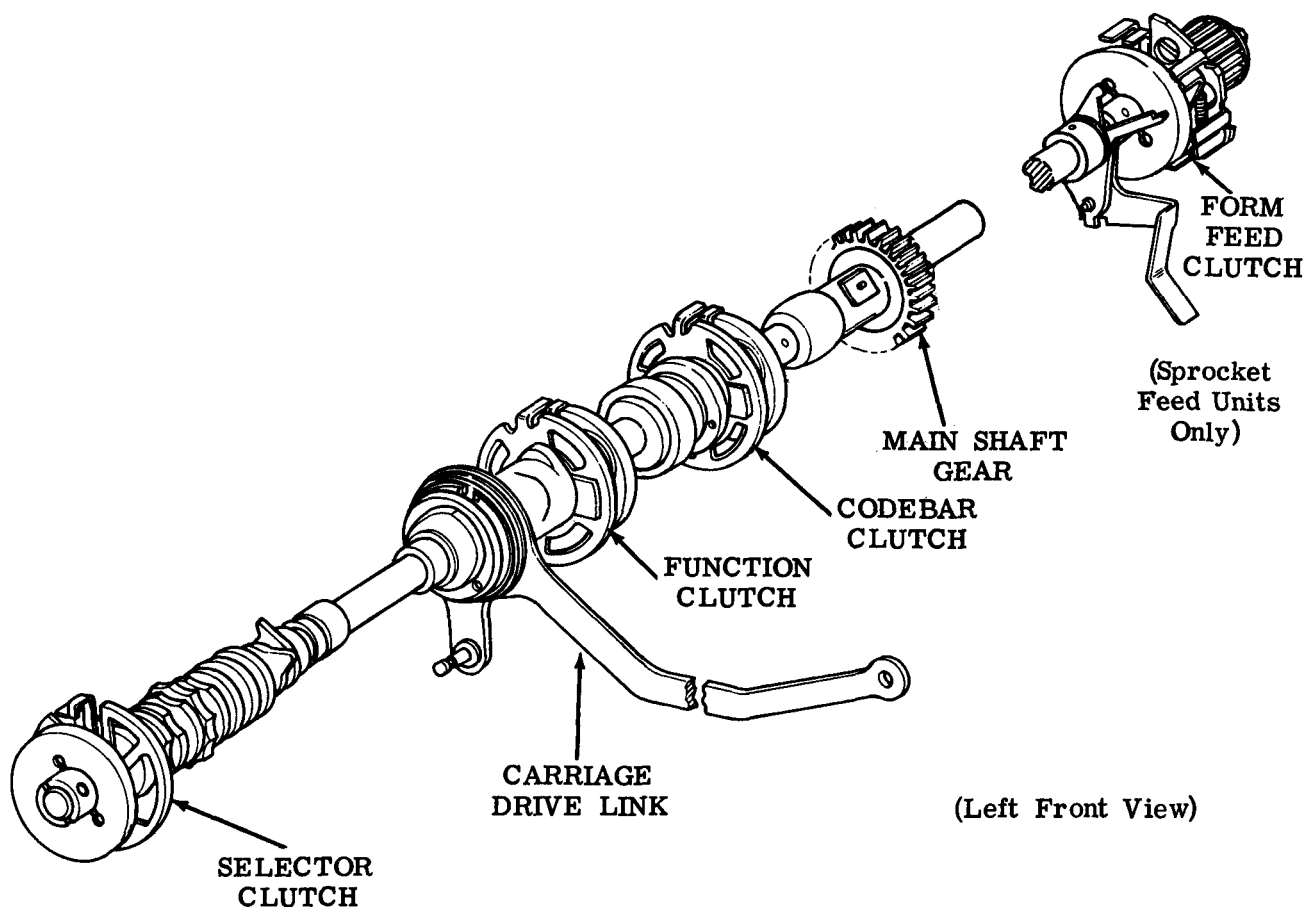

Figure 6 - Main Shaft

4.15 The clutch disc is attached to the distributor shaft. A brush holder mounted at the end of the distributor shaft rotates two carbon brushes over the segments of the distributor disc. A spring fastened to the brush holder serves two purposes: it holds the carbon brushes firmly against the segments, and serves to close the current loop between the outer and inner rings of the distributor disc.

4.16 The distributor disc has two rings. The inner ring is solid. The outer ring is broken into ten segments corresponding to the start, stop, and the eight intelligence pulses.

(a) In the stop position, the outer brush rests on the stop segment, and the current flows in the signal circuit which is closed. (The signal path is from one side of the line through the start segment, the inner ring, the brushes, the stop segment, the common terminal, and the break contact to the other side of the line.) Thus a marking condition exists. Assume that the D key is depressed. The (--3---7-) code combination is set up in the keyboard contacts.

(b) The distributor clutch is tripped, and the brush holder begins its revolution. While the brush is on the start segment, the

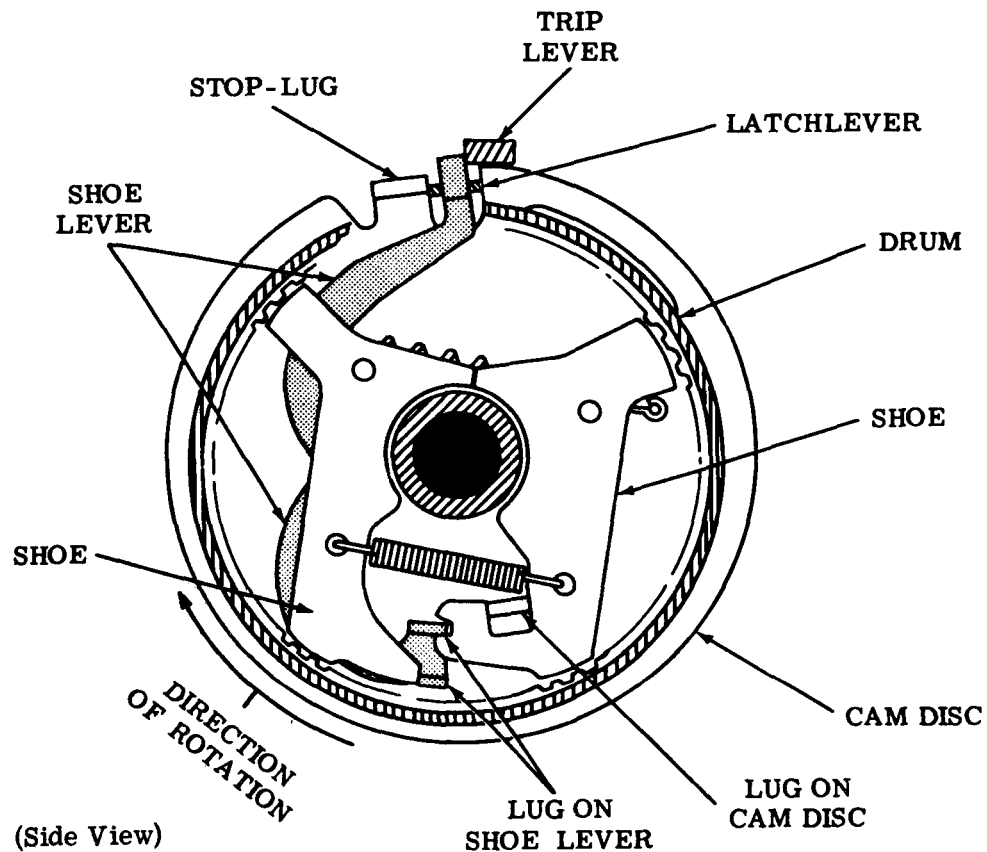

Figure 7 - Internal Expansion Clutch

circuit is open, no current flows, and a spacing element is transmitted. While it is on the no. 1 segment, the circuit is again open. Likewise the circuit is open for the no. 2 pulse. On the no. 3 segment the circuit is closed, current flows and a marking element is transmitted. For the nos. 4, 5, and 6 segments the circuit is open, transmitting spacing elements. The circuit closes for the no. 7 element and opens for the no. 8. When the brush reaches the stop segment, the distributor clutch is disengaged, and the line again becomes marking.

F. Selector Mechanism

4.17 The selector mechanism illustrated in Figures 10 and 13 receives the code combinations from the selector magnet driver and converts them to mechanical arrangements that control the codebar mechanism.

4.18 A magnet coil is wired by two leads to the output of the selector magnet driver. In the stop condition the output of the selector magnet driver is marking. This keeps the coil energized and the armature attracted to the magnet core. In this attracted position the armature blocks the start lever.

4.19 When a code combination is received the start pulse (spacing) de-energizes the coil, and the armature drops away from the magnet. No longer blocked, the spring biased start lever overtravels the armature, causing two things to happen:

- (a) The start cam follower associated with the start lever falls into the indent of the start cam.
- (b) As the start cam follower falls into the indent, the trip lever associated with it moves away from the clutch shoe lever, allowing the selector clutch to engage.

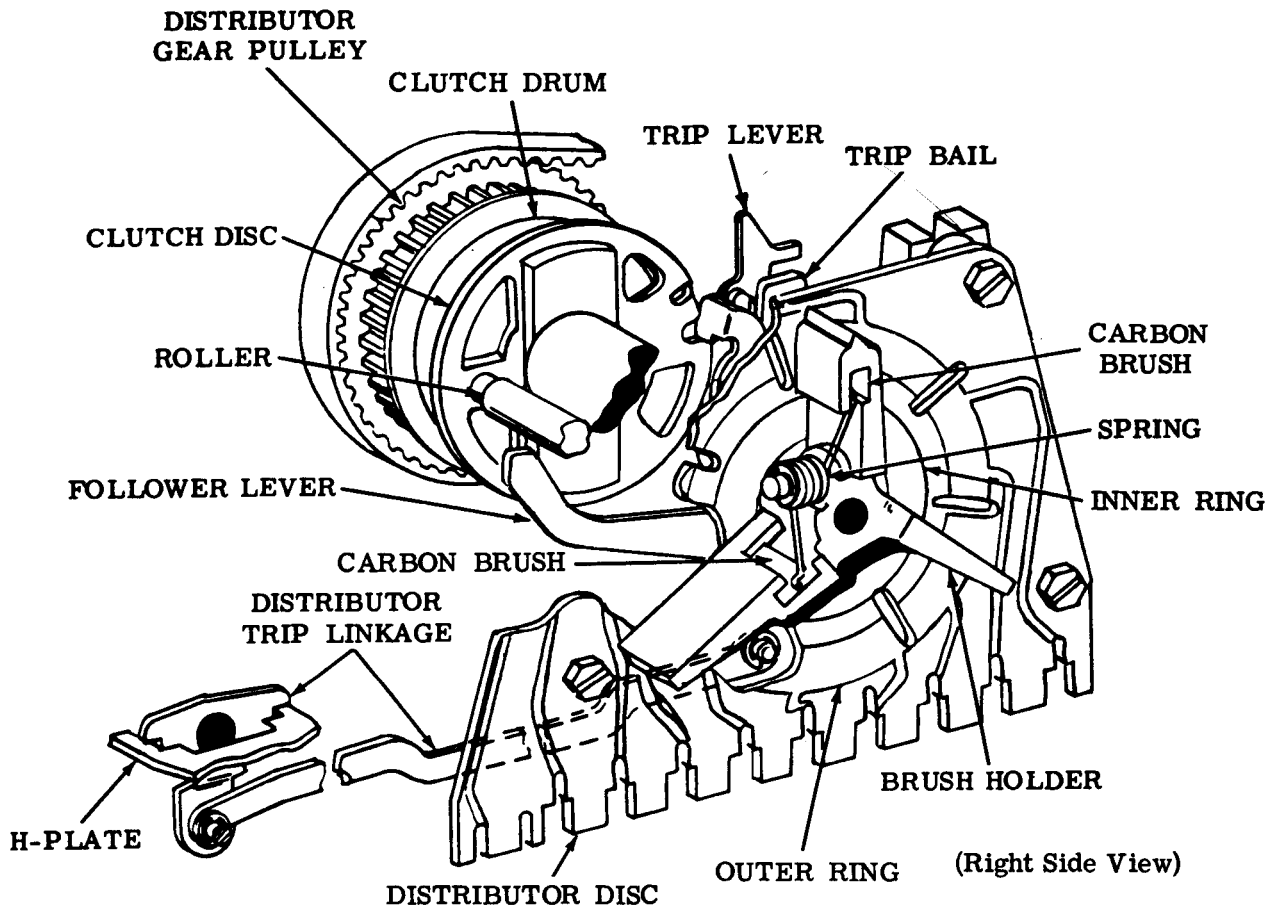

Figure 8 - Distributor Mechanism

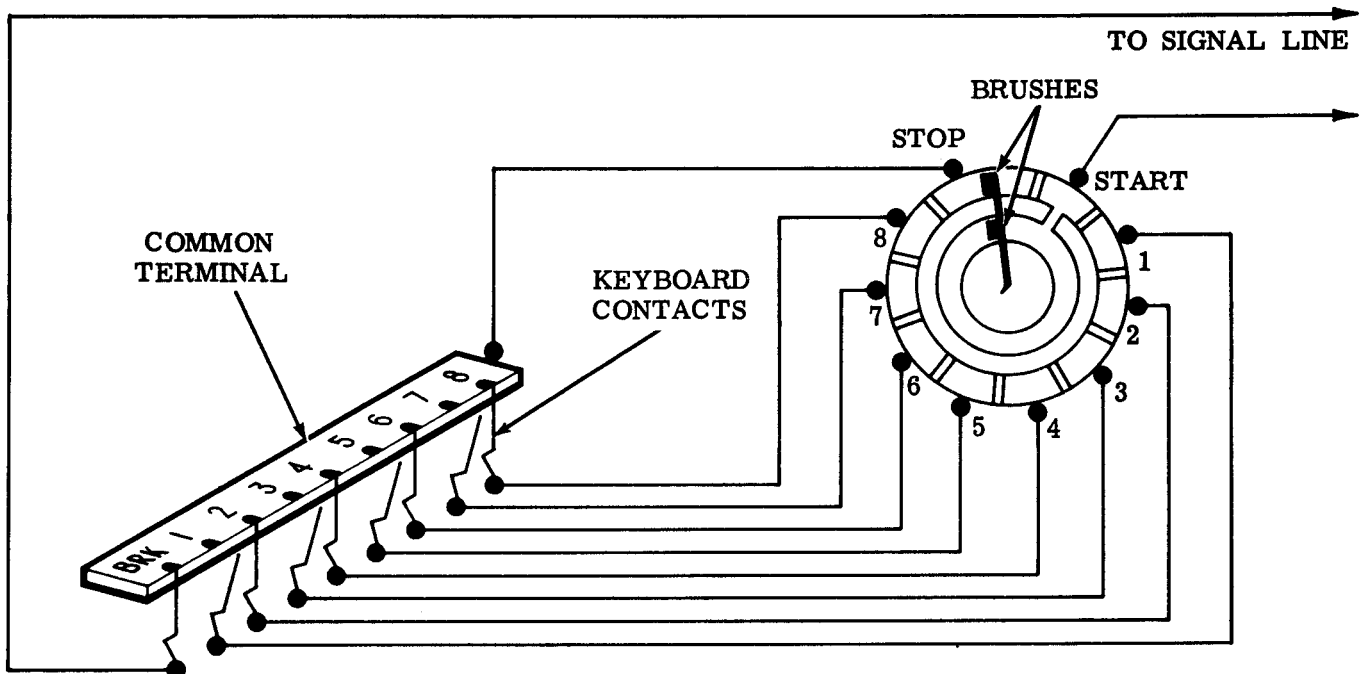

Figure 9 - Signal Wiring for 33 Typing Unit Distributor

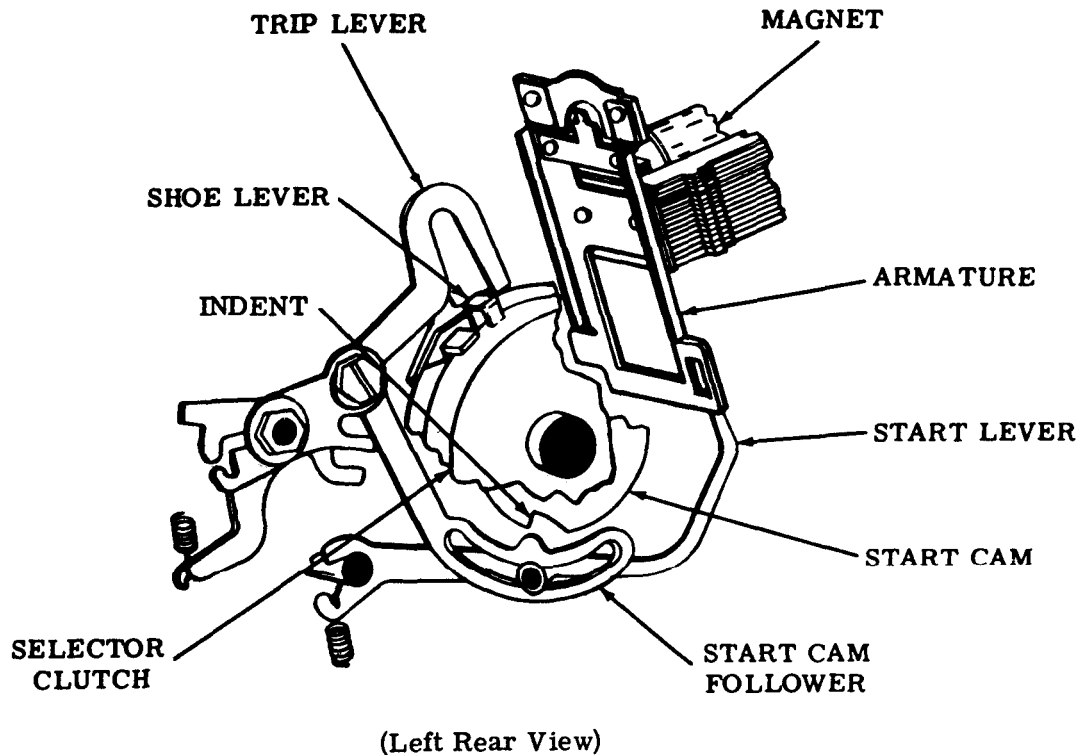

Figure 10 - Selector Trip Mechanism

4.20 Once engaged the selector clutch makes one complete revolution. The start cam follower remains in the indent of the start cam just enough to trip the clutch. It then comes out of the indent and rides the cam. This keeps the start lever away from the armature which will now be attracted if the incoming pulses are marking and unattracted if the pulses are spacing.

4.21 As the selector clutch rotates, the spacing locklever, the push lever reset bail, the codebar clutch trip follower arm, and eight selector levers ride individual cams under spring tension.

4.22 Early in the codebar cycle the high part of the push lever reset cam pivots the push lever reset bail. In its motion the bail

resets all the spring biased push levers selected in the previous cycle. Once reset the push levers can be positioned either marking or spacing as the intelligence pulses are received.

4.23 The selector cam sleeve illustrated in Figure 11 has twelve cam surfaces. The cam surfaces are positioned in a staggered fashion so that a sampling sequence can take place. As mentioned in 4.19 and 4.20, the start cam performs its function, and soon after the push lever reset cam is operated. Following these the spacing locklever cam and the eight intelligence cams operate in sequence.

Note: The sampling sequence for the intelligence cams is as follows: no. 1, 2, 3, 4, 5, 6, 7, and 8. However, the physical arrangement of the cams is: 1, 2, 3, 4, 5, 7, 6, and 8 as viewed from left to right.

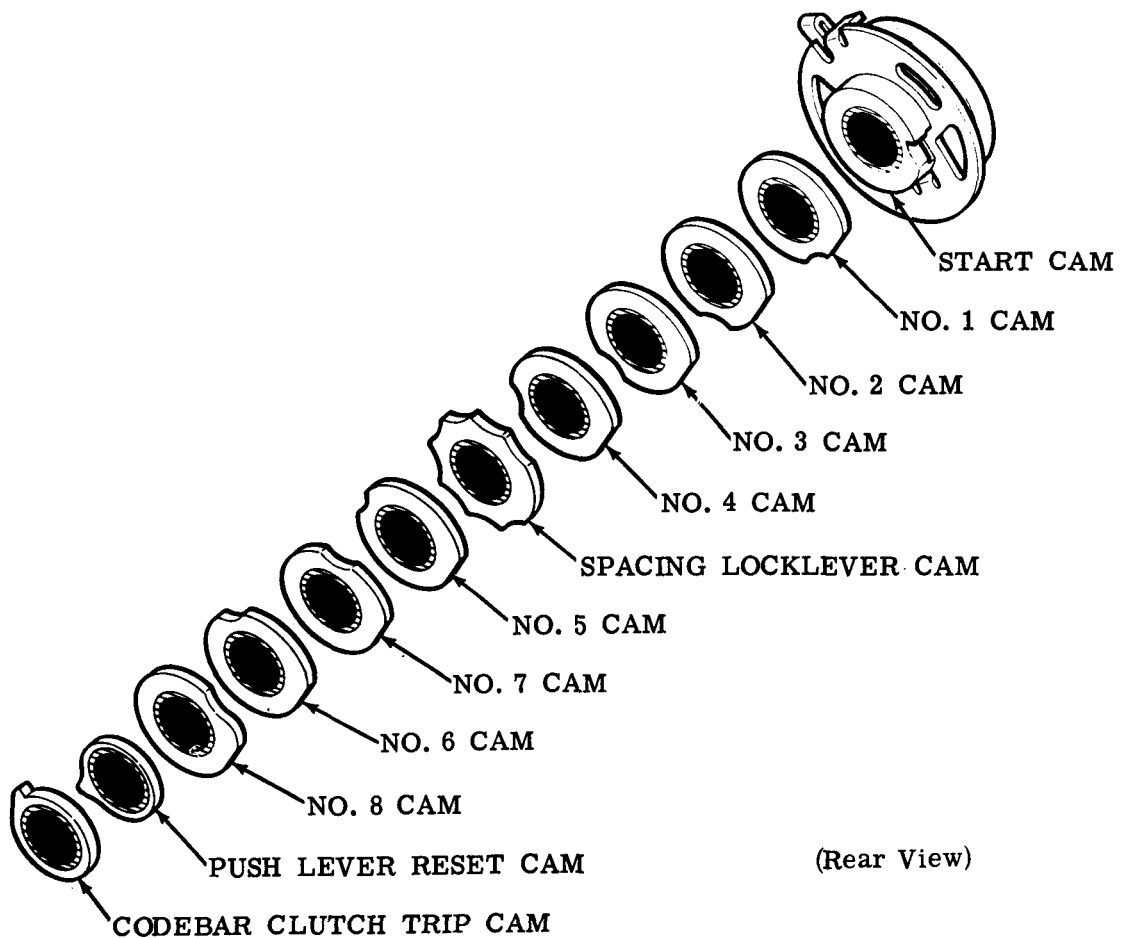

Figure 11 - Selector Cam Sleeve

4.24 If the intelligence pulse is spacing it de-energizes the magnet coil and the armature is in the unattracted position. The spacing lock lever moves up, holding the armature in this position during the sampling interval. The selector lever is prevented from moving up into the indent of its cam by the armature, and the push lever remains in its unselected (spacing) position in front of the selector lever (Figure 13).

4.25 If the intelligence pulse is marking the armature is attracted, moving out of the way of the selector lever, blocking the spacing locklever. The selector lever moves up into the indent of its cam, locking the armature in its marking position during the sampling interval. This permits the spring biased push lever to move rearward under the selector lever.

4.26 As the code combination is received, each intelligence pulse is sampled in turn, and the corresponding selector levers and push levers are positioned accordingly. The contours of the selector cams are such that near the end of the cycle they drive the selector levers and selected push levers towards the front of the typing unit to their marking position. In this position their slotted portions are up. The blocking levers associated with the unselected push levers remain in the spacing position in which their slotted portion is down (Figure 13).

4.27 Near the end of the cycle, the trip follower arm is moved rearward by its cam and trips the codebar clutch.

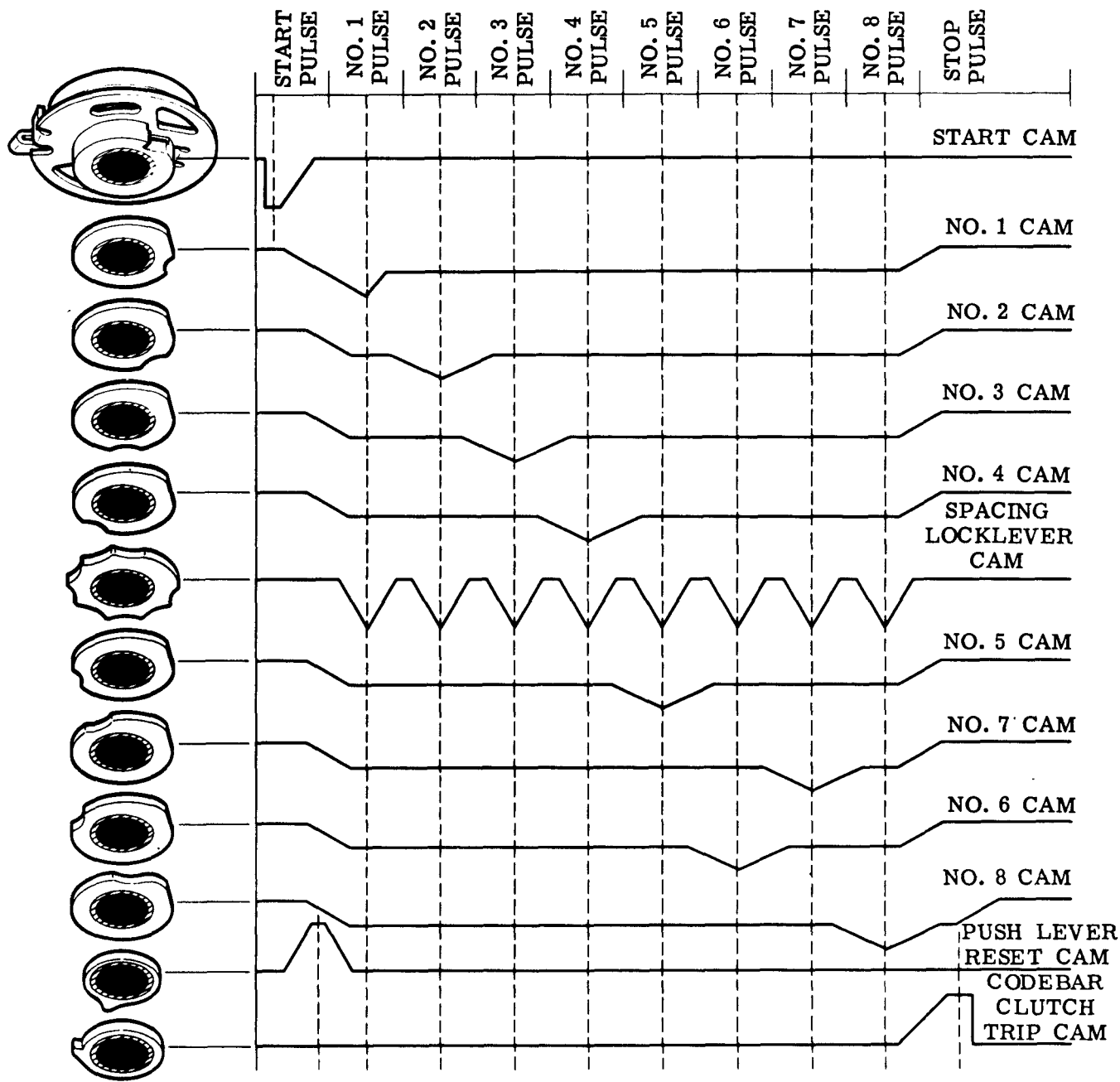

Note: This illustration is intended to show relationships of operations. It is not meant to be a timing chart.

Figure 12 - Sequence and Relationships of Selector Cams Operations

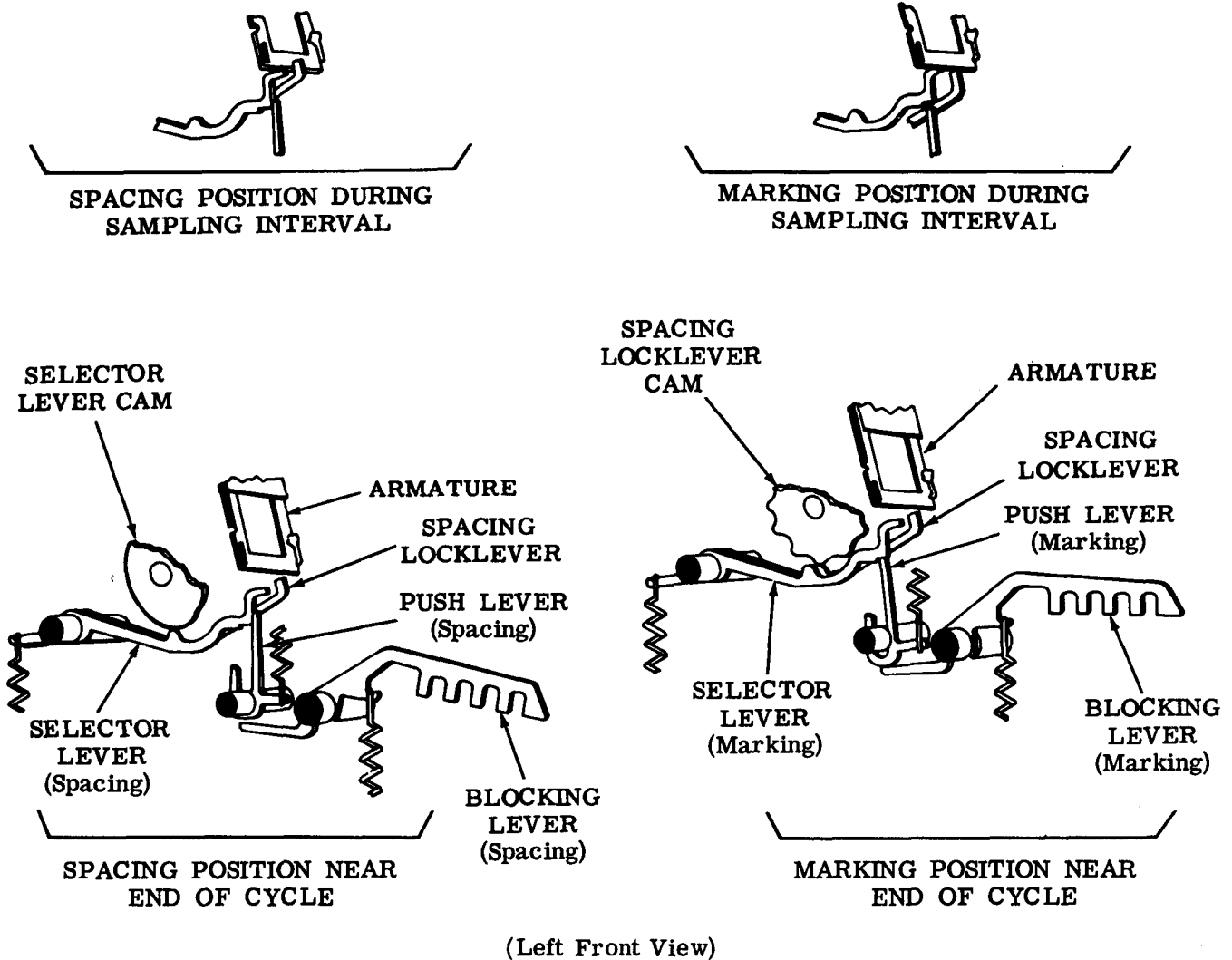

Figure 13 - Selector Mechanism

4.28 When the stop pulse (marking) is received at the end of the code combination, the armature moves to its marking position above the start lever, where it prevents the start cam follower from falling into the indent of its cam. In this position the follower holds the trip lever down so that, when the selector clutch completes its cycle, its shoe

lever strikes the trip lever, and the clutch is disengaged.

4.29 As an example, assume that the letter D (--3--7-) code combination is received by the typing unit. The start pulse (spacing) trips the selector clutch, which begins its cycle. The stripper ball strips all previ-

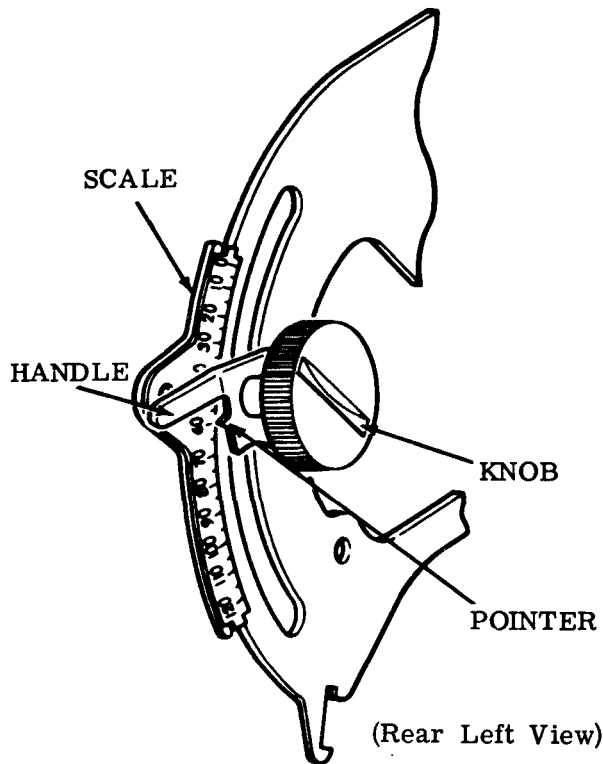

Figure 14 - Range Finder

ously selected push levers from the selector levers. The intelligence pulses are sampled in order, and the no. 3 and no. 7 push levers are selected. Near the end of the cycle the selector clutch cams the no. 3 and no. 7 push levers down, and they pivot the no. 3 and no. 7 blocking levers up to their marking position. The trip cam causes the trip follower arm to trip the codebar clutch. The stop pulse (marking) disengages the selector clutch, and the selector returns to its stop position.

G. Range Finder

4.30 For optimum operation of the typing unit, the selector must sample the code elements at the most favorable time. The range finder illustrated in Figure 14 provides a means of determining this time by establishing a range of operating margins.

4.31 When the range finder knob is loosened, a pointer may be moved along a range scale by a handle. This changes the angular position of the trip levers and latchlevers with respect to the main shaft, and thus changes the position where the selector clutch begins and

ends its cycle. The effect of this operation is to change the time in the cycle when the selector samples each code pulse.

4.32 Rotating the pointer counterclockwise from 60, the center of the scale, causes the selector to sample the trailing portion of the pulse. Rotating the pointer clockwise causes the selector to sample the leading edge. To establish the margins of the operating range, the pointer is moved first in one direction, then in the other, until errors in printing occur. The pointer is then set at the center of the range and the knob tightened.

H. Codebar Mechanism

4.33 As mentioned in 4.27, near the end of the selector cycle (towards the end of the eighth pulse) the codebar clutch trip cam pivots the codebar clutch trip follower arm. The arm, through a trip shaft, pivots the trip lever out of the way of the shoe lever. The codebar clutch engages and makes one revolution.

4.34 As the codebar clutch rotates, the codebar reset lever follows its camming surface under the pressure of the codebar reset bail spring. The rotary motion of the cam is applied as an oscillating motion to the codebar reset lever. The codebar reset lever in turn applies its motion to the codebar reset bail which oscillates from right to left when viewed from the front of the unit.

4.35 There are ten codebars in the codebar mechanism illustrated in Figure 15. The function of the codebars is to sense the marking and spacing positions of the blocking levers. As the reset bail pivots, the codebars move up and to the left to sense the positions of the blocking levers. If a blocking lever is down (spacing) a projection on the blocking lever comes in contact with a projection on the codebar, keeping it in a down position. The operation of individual codebars will be described in succeeding paragraphs in conjunction with other mechanisms. Function levers positioned under the codebars and stop slides riding the top of the codebars will be described later.

4.36 Early in the codebar cycle a trip cam pivots a follower arm which trips the function clutch. Near the end of the cycle the cam, through the reset lever, pivots the reset bail to the left. This allows the codebars to return to their stop (down and right) position.

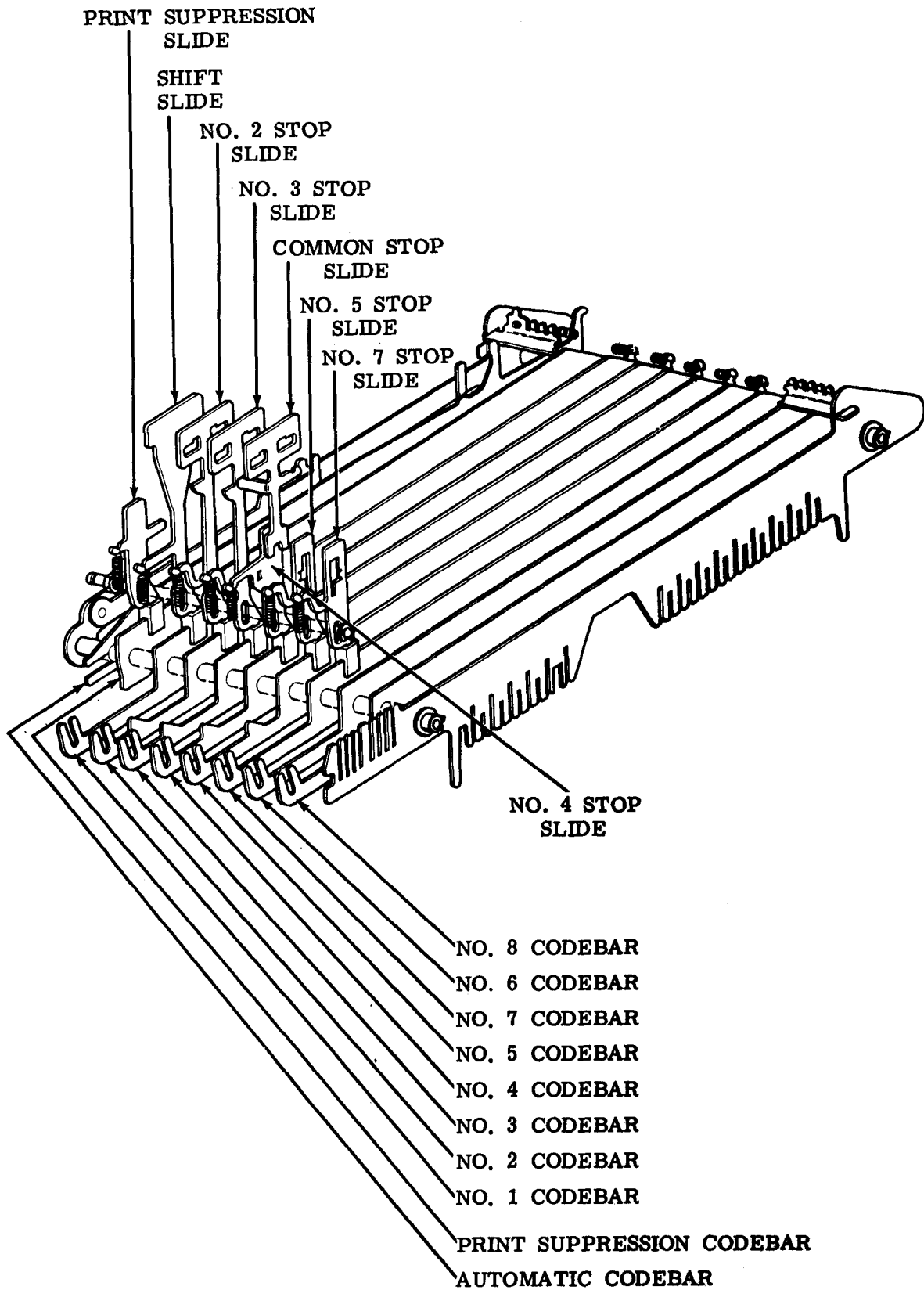

(Front Left View)

Figure 15 - Codebar Arrangement

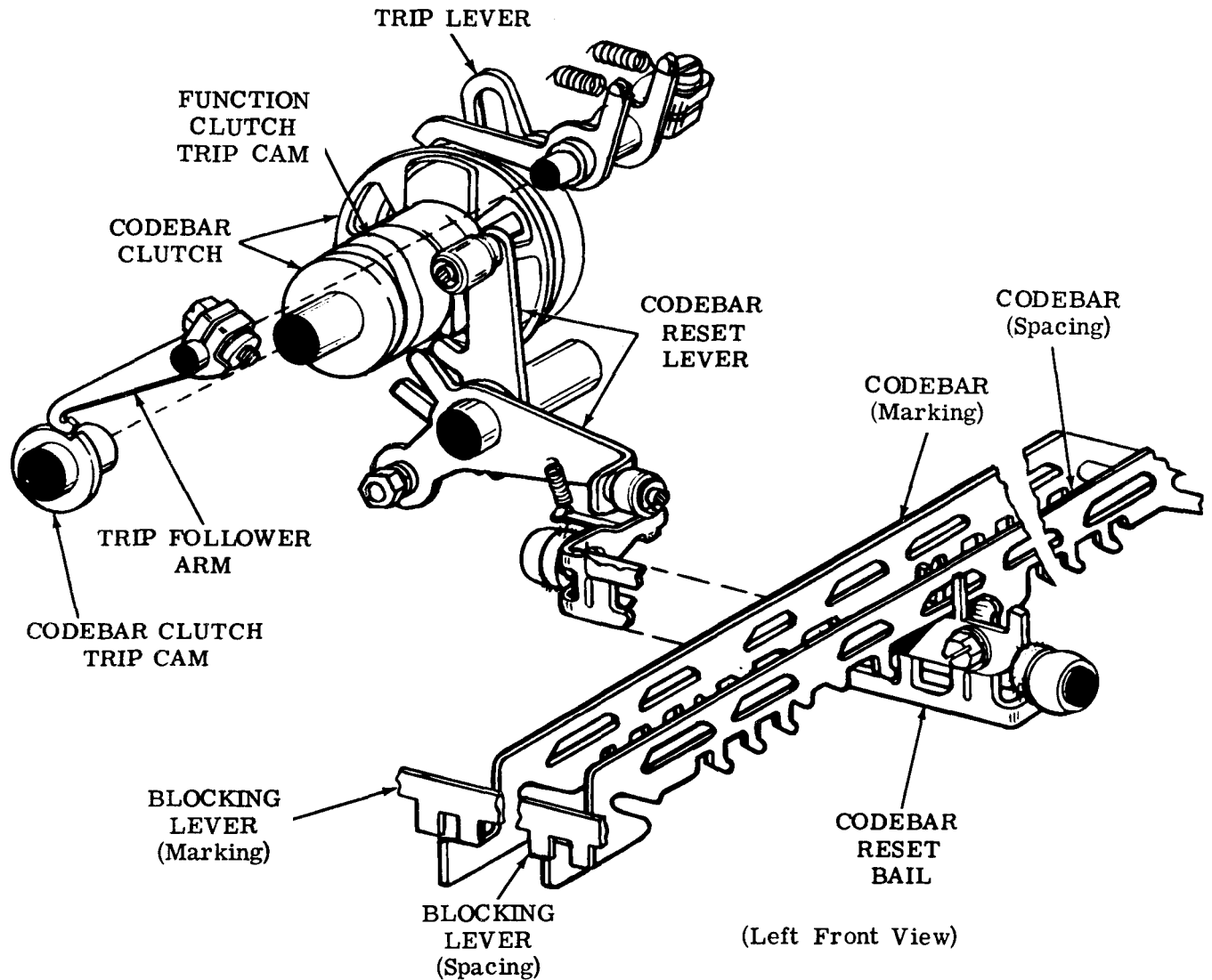

Figure 16 - Codebar Mechanism

I. Function Mechanism

4.37 The function mechanism illustrated in Figure 17 enables the typing unit to perform functions at the receipt of the proper code combinations. Functions are operations supplementary to printing the message, such as carriage return and line feed.

4.38 Early in the codebar cycle a cam pivots the function trip follower arm, which moves the function trip lever out of engagement with its shoe lever. The function clutch engages and makes one complete revolution. The function drive cam, through a follower arm and drive arm, causes the function rocker shaft to rock. The function rocker shaft, through two

drive linkages, moves a function drive bail up during the first part of the cycle and down during the middle portion.

4.39 The underside of the codebars are coded by a series of notches and projections. Under the codebars are a number of function levers which pivot on the same shaft as the function drive bail, and are connected to the bail by springs. As the bail moves up, the springs pull the function levers up so they sense the codebars. If a lever encounters one or more projections, it is retained in its down position against the tension of its spring. If the slots line up such that an opening is provided for a function lever, the lever moves all the way up to its selected position.

4.40 In most cases, when a function lever moves up to a certain level, it is latched by an associated function pawl. Then, when the function drive bail pulls the lever and latched pawl down during the middle portion of the cycle, the pawl provides the motion to effect the function.

4.41 Near the beginning of the function cycle, a cam pivots a drive arm which moves the function stripper bail forward. Near the

end of the cycle the cam permits the drive arm, under spring tension, to move the stripper bail rearward and strip any latched function pawls from their selected function levers.

4.42 The operation of the individual function levers and pawls is covered under the individual functions.

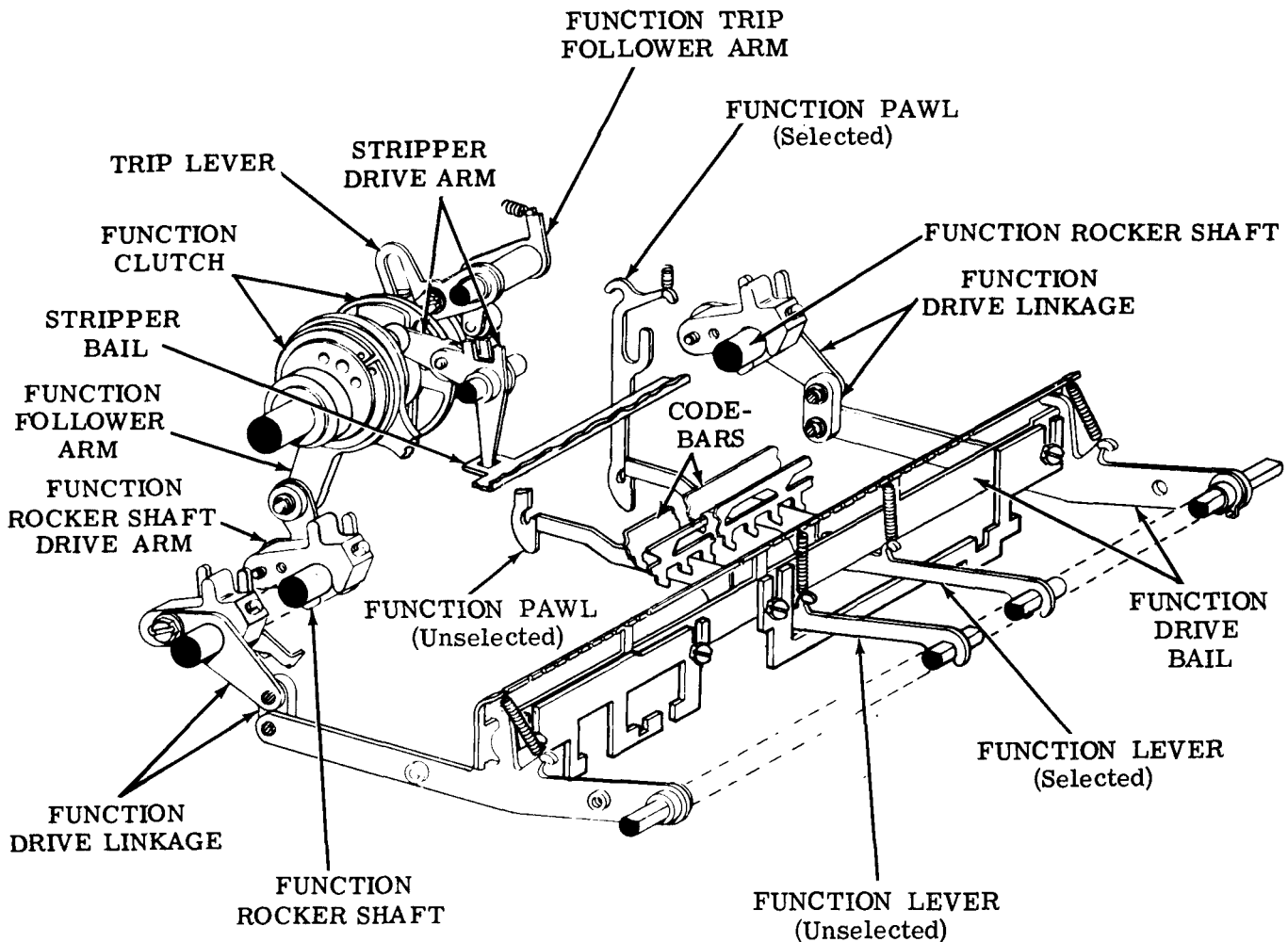

(Left Front View)

Figure 17 - Function Mechanism

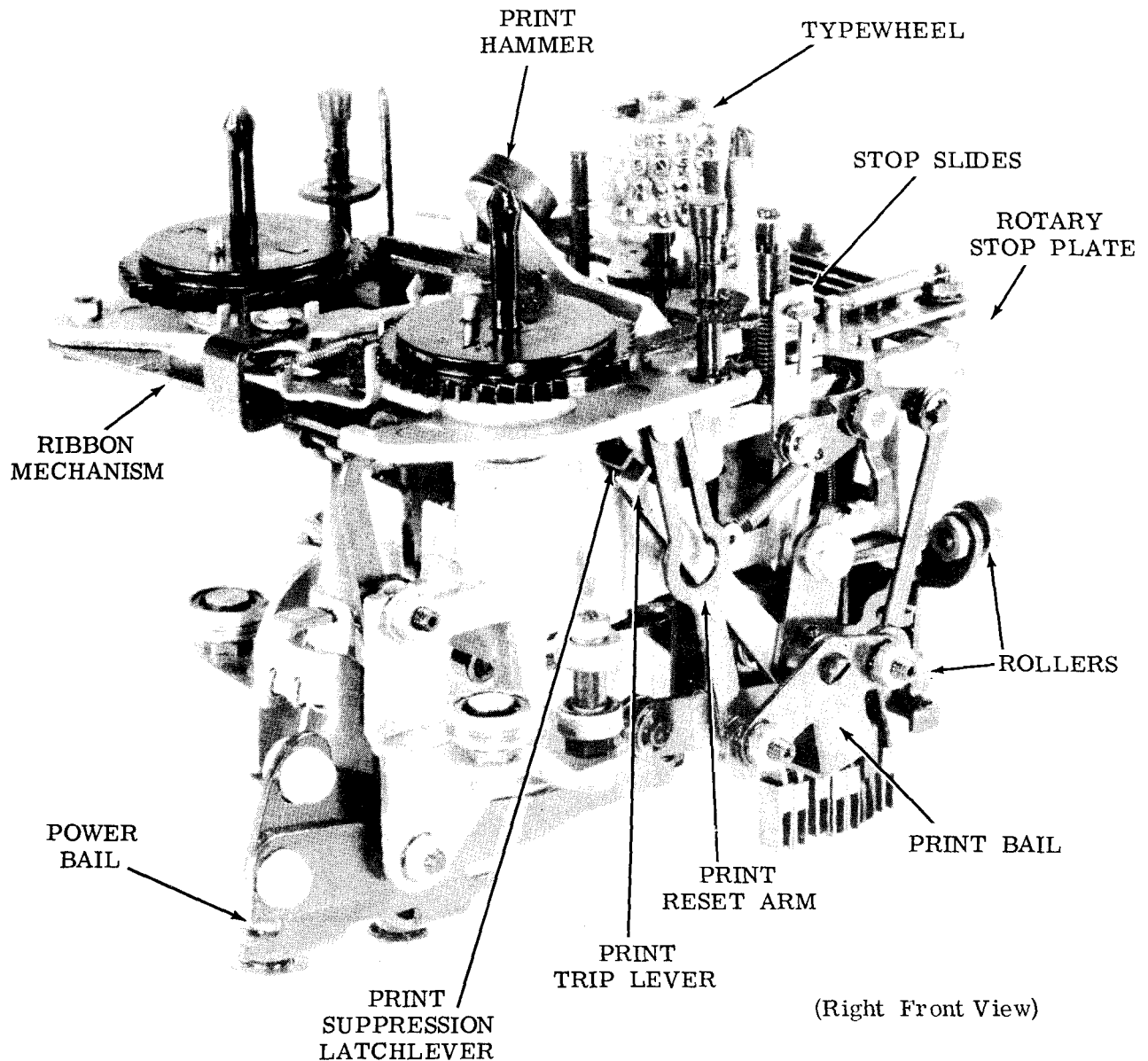

Figure 18 - Print Carriage

J. Printing

General

4.43 The printing of characters on paper is accomplished by the print carriage shown in Figure 18.

Typewheel

4.44 The characters used in printing are embossed on the cylindrical surface of a typewheel. A typewheel character arrangement

is shown in Figure 19, in which the cylindrical surface is rolled out flat. The characters are arranged in 16 vertical rows of 4 characters each. For the sake of explanation, the typewheel is divided into clockwise and counter-clockwise fields to indicate in which direction the typewheel is rotated to select the rows. The rows are then numbered 1 through 8 in each direction from the borderline between the fields. The characters in each row are designated the "1st" through the "4th" from top to bottom.

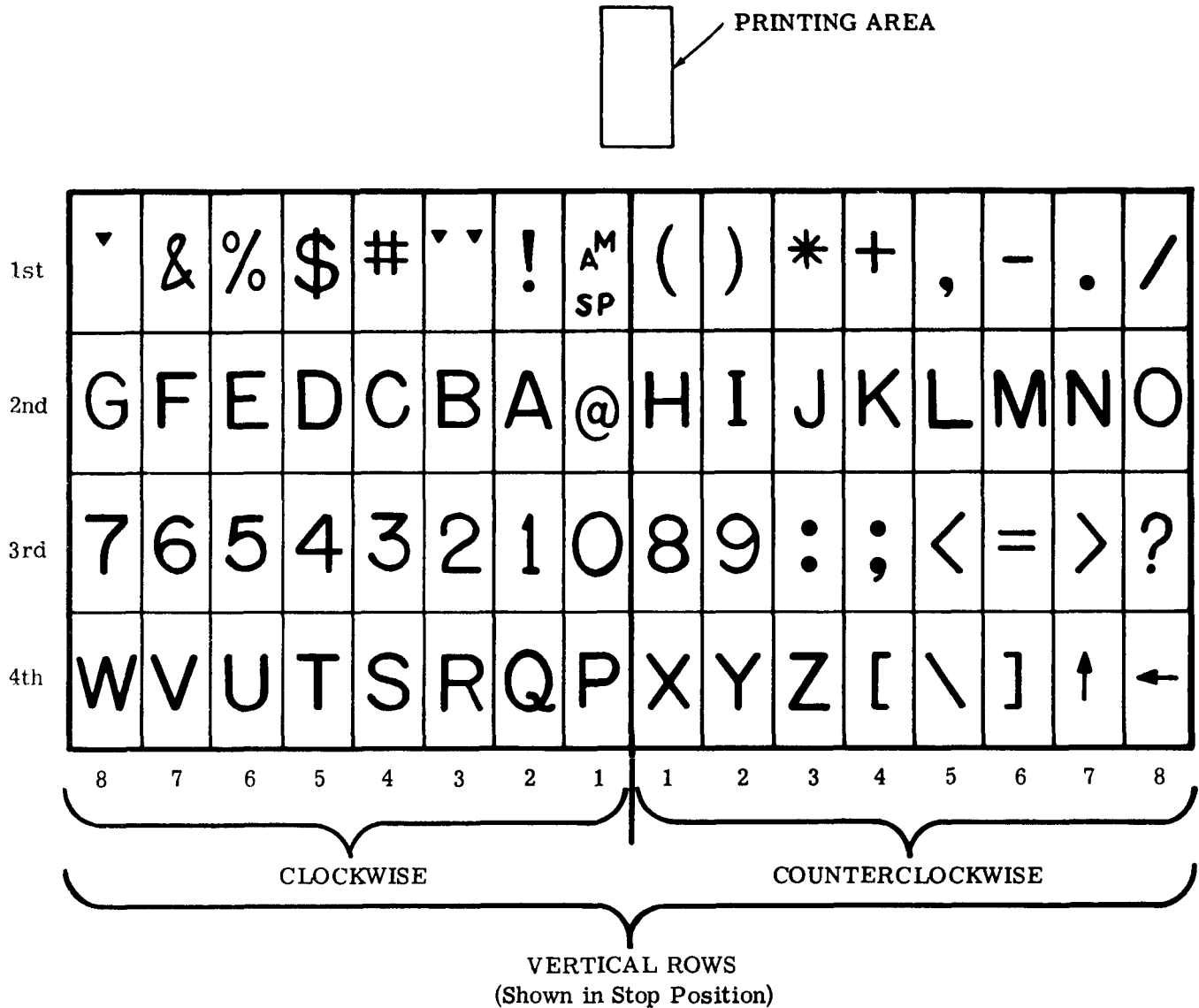

Figure 19 - Typical Typewheel Character Arrangement (As Printed)

4.45 Again for the sake of explanation, a printing area is indicated in Figure 19. This is the area the selected character must be in if it is to be printed when the print hammer strikes the typewheel against the platen. As shown in Figure 19 the borderline between the fields is under the printing area when the typing unit is in the stop condition. During the first part of each function cycle, vertical and rotary positioning mechanisms impart separate but simultaneous motions to the typewheel to select the proper character. The rotary mechanism rotates it either clockwise or counterclockwise to align the proper row with the printing area. The vertical mechanism raises it to place the proper character in the printing area. During

the latter part of the function cycle, the typewheel is returned to its stop position.

Power

4.46 As the function clutch rotates (4.36) an eccentric cam imparts oscillating motion through a carriage drive link to the carriage drive bail (Figure 5). The bail pivots rearward during the first part of the cycle and frontward to its stop position during the latter part. In doing so, it causes a power bail on the carriage to pivot first clockwise (as viewed from the left), then counterclockwise (Figure 19). The power bail has two rollers that move along the drive bail and permit it to receive the motion regardless of the carriage position along the printing line.

Rotary Positioning

4.47 The rotary positioning mechanism is illustrated in Figure 20. The direction in which the typewheel rotates from the stop position is determined by the no. 4 codebar. If the no. 4 codebar is marking the typewheel rotates counterclockwise. If it is spacing the typewheel rotates clockwise.

4.48 When a code combination is received in which the no. 4 intelligence pulse is marking, the no. 4 codebar moves up and to the left. A slide mounted on the codebar, through a linkage, pivots the rotary drive arm down. The rotary drive arm has alternate tabs at the end. With the no. 4 codebar marking and the arm pivoted down, the upper left tab engages the left rotary rack. If the no. 4 intelligence pulse is spacing, the no. 4 codebar is down, the rotary drive arm is pivoted up, and the lower right tab engages the right rack.

4.49 A rotary drive bail is held against the power bail by a spring. As these bails rock clockwise (as viewed from the left) during the first part of the function cycle, the drive arm, which is attached to the rotary drive bail, moves toward the front. If the rotary drive arm is down (marking), it pulls the left rack with it, causing a rotary pinion, a cage, a spider, a shaft, and the typewheel to rotate counterclockwise (as viewed from the top). If the rotary drive arm is up (spacing), it pulls the right rack, rotating the pinion, cage, spider, shaft, and typewheel clockwise. As the power bail and rotary drive bail rock back to their stop position during the latter part of the function cycle, two reset blocks on the drive bail return the racks and the typewheel to their stop position.

Degree of Rotation

4.50 How far the typewheel rotates in either direction is determined by the no. 1, no. 2, and no. 3 codebars.

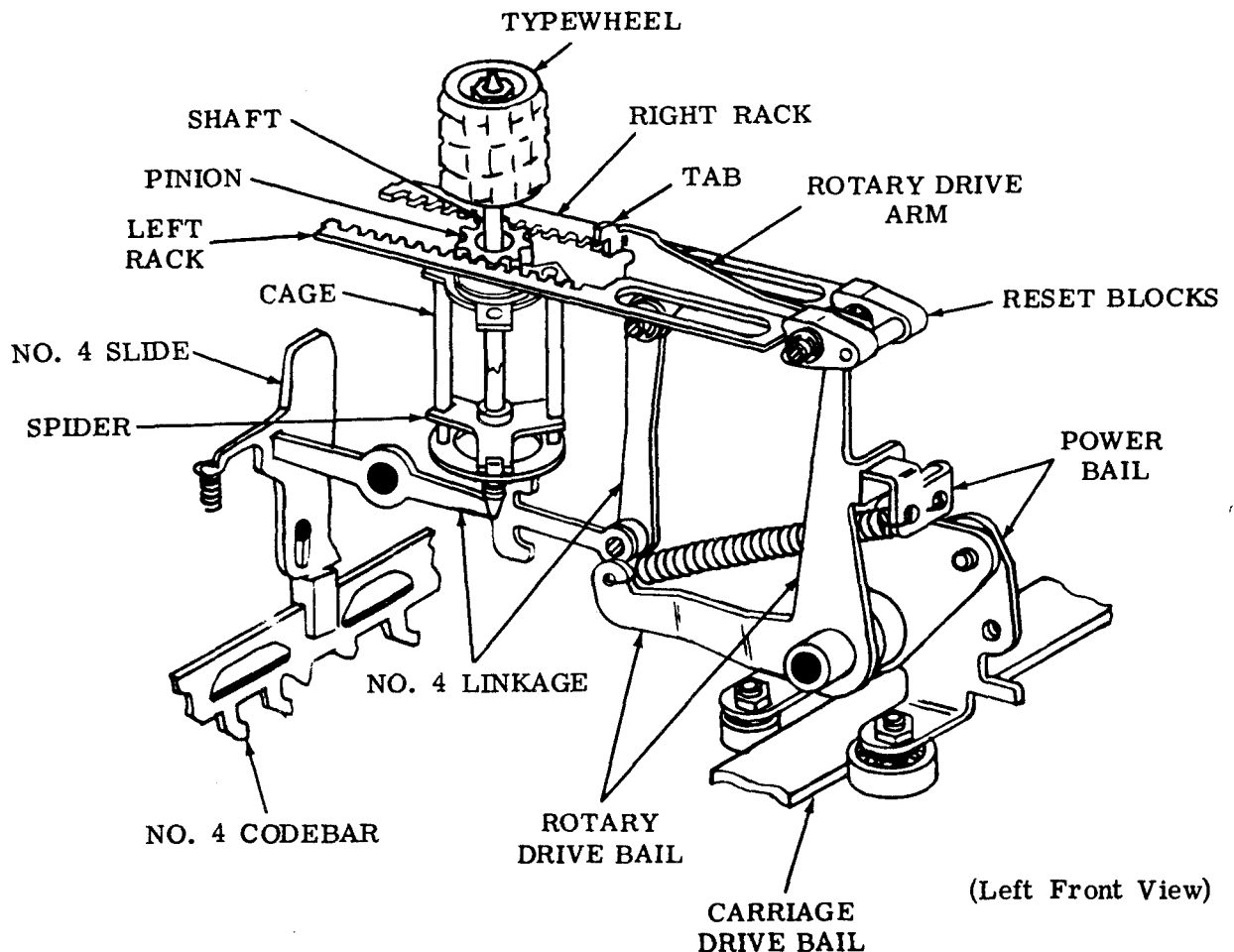

Figure 20 - Rotary Positioning Mechanism

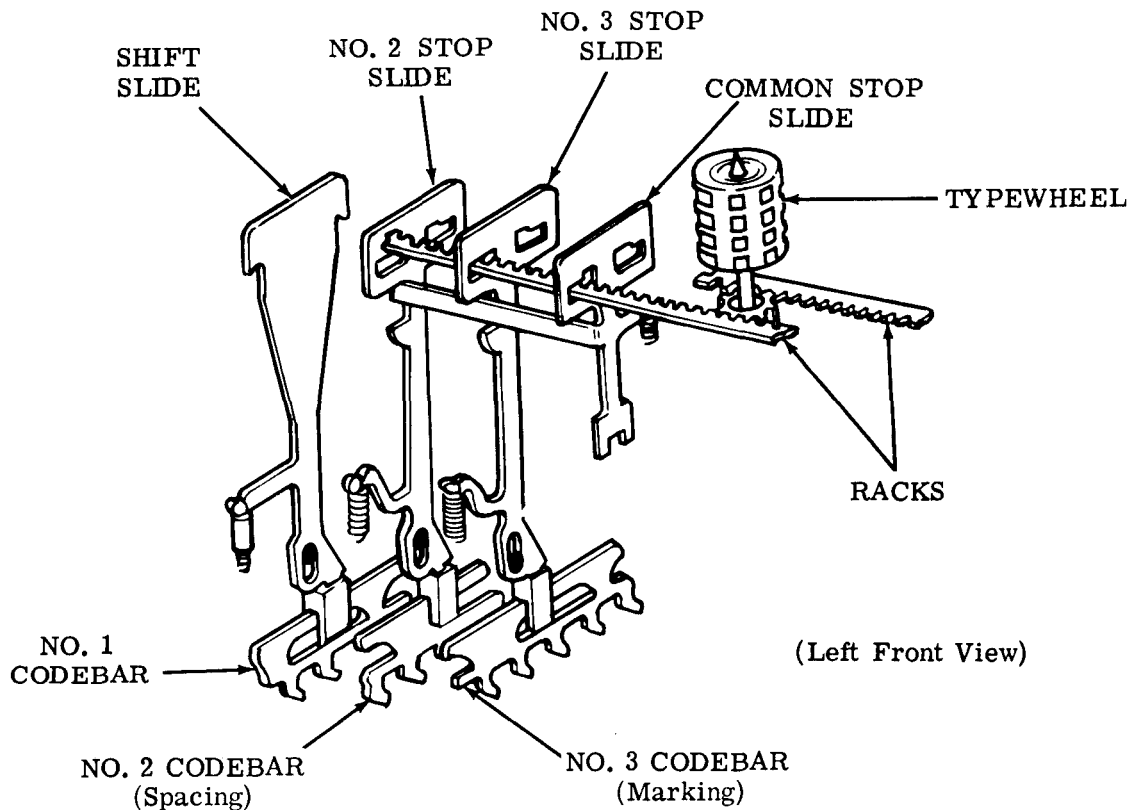

Figure 21 - Rotary Positioning Stop Slides

4.51 The no. 1 codebar controls the position of the shift slide. The no. 2 and no. 3 codebars control the positions of the no. 2, no. 3, and common stop slides. These stop slides ride the codebars and are up when the codebars are marking and down when the codebars are spacing (Figure 21).

4.52 The function of the stop slides is to stop either rack in its rearward travel. When a rack is stopped, the rotary drive bail stops, and the continuing motion of the power bail is dissipated by the spring.

4.53 The position of each stop slide determines how much the rack will travel before it is stopped. When a stop slide is down, it blocks the rack; when it is up, the rack will pass through a slot in the slide and continue to travel until blocked by another slide. The shift slide has no slot. It will block the rack whether it is up or down (Figure 21).

4.54 Depending on the position of the shift slide, the rack will travel to position either the odd or even rows of the typewheel. When the shift slide is up, the even rows are

selected; when it is down the odd rows are selected. As mentioned in 4.51, the shift slide is controlled by the no. 1 codebar.

4.55 When the no. 1 pulse is spacing, the no. 1 codebar and thus the shift slide are down. In this position the shift slide is blocked by the front stop surface of the rotary stop plate (Figure 22). The no. 2, no. 3, and common stop slides remain locked in the slots of the slide guideplate. The corresponding positions of the shift slide, the no. 2, no. 3, and common stop slide will effect 7, 5, 3, and 1 rows of typewheel rotation respectively.

4.56 When the no. 1 pulse is marking, the no. 1 codebar and thus the shift slide are up. In this position the shift slide is up, blocked by the rear stop surface of the rotary stop plate (Figure 22). The two slide guideplates, under spring tension, move to the rear. This positions all four stop slides to the rear enough to reflect one additional row of typewheel rotation. Thus the shift slide, the no. 2, no. 3, and common stop slides will effect 8, 6, 4, and 2 rows of typewheel rotation respectively.

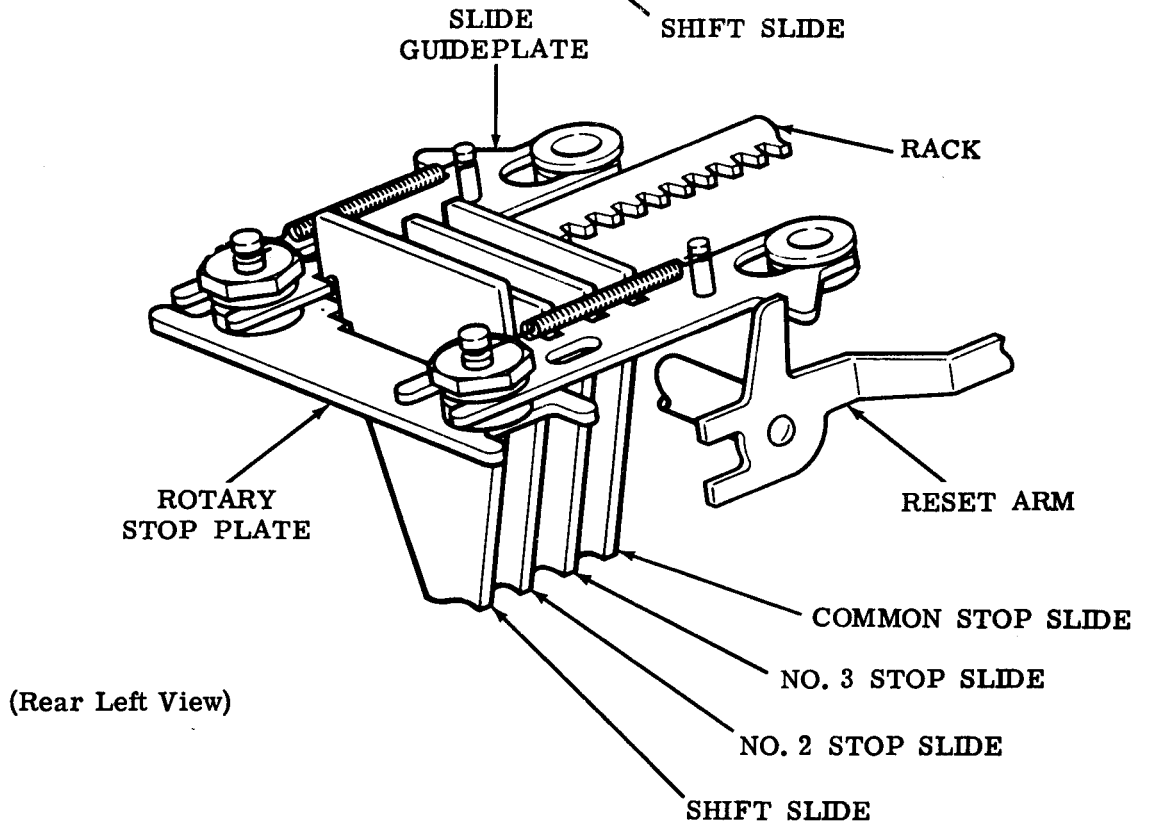
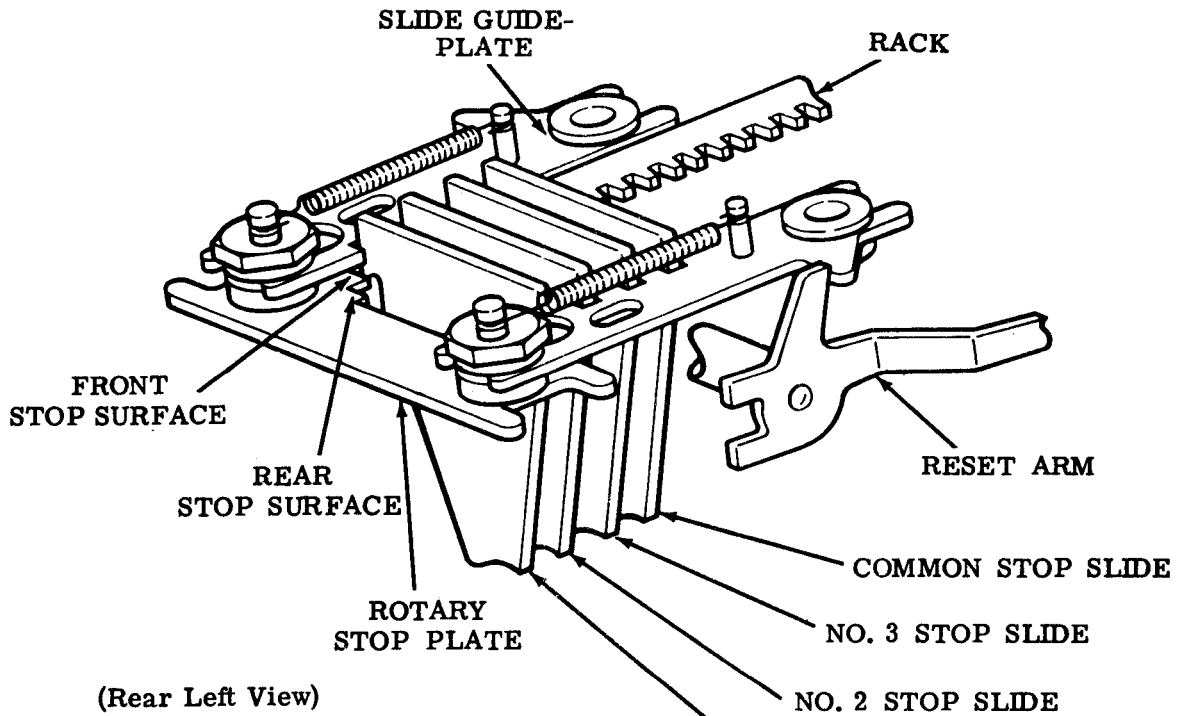

Figure 22 - Rotary Positioning Mechanism

4.57 Following is a summary of marking and spacing conditions for rotary positioning:

(a) Clockwise Field — No. 4 Pulse Spacing

Odd Rows - No. 1 Pulse Spacing

Row 1 — 2 spacing
3 spacing
common spacing } stop slides

Row 3 — 2 marking
3 spacing
common marking

Row 5 — 2 spacing
3 marking
common marking

Row 7 — 2 marking
3 marking
common marking

Even Rows - No. 1 Pulse Marking

Row 2 — 2 spacing
3 spacing
common spacing

Row 4 — 2 marking
3 spacing
common marking

Row 6 — 2 spacing
3 marking
common marking

Row 8 — 2 marking
3 marking
common marking

(b) Counterclockwise Field — No. 4 Pulse Marking

The marking and spacing conditions of the stop slides are the same as for the clockwise field.

Vertical Positioning

4.58 The vertical positioning mechanism illustrated in Figure 23 positions the typewheel so that the proper character in the selected row is in the printing area at the time of printing.

4.59 Vertical positioning is determined by the no. 5 and no. 7 codebars with their associated no. 5, no. 7, and common stop arms.

4.60 A vertical drive bail is held against the power bail by a spring. When these bails rock clockwise (as viewed from the left) during the first part of the function cycle, the vertical drive bail, through a drive arm, lifts the spider, typewheel shaft, and typewheel. How far the typewheel is raised is determined by three stop arms that are positioned in response to the no. 5 and no. 7 pulses. When the drive bail encounters an arm, it is stopped and its spring extends as the power bail continues to pivot. The spider moves up and down the bars of the cage, and thus permits rotary motion to be transferred to the typewheel regardless of its vertical position.

4.61 When a code combination is received in which the no. 5 and no. 7 pulses are spacing, the no. 5 and no. 7 codebars and their respective vertical slides remain down, spacing, and no motion is transferred to the stop arms. As the rear extension of the vertical drive bail rises, it strikes the common stop arm, which is the longest. This permits the typewheel to be raised to the point where the first character in the selected row is in the printing area at the time of printing.

4.62 When the no. 5 pulse is spacing and the no. 7 is marking, the no. 7 codebar moves its vertical slide up. The slide pivots the common and the no. 7 stop arm rearward, out of the way of the drive bail. The bail thus strikes the no. 5 arm (the second longest), and the second character in the selected row is placed in the printing area.

4.63 When the no. 5 pulse is marking and the no. 7 is spacing, the no. 5 slide pivots the no. 5 and common stop arms out of the way. The bail strikes the no. 7 stop arm (the shortest) and the third character is placed in the printing area.

4.64 When both the no. 5 and no. 7 pulses are marking, all three stop arms are pivoted out of the way. The bail moves up until it strikes the shoulder on the common stop arm, and the fourth character is placed in the printing area.

Printing Mechanism

4.65 After the typewheel has been positioned during the first half of the function cycle, the printing mechanism illustrated in Figure 24 supplies the impact which drives the selected character against the ribbon and paper. Provisions are included whereby printing is suppressed during functions.

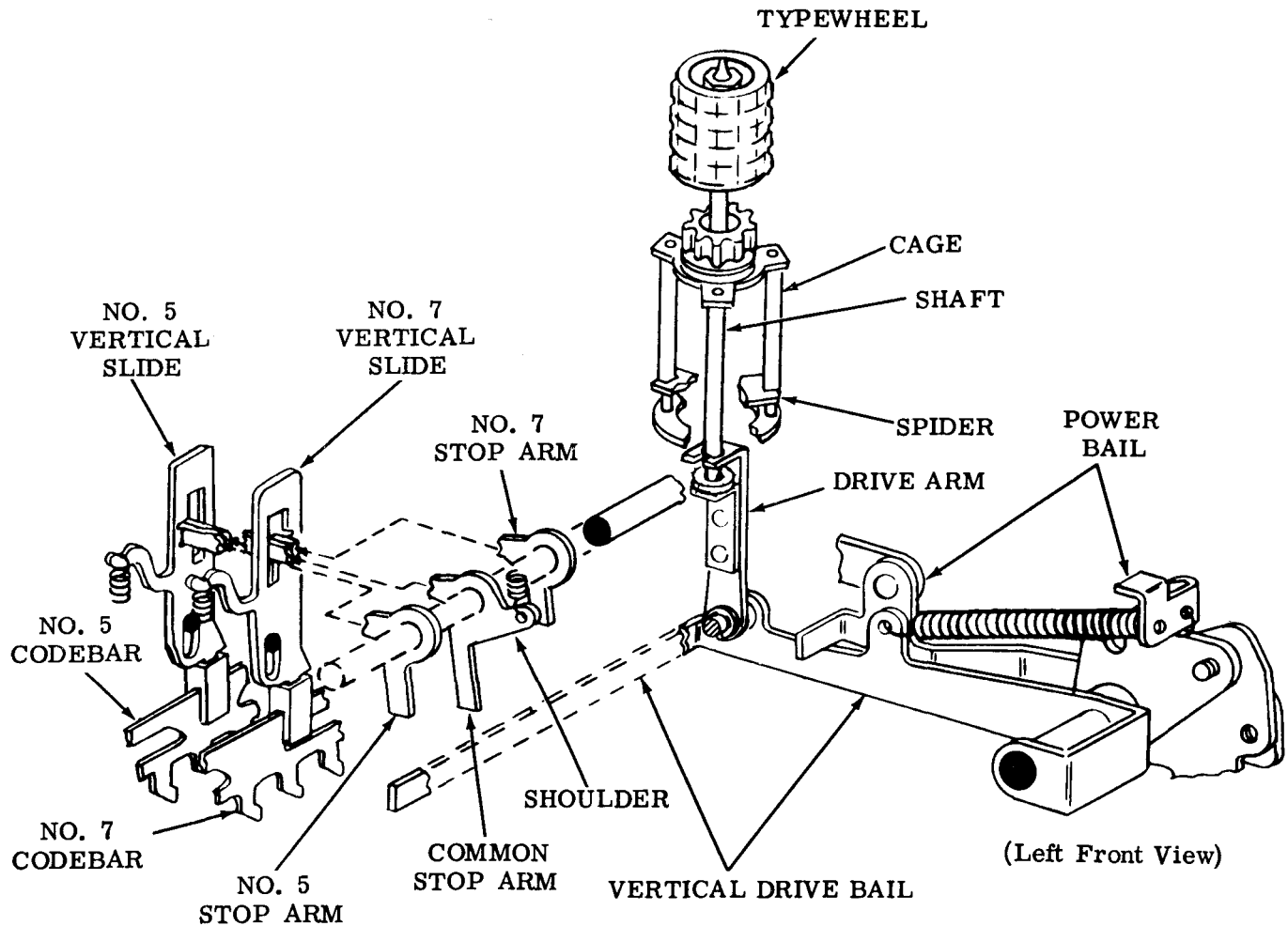

Figure 23 - Vertical Positioning Mechanism

4.66 As the power bail rocks during the first part of the function cycle, it imparts through a link clockwise motion (as viewed from the right) to a print bail. This bail, through a link and pivot shaft, pivots two reset arms. Midway in the cycle, the right arm moves a print trip lever out of engagement with a shoulder on the print hammer bail. A torsion spring snaps the hammer bail rearward, and the hammer drives the typewheel and ribbon against the paper. The lower end of the typewheel shaft pivots on the vertical drive arm and permits the wheel to be driven rearward. The hammer bail has a soft head which strikes the typewheel without damage.

4.67 During the last half of the cycle, the power bail returns the printing parts to their stop positions, and a print reset arm at-

tached to the print bail returns the print hammer bail to its stop position, where it is latched by the print trip lever.

K. Printing Suppressed

4.68 The print suppression mechanism (Figure 25) suppresses printing whenever a function code combination is received.

4.69 As the other codebars rise early in the codebar cycle, a print suppression codebar is held down by a print suppression latch. Early in the function cycle, after any of the function levers have been selected, the latch is pivoted away from the codebar by a print suppression cam on the function clutch.

4.70 If no function lever has been selected, the print suppression codebar moves up and to the left to its selected position. A print suppression slide follows the motion of this codebar and pivots a print suppression latchlever out of the way of the shoulder on the print hammer bail. Thus, when the print trip lever releases the bail, its hammer is permitted to strike the typewheel and printing occurs.

4.71 If any function lever moves up to its selected position, it engages one of a series of notches in the print suppression codebar. When the latch releases the codebar, the selected function lever prevents it from moving all the way to its selected position. Thus, the print suppression latchlever is not pivoted and catches the shoulder when the hammer bail is

released by the trip lever. The hammer does not reach the typewheel, and printing is suppressed.

4.72 As the selected function lever moves down and withdraws from the notch in the print suppression codebar, the latch, which has been returned to its stop position, engages a second latching surface on the codebar. This prevents the codebar from rising when the function lever is withdrawn, thus causing printing to occur before the print hammer is completely reset in its stop position. The print suppression codebar is completely reset with the rest of the codebars at the end of the codebar cycle, and at that time the latch engages the first latching surface.

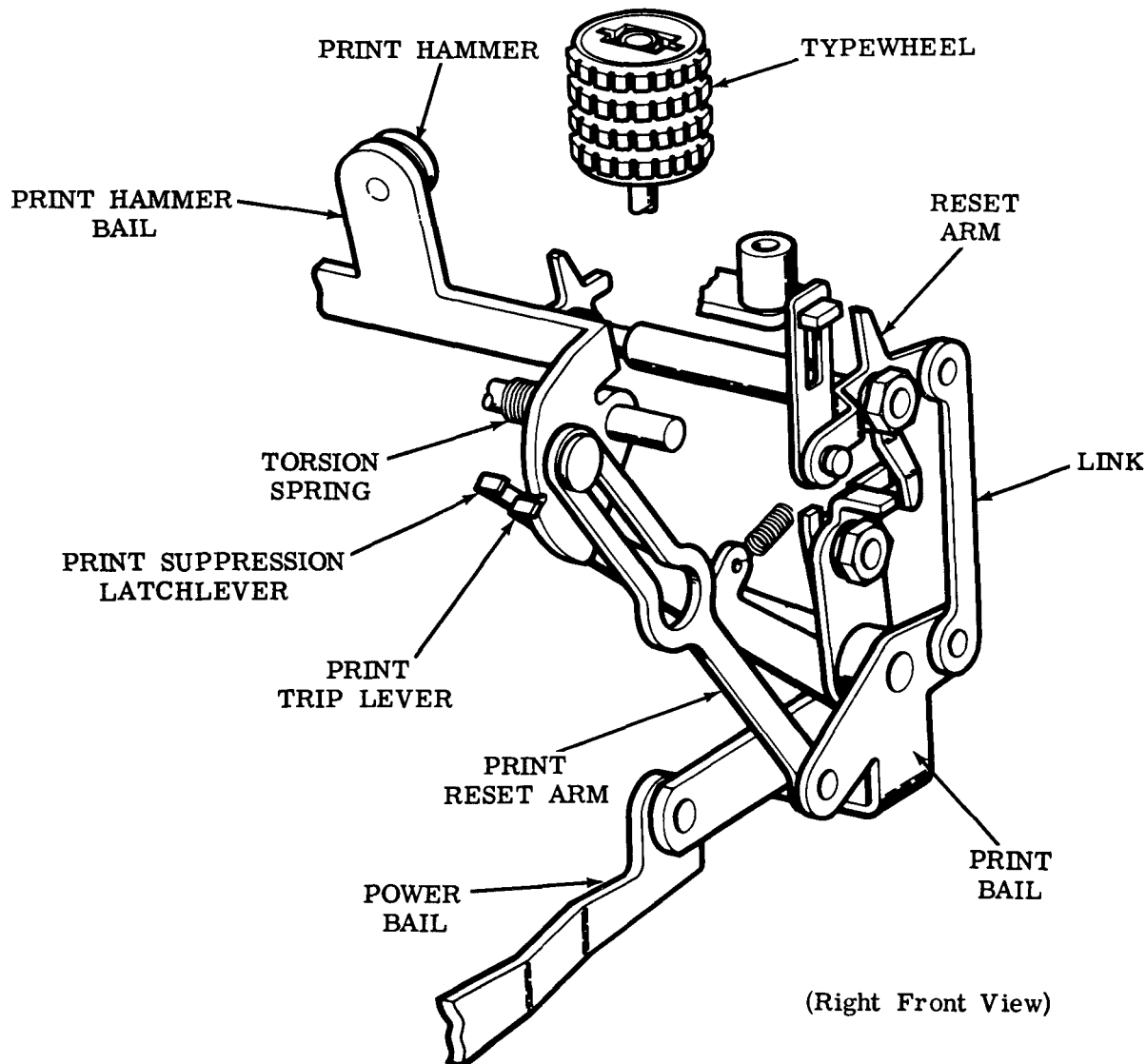

Figure 24 - Printing Mechanism

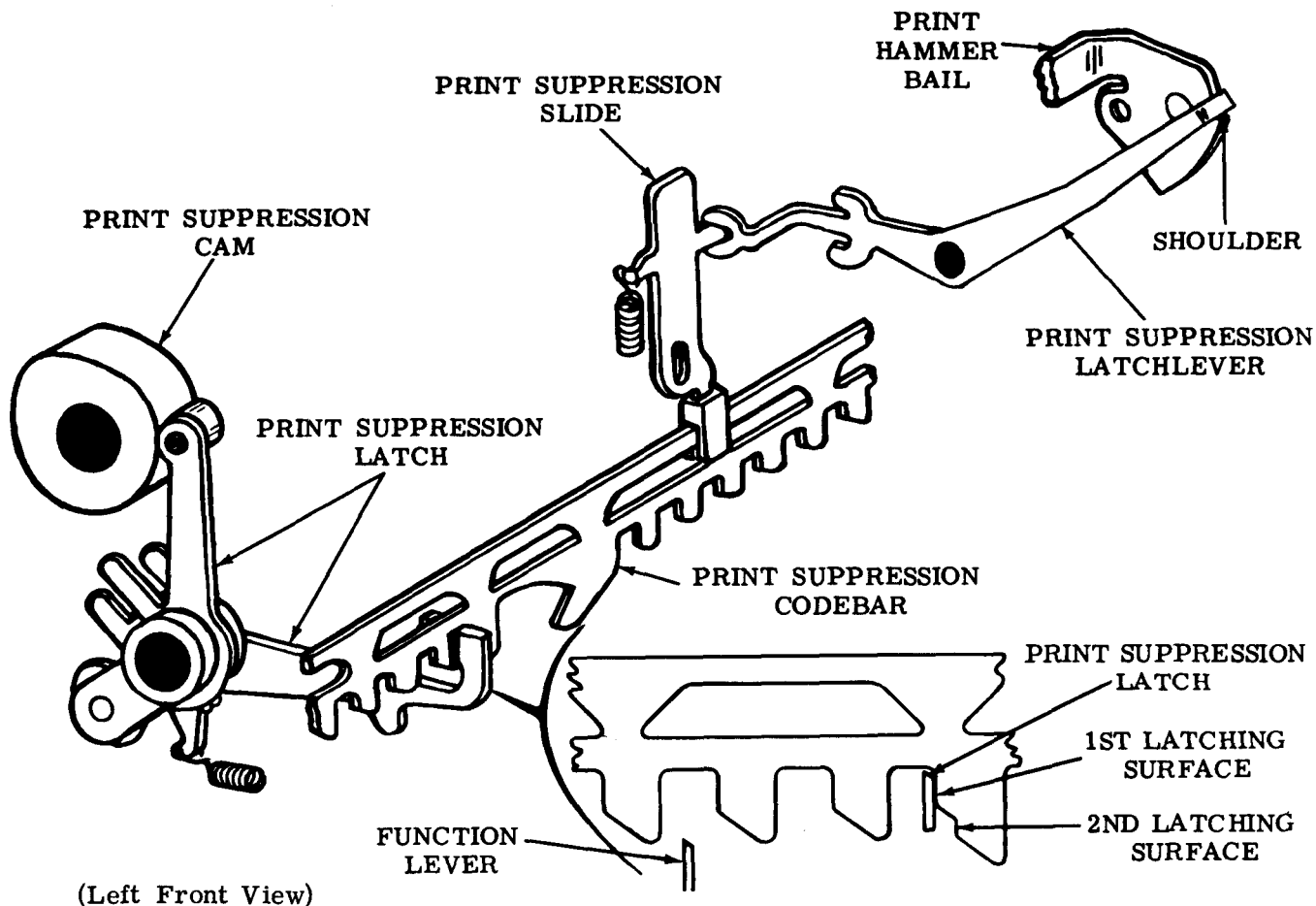

Figure 25 - Print Suppression Mechanism

L. Ribbon Mechanism

4.73 The ribbon mechanism (Figure 26) supplies the ink for printing. As the typing unit operates, the mechanism feeds the ribbon from one spool to the other, and reverses the direction of feed when the spool is nearly depleted.

4.74 As the power bail rocks during the first part of the function cycle, it pivots a ribbon power lever which moves a ribbon drive lever rearward. A feed pawl rides on the drive lever and acts on a ratchet to rotate a ribbon spool. A check pawl drops into the succeeding tooth and detents the ratchet until it is again rotated during the next operation.

4.75 The mechanism continues to rotate one spool until the other is nearly depleted. An eyelet in the ribbon then engages the ribbon reversing arm. As the eyelet is pulled against the arm, the latter moves to a point where a detent spring shifts it to its alternate position,

where one of its reversing extensions falls ahead of an extension on the feed pawl. As the pawl moves frontward during the last half of the cycle, it strikes the arm extension and is pivoted to its alternate position against the other ratchet. In doing so, it strikes an extension on the check pawl and pivots it to its alternate position against the other ratchet. The depleted spool is now rotated to take up the ribbon until the other spool is nearly depleted, when reversal again takes place.

4.76 The ribbon guide, which is spring biased upward is mounted so that it will slide up and down on posts. As the print pivot shaft turns during the first half of the cycle, the two pivot arms permit the guide to rise so that it is between the selected character and the paper midway in the cycle. At this time the print hammer drives the typewheel and the ribbon against the paper. During the last half of the cycle, the pivot arms retract the guide and ribbon to their stop position so that the printed characters are visible.

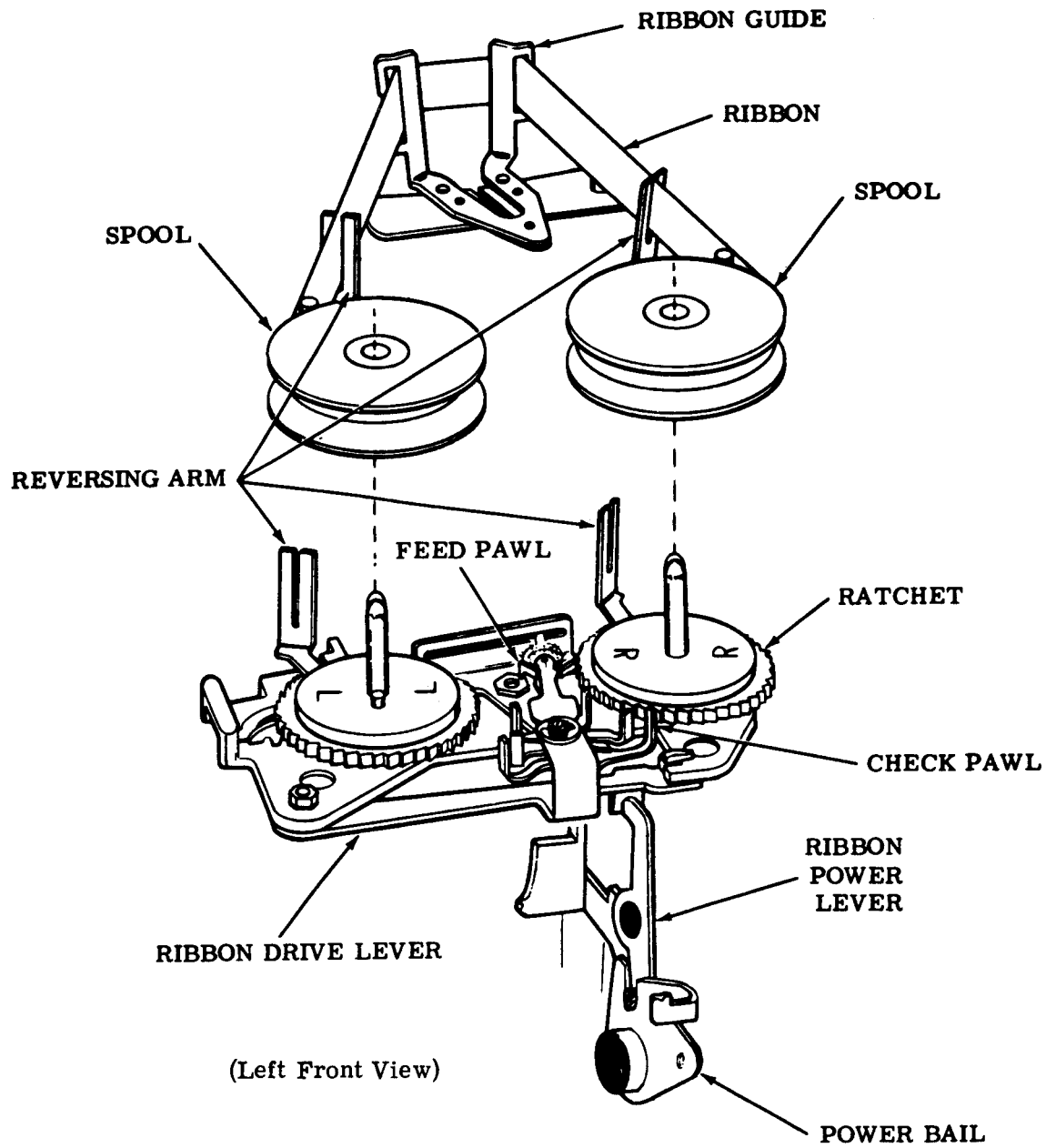

Figure 26 - Ribbon Mechanism

M. Spacing Mechanism

4.77 The spacing mechanism (Figure 27) positions the carriage so that the printed characters are horizontally in line on the paper. Each time a character is printed, the carriage is positioned one character to the right. Spacing is suppressed on all functions except "space" when spacing occurs and printing is suppressed. At the end of the printed line, spacing is sup-

pressed and the typing unit overprints. When the "carriage return" function is received, the carriage is returned to the left margin.

Note: With the automatic carriage return-line feed feature, spacing is not suppressed at the end of a line. Also, the typing unit does not overprint at the end of a line. The carriage is returned automatically to the left margin when it reaches a predetermined point.

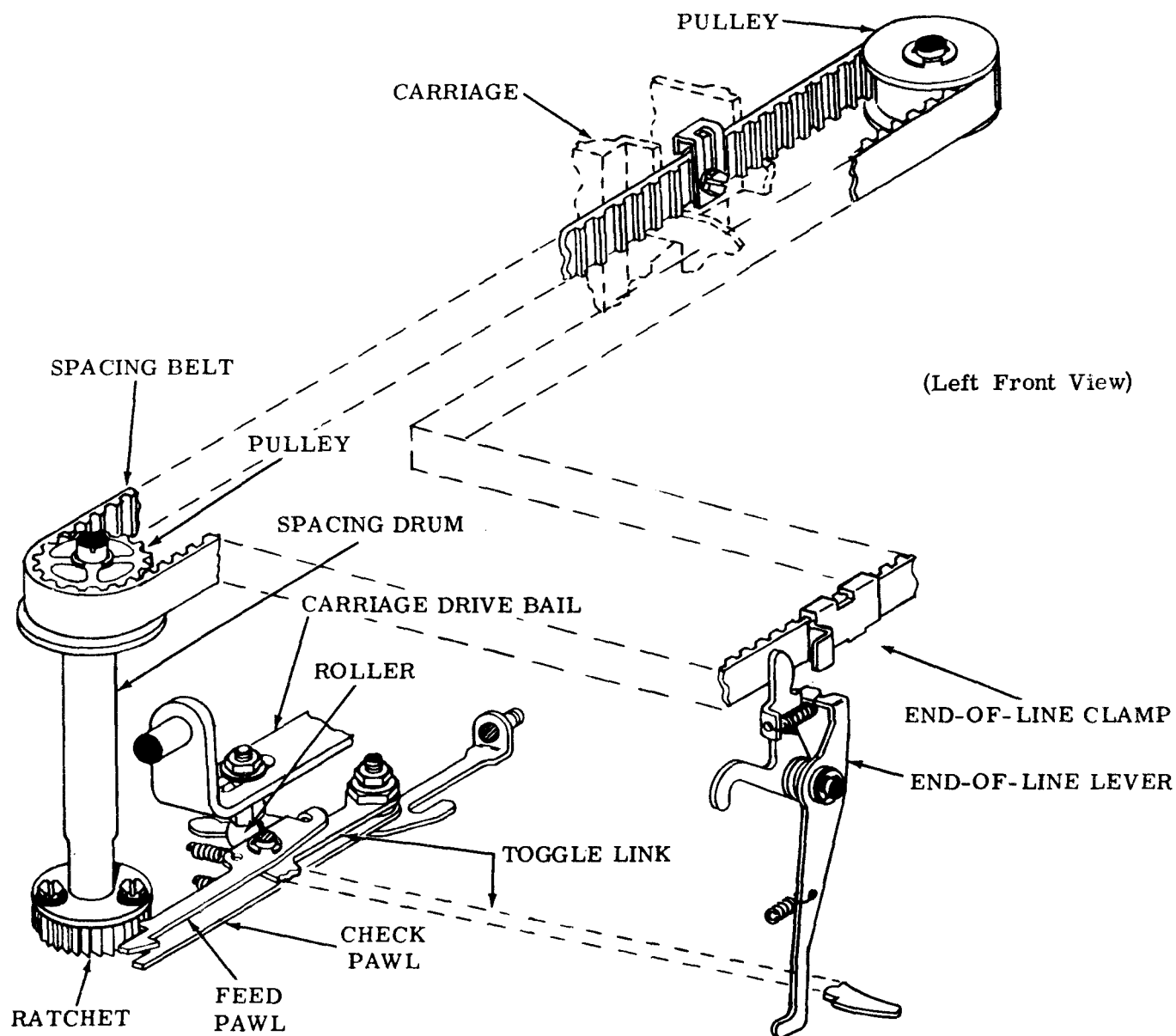

Figure 27 - Spacing Mechanism

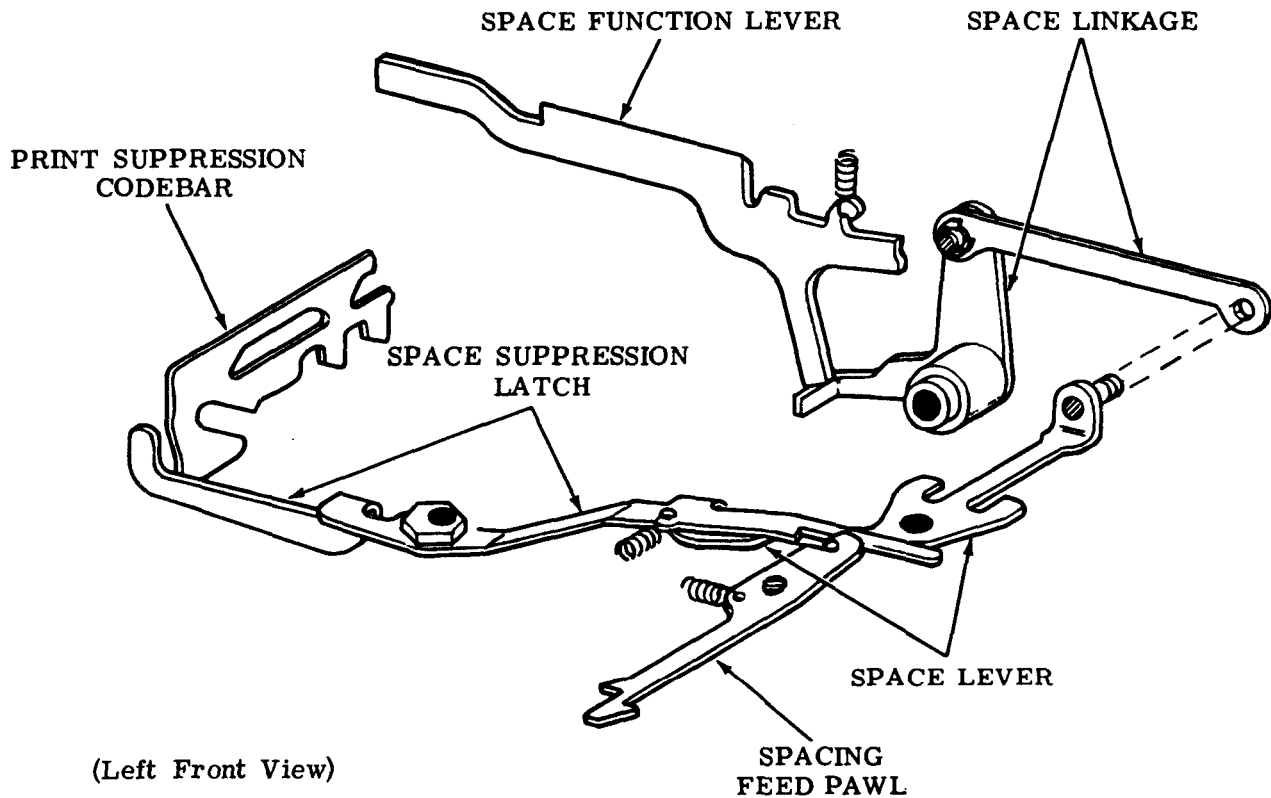

Figure 28 - Space Function and Space Suppression Mechanism

4.78 As the carriage drive bail moves rearward during the first part of the function cycle, a small roller mounted near the left end permits a toggle linkage consisting of a spacing feed pawl and toggle link to buckle rearward under spring tension. The feed pawl moves to the right and engages the next tooth on the ratchet. The ratchet is part of the spacing drum. When the roller moves towards the front during the other part of the cycle, it unbuckles the toggle linkage, and the pawl is moved to the left and rotates the drum one tooth. This motion is imparted by a pulley at the top of the drum to a spacing belt which is looped around a pulley on the right side of the typing unit. The spacing belt in turn moves the carriage to the right one space against the tension of a large carriage return spring. The carriage is held in this position by a check pawl, which engages the spacing drum ratchet.

4.79 When the "space" code combination is received, the codebars permit the space function lever to move up to its selected position early in the function cycle. This motion is transferred, through a space linkage, to a space lever which moves the print suppression latch

out of the way of the toggle linkage. The spacing linkage buckles completely and spacing takes place as described. Printing is suppressed as described in 4.68.

N. Space Suppression Mechanism

4.80 On Functions: On every function except "space," spacing as well as printing must be suppressed (Figure 28). When a character to be printed is received, the print suppression codebar moves up and to the left. In doing so it pivots a space suppression latch so that it is moved to the right, out of the way of the toggle linkage. This permits the linkage to buckle and effect spacing.

4.81 On the other hand, when a function is received, the print suppression codebar remains down and to the right, and does not pivot the space suppression latch. In this position, the space suppression latch engages the toggle linkage and prevents it from buckling all the way, and the feed pawl does not move far enough to engage the next tooth. Thus the spacing drum is not rotated, and the carriage is not spaced.

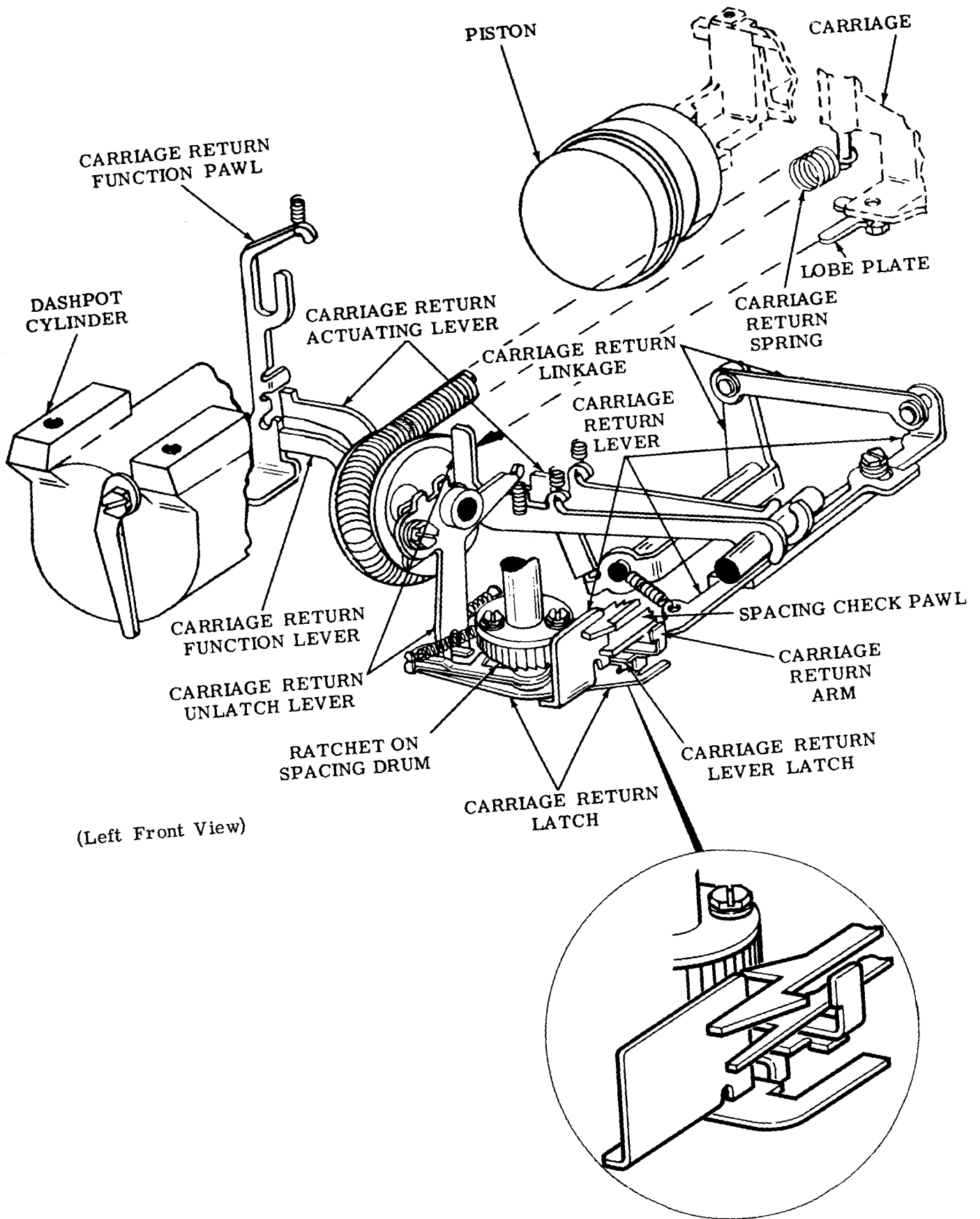

Figure 29 - Carriage Return Mechanism

4.82 At End-of-Line: When the carriage reaches the right margin, a clamp on the spacing belt pivots an end-of-line lever counterclockwise. In this position, a latching surface on the spacing toggle link engages the end-of-line lever and prevents the linkage from buckling and effecting spacing. Thus, spacing is suppressed, and the typing unit overprints at the right margin until the "carriage return" code combination is received.

Note: With the automatic carriage return-line feed feature, spacing is not suppressed at the end of a line. Also, the typing unit does not overprint at the end of a line. The carriage is returned automatically to the left margin when it reaches a predetermined point.

O. Carriage Return Mechanism

4.83 The carriage return mechanism is illustrated in Figure 29.

4.84 When the "carriage return" code combination is received, the carriage return function lever moves up to its selected position, and engages the carriage return function pawl. As the function bail moves the lever and pawl down during the middle portion of the cycle, an extension on the pawl drives the carriage return actuating lever down also. This motion is transferred by means of linkages to the carriage return lever. In moving forward the carriage return lever is latched by both the carriage return latchlever and carriage return latch.

4.85 In moving forward the carriage return lever also disengages the spacing pawl and check pawl from the spacing drum ratchet. The carriage return spring then pulls the carriage back to the left margin. As the carriage nears the left margin, a lobe plate on the carriage strikes the unlatch lever. This unlatches the carriage return lever and the carriage return latch. However the carriage return lever remains engaged by the latchlever and cannot move to the rear to allow the pawls to engage. When a code combination is received in which spacing is not suppressed, the carriage return lever allows the feed and check pawls to again engage the ratchet. This is accomplished by the feed pawl moving to the right and back to unlatch the carriage return arm and latchlever from the carriage return lever. The latter, under spring tension, moves toward the rear of

the unit allowing the pawls to engage the ratchet. Late in the function cycle the carriage return function pawl is stripped from its function lever by the stripper bail.

4.86 As the carriage approaches the left margin at relatively high speed, a piston on the carriage enters a dashpot cylinder and compresses the air ahead of it. The air forms a cushion which slows the carriage and then, as it escapes through a small, variable hole at the left end of the cylinder, permits the carriage to be stopped at the left margin without excessive shock.

P. Paper or Form Feeding

4.87 The paper feed mechanism used on friction feed typing units is illustrated in Figure 30.

4.88 The paper feed mechanism vertically positions the paper so that the printed characters are properly located in lines on the paper. It feeds the paper on receipt of the "line feed" code combination. It may be adjusted for either single or double line feed.

4.89 The paper feeds off a roll and is led around a platen that vertically positions it in front of the typewheel. A paper guideplate leads it down around the platen. A pressure roller, which sits in a cutout in the guide, holds the paper against the platen so that it feeds when the platen rotates. A curved wire shaft biases the pressure roller and the guideplate against the paper. The pressure is released by a lever on the right end of the shaft. The paper is held around the front of the platen by a wire guide and is led up out of the typing unit by a deflector guide. It can be manually fed by a knob on the left end of the platen.

4.90 When the "line feed" code combination is received, the codebars permit the line feed function lever to move up to its selected position early in the function cycle. The function lever, in turn, moves up a line feed blocking lever to engage the latching surface of a line feed drive link. As the left drive arm on the function rocker shaft moves down, a line feed arm engages the blocking lever and moves it down. This motion is transferred, through a line feed linkage, to a pawl which engages a ratchet on the left end of the platen. The pawl rotates the platen which feeds the paper up one or two lines depending on how the mechanism is adjusted.

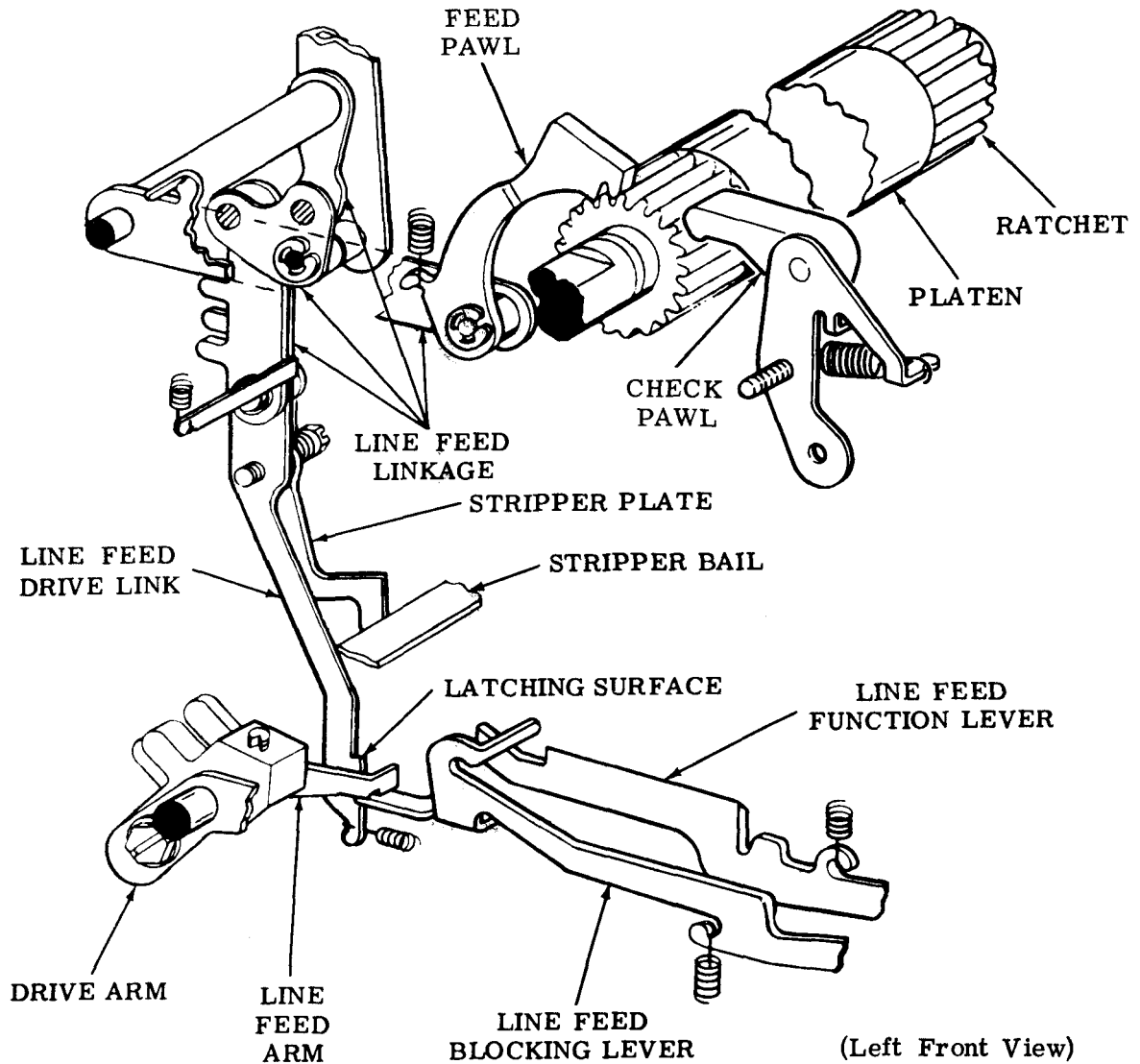

Figure 30 - Paper Feed Mechanism (Friction Feed)

4.91 The feed pawl is guided into the teeth of the platen ratchet by two posts. A check pawl riding on the ratchet at the left side of the platen holds the platen firmly until the platen is again rotated. At the end of the cycle, the function stripper bail contacts a stripper plate and strips the drive link from the blocking lever.

Q. Sprocket Feed Typing Units

4.92 The platen drive mechanism (Figure 32) rotates the platen for vertical positioning so that the printed characters are properly located in lines on the forms. The platen drive mechanism is activated through the form-out and form-feed mechanisms (Figures 31 and 33),

and controlled by the form-feed clutch. It feeds forms upon receipt of either the "line feed" or "form out" code combination and may be adjusted for single or double line feed.

4.93 Forms feed from a conveniently located stack of forms. They feed under a paper roll spindle and, if used, a low-paper arm and a paper-out arm. From here, the forms, led by a paper guideplate, engage sprocket pins and advance between the platen and two paper guides until vertically positioned in front of the type-wheel. The two paper guides and a wire guide hold the forms to the front of the platen and insure that the forms advance around the platen while moving up and out of the typing unit. As the forms move out of the typing unit, they go

over the paper roll spindle, which separates incoming from outgoing forms.

Note: Forms can be manually fed by depressing the center knob and rotating the platen knob located on the left end of the platen.

4.94 Form Feed: When the typing unit receives the "line feed" code combination, the line feed function lever (Figure 31) moves up to engage the line feed function pawl in slot

no. 13. The function pawl, by means of a lug, connects with the line feed strip pawl in the adjacent slot on the function casting (slot M). During the function cycle the function pawl engages and pulls down the strip pawl. The strip pawl pivots the line feed lever. An extension on the line feed lever contacts the trip lever extension which pivots the clutch trip lever away from the shoe lever on the form feed clutch. The clutch engages and the typing unit advances the form for single or double line feed by means of the platen drive mechanism.

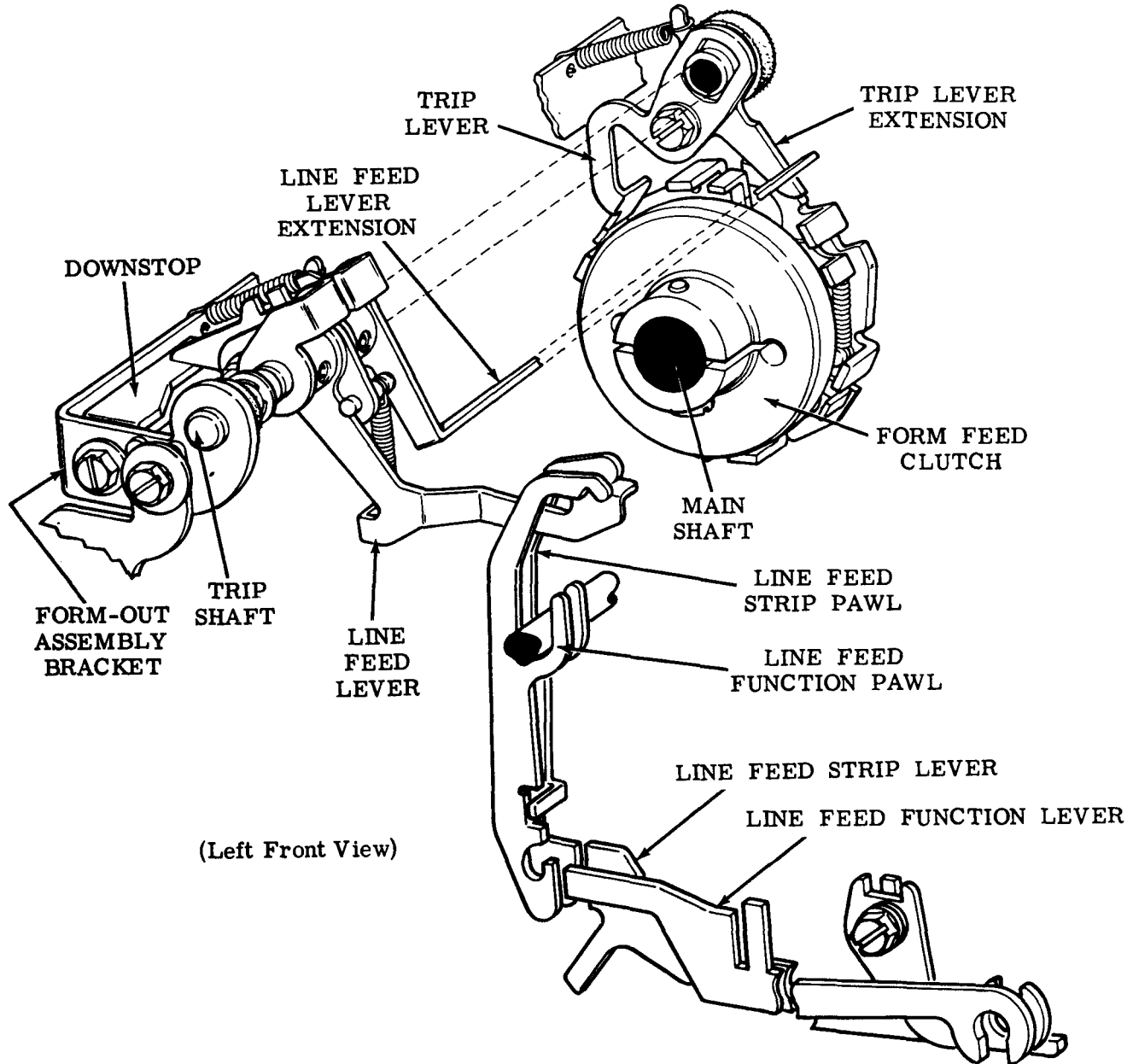
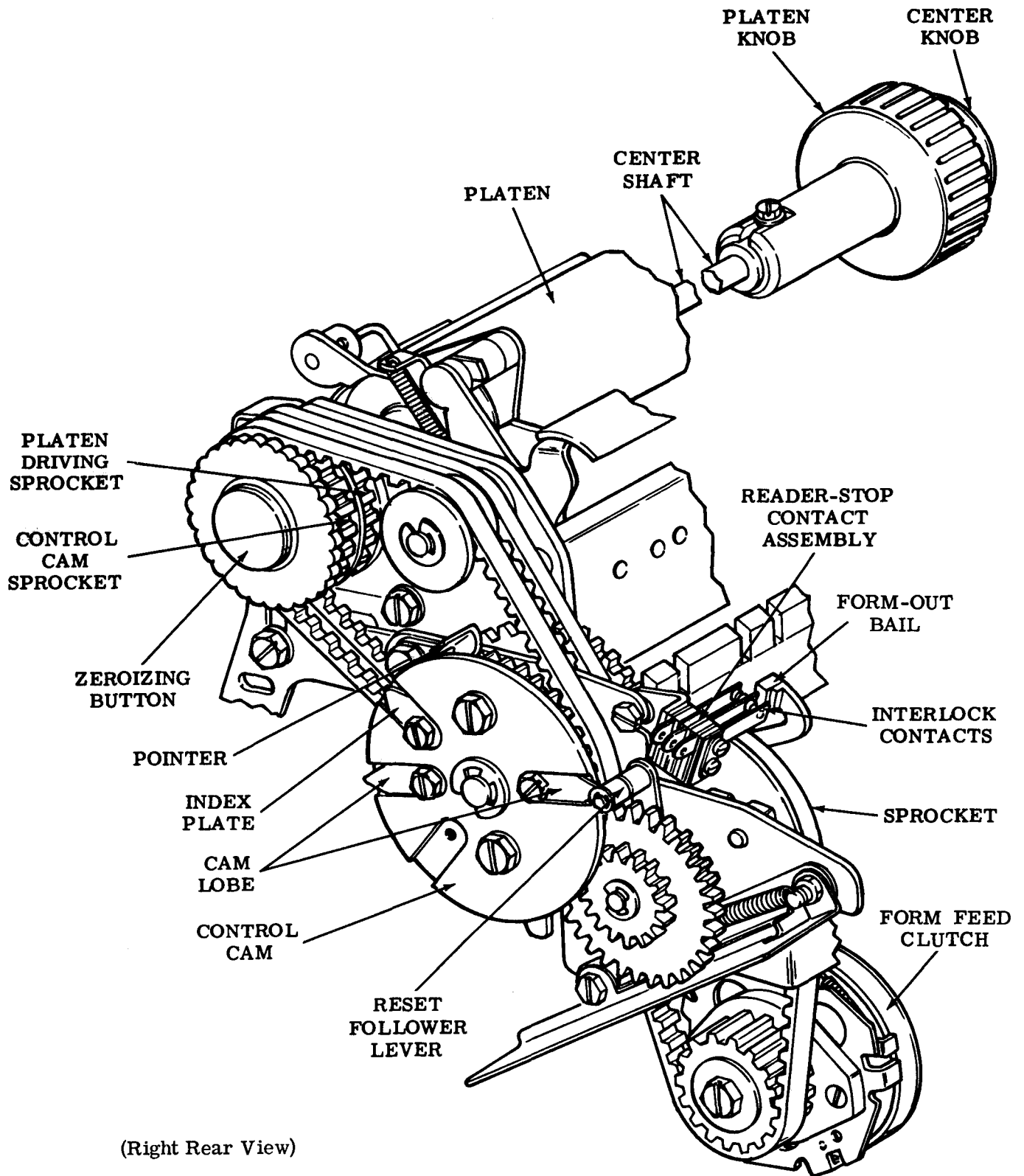

Figure 31 - Form-Feed Mechanism (Sprocket Feed)



(Right Rear View)

Figure 32 - Platen Drive Mechanism (Sprocket Feed)

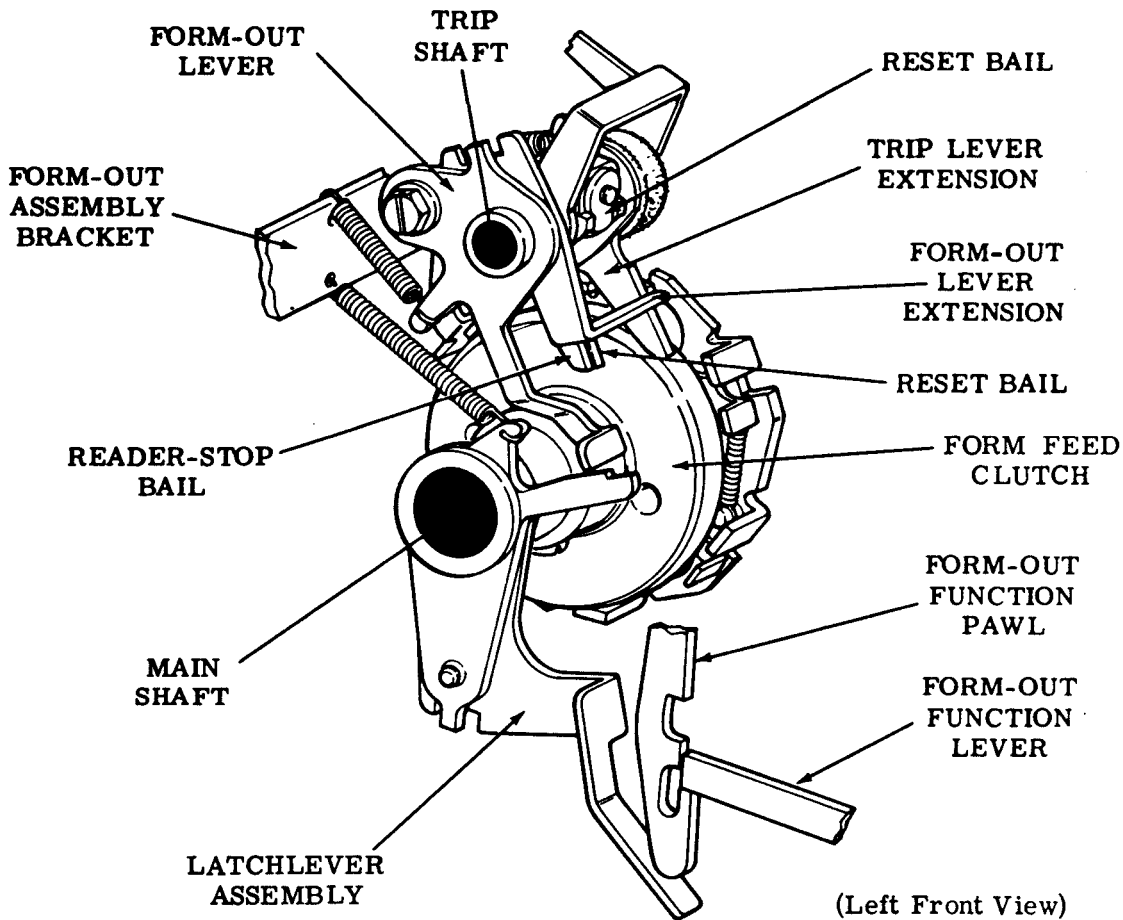

Figure 33 - Form-Out Mechanism (Sprocket Feed)

4.95 Late in the function cycle the strip pawl strikes the tail of the line feed strip lever and moves to the rear. The lug on the strip pawl moves the function pawl to the rear, disengaging it from the function lever. Due to spring tension the line feed lever and its extension return to their front position. The trip lever strikes the clutch shoe lever and the clutch is disengaged.

4.96 The number of lines the form advances depends on how much the clutch rotates before it is disengaged. If the clutch becomes disengaged at the first shoe lever, the form will advance one line; if the clutch becomes disengaged at the second shoe lever, the form will advance two lines; and so on. The amount of clutch rotation depends on how soon the strip pawl comes in contact with the line feed lever. This time will depend upon the distance between the strip pawl and the line feed lever. When the distance is small the clutch will trip and engage sooner, rotating a greater amount before it is disengaged. Double line feed will result. If the

distance is greater the clutch will trip and engage later, rotating a smaller amount before it is latched. Single line feed will result.

4.97 Form-Out: When the typing unit receives the "form out" code combination, the form-out function lever (Figure 33) moves up to engage the form out function pawl in slot no. 14. During the function cycle the pawl is pulled down. This action pivots the latchlever assembly which becomes disengaged from the form-out lever. Due to spring tension the form-out lever pivots to the rear. An extension on the form-out lever pivots the trip lever extension which in turn moves the clutch trip lever away from the clutch shoe lever. The form feed lever engages and remains engaged throughout the form-out cycle.

4.98 When engaged the clutch drives the platen drive mechanism which consists of belts, gears, and sprockets. The platen drive mechanism is illustrated in Figure 32.

4.99 As long as the form-out lever stays pulled to the rear by spring tension, the form will advance except as regulated by the control cam of the platen drive mechanism. Whenever the platen rotates, the control cam, being related to the platen by belts and gears, also rotates. The rotating cam, through cam lobes, a reset follower lever, and a reset bail initiates the action to terminate the advance of the platen and thus the form-out cycle.

4.100 When a cam lobe contacts the reset follower lever and rotates it toward the rear, a reset bail also rotates and pivots the form-out lever extension away from the trip lever extension. The trip lever engages a shoe lever and disengages the clutch, terminating form-out.

4.101 With the form-out just terminated the reset follower lever remains on the high part of a cam lobe, and the form-out lever is blocked by the reset bail from rotating to its latched position. When a "form feed" code combination is received, however, the control cam rotates and the reset follower lever moves from the high part of the cam lobe. This causes the reset bail to rotate downward and move away from the form-out lever extension. As a result, the form-out lever is permitted to latch. The typing unit can now receive another "form-out" command.

Note: It is in order to allow the cam lobe to clear the reset follower lever that a "form feed" command is given before another form-out cycle can begin.

4.102 The gearing on the platen drive mechanism varies to accommodate various size forms.

4.103 When the platen drive mechanism advances the form one or two lines during "form feed" the cam lobe rotates an equivalent distance. Then, when "form-out" is received the rest of the form will be advanced with the cam lobe merely rotating until it strikes the reset follower lever.

4.104 The control cam can have three lobes with the result that the form may be advanced one-third the distance for which the gears were installed. For example, if the gears on the platen drive mechanism were designed to advance a form of a certain length, by installing cam lobes, this length can be varied to smaller lengths.

4.105 When an Automatic Send-Receive Teletypewriter Set receives a "form-out" code combination, the form-out bail (Figure 32) is rotated toward the front by the form-out lever extension. This action causes the interlock contacts of the reader stop contact assembly to be operated with the following results:

(a) A pair of normally closed contacts are opened during the "form-out" function. This stops the tape reader from transmitting and prevents characters "on the fly" from being printed.

(b) A pair of normally open contacts are closed. This keeps the typing unit motor operating in case the typing unit is turned off before the form-out cycle is completed. Thus, synchronization of the forms is maintained.

4.106 The form can be manually advanced any length by pressing the zeroizing button on the platen (Figure 32). This will disengage the platen from the platen drive sprocket and allow it to rotate freely.

R. Margin Bell and End of Line Bell ←

4.107 Margin Bell: As the carriage moves to the right during printing, the carriage upper rear roller makes contact with and depresses a latch which is secured to a lever mounted on the rear rail. As the latch is depressed, the lever is rotated and moves the automatic carriage return-line feed codebar to the right a short distance, where a notch in the codebar permits the bell function lever to move up to its selected position, where it is latched by its function pawl. During the middle portion of the function cycle, the lever moves the pawl down against the pressure of the latter spring. When the stripper bail strips the pawl late in the function cycle, the pawl moves up and causes a clapper mounted on a wire spring to snap up and ring a gong. ←

4.108 End of Line Bell: End of line bell operation proceeds in the same manner as above, except that a projection on the carriage picks up the automatic carriage return-line feed codebar at a predetermined point and moves the codebar to the right a short distance until a notch in the codebar permits the bell function lever to move up to its selected position. ←

Automatic Carriage Return-Line Feed (Friction Feed)

4.109 As described for the end of line bell (4.108), the carriage picks up the automatic carriage return-line feed codebar at a predetermined point and moves it to the right. When the carriage reaches the right margin, a notch in the codebar permits an automatic carriage return-line feed function lever to move up to its selected position, where it is latched by its function pawl.

4.110 The automatic carriage return-line feed function lever, in turn, moves the line feed blocking lever up to where it is latched by the line feed link. Line feed then occurs as described in 4.87 through 4.91 and 4.94 through 4.96.

4.111 When the automatic carriage return-line feed function lever and its function pawl are pulled down during the middle portion of the cycle, the pawl encounters an extension on the carriage return function pawl and moves it down. Carriage return then occurs as described in 4.83 through 4.86.

Automatic Carriage Return-Line Feed (Sprocket Feed) (Figure 34)

4.112 Automatic carriage return-line feed in 3300 Series Coded Sets' sprocket feed typing units involves the action of the automatic codebar. The automatic codebar has projections on the right which can be removed to vary the line length and return the carriage on the 69th or 72nd character. The automatic codebar also has two slots on the underside, one associated with the automatic carriage return function lever and one towards the right associated with the automatic line feed function lever.

4.113 As the carriage approaches the right margin the carriage strikes the projection of the automatic codebar, moving it to the right. This allows both the automatic carriage return function lever and the automatic line feed function lever to move up.

4.114 As the automatic carriage return function lever moves up it engages its associated function pawl and carriage return proceeds as described in 4.84 thru 4.86. As the automatic line feed function lever moves up it engages its associated function pawl. As the automatic line feed function pawl moves downward it drives the

line feed strip pawl downward by means of the extension on the line feed strip pawl. An extension on the line feed lever controls the trip lever extension which pivots the clutch trip lever away from the shoe lever on the form feed clutch. The downward movement of the line feed strip pawl drives the line feed lever downward, tripping the form feed clutch. The clutch engages and the typing unit advances the form for single or double line feed. Near the end of the function cycle the line feed strip pawl strikes the projection of the line feed strip lever and moves towards the rear. Moving rearward the extension moves the automatic line feed function pawl to the rear which disengages it from its function lever.

S. Answer-Back Mechanism

4.115 The answer-back mechanism illustrated in Figures 36, 37, and 38 automatically transmits a predetermined sequence of characters for identification purposes.

4.116 A drum is coded with characters making up the answer-back sequence. When the answer-back mechanism is actuated, it rotates the drum, which sets up the code combinations in a set of answer-back contacts. The distributor converts the positions of the contacts to start-stop signals for transmission. After the answer-back sequence has been transmitted, the answer-back mechanism returns itself to its unoperated condition. For reasons that will be described, provisions are made for shunting the signal line during sensing of the first answer-back character of each cycle; and to prevent the answer-back from being actuated by the local generation of the answer-back call character.

4.117 The answer-back drum illustrated in Figure 35 has 11 levels as follows:

- (a) Five numbered levels
- (b) Feed ratchet
- (c) Stop cam
- (d) Character suppression
- (e) Three more numbered levels

4.118 Viewing it from the numbered end, the answer-back drum has 21 rows, ST (start) and 1 through 20. The feed ratchet serves to rotate the drum. The stop cam has tines

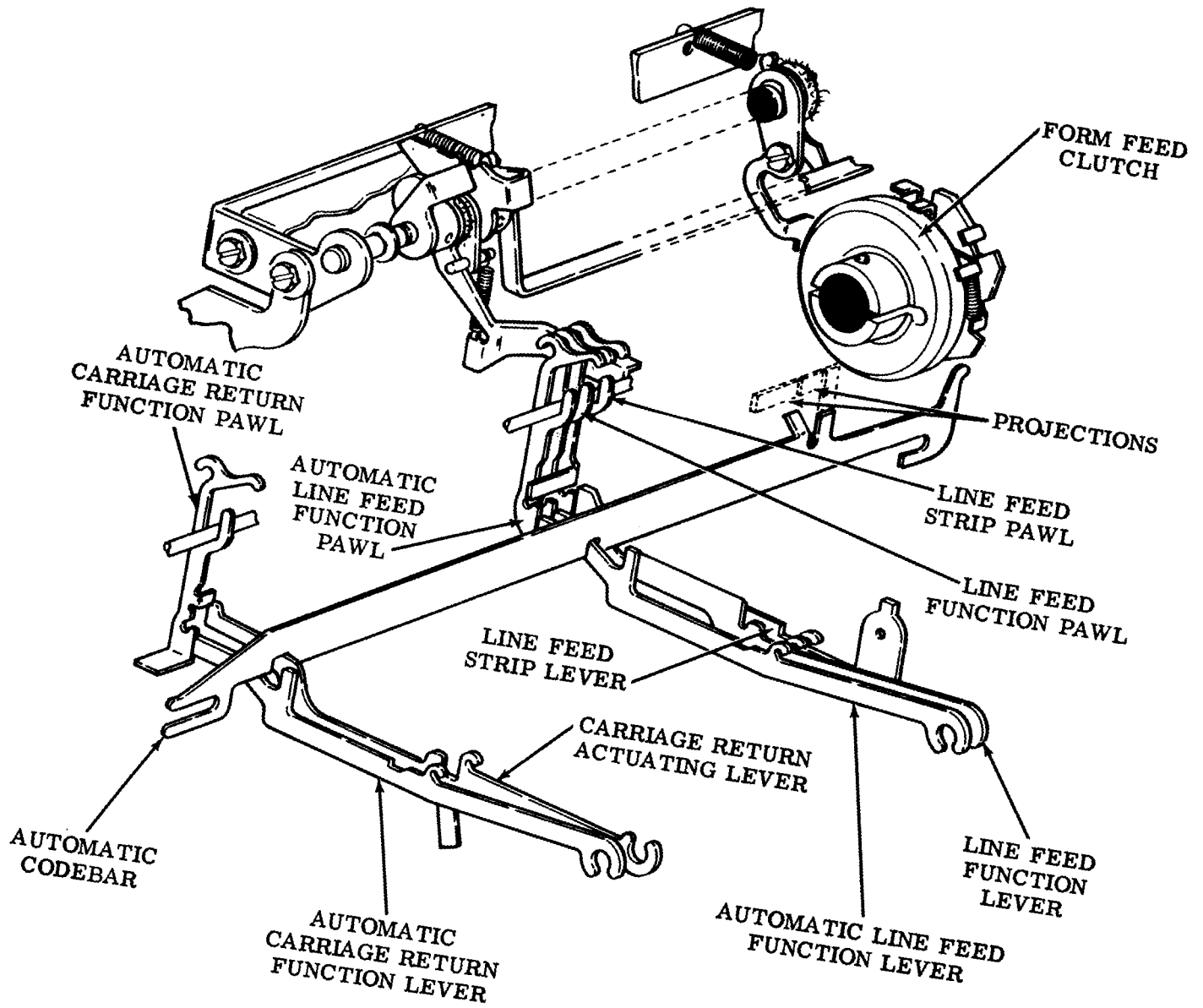

(Left Front View)

Figure 34 - Automatic Carriage Return-Line Feed Mechanism (Sprocket Feed)



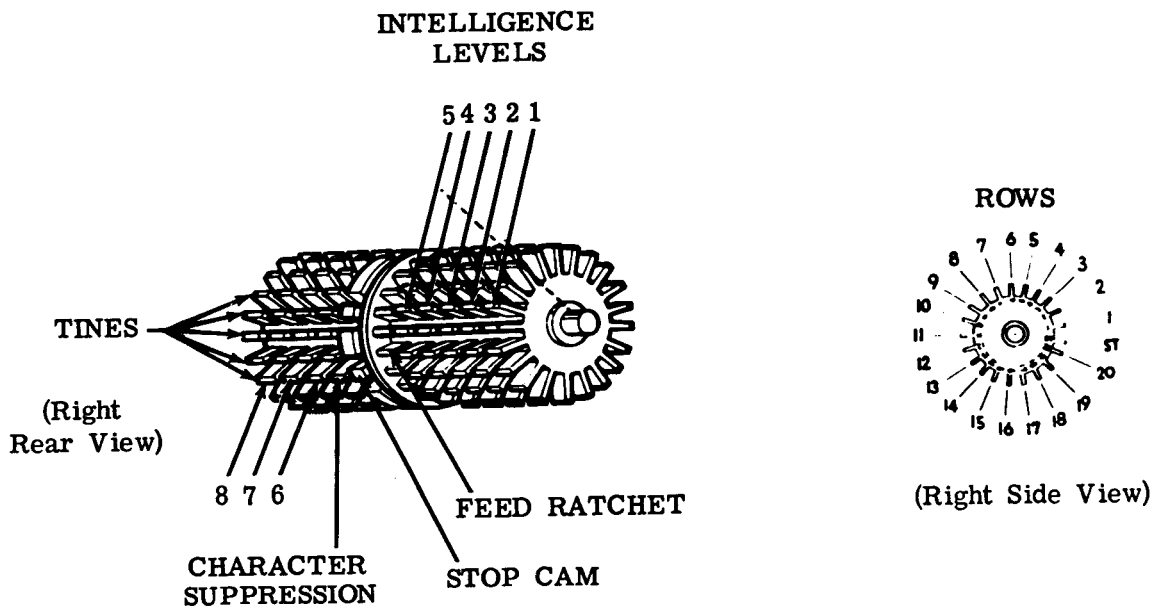

Figure 35 - Answer-Back Drum

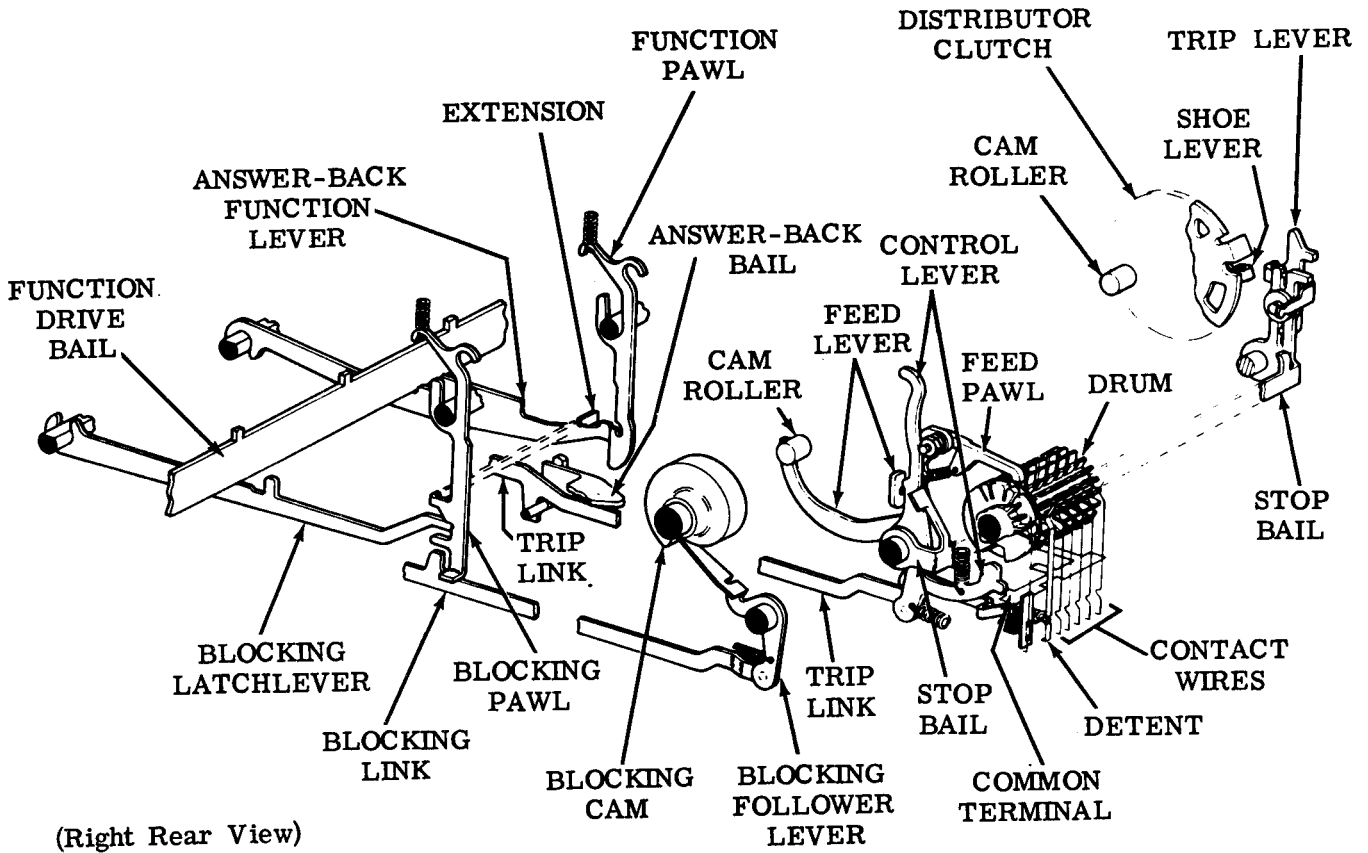

Figure 36 - Answer-Back Mechanism Remote Actuation

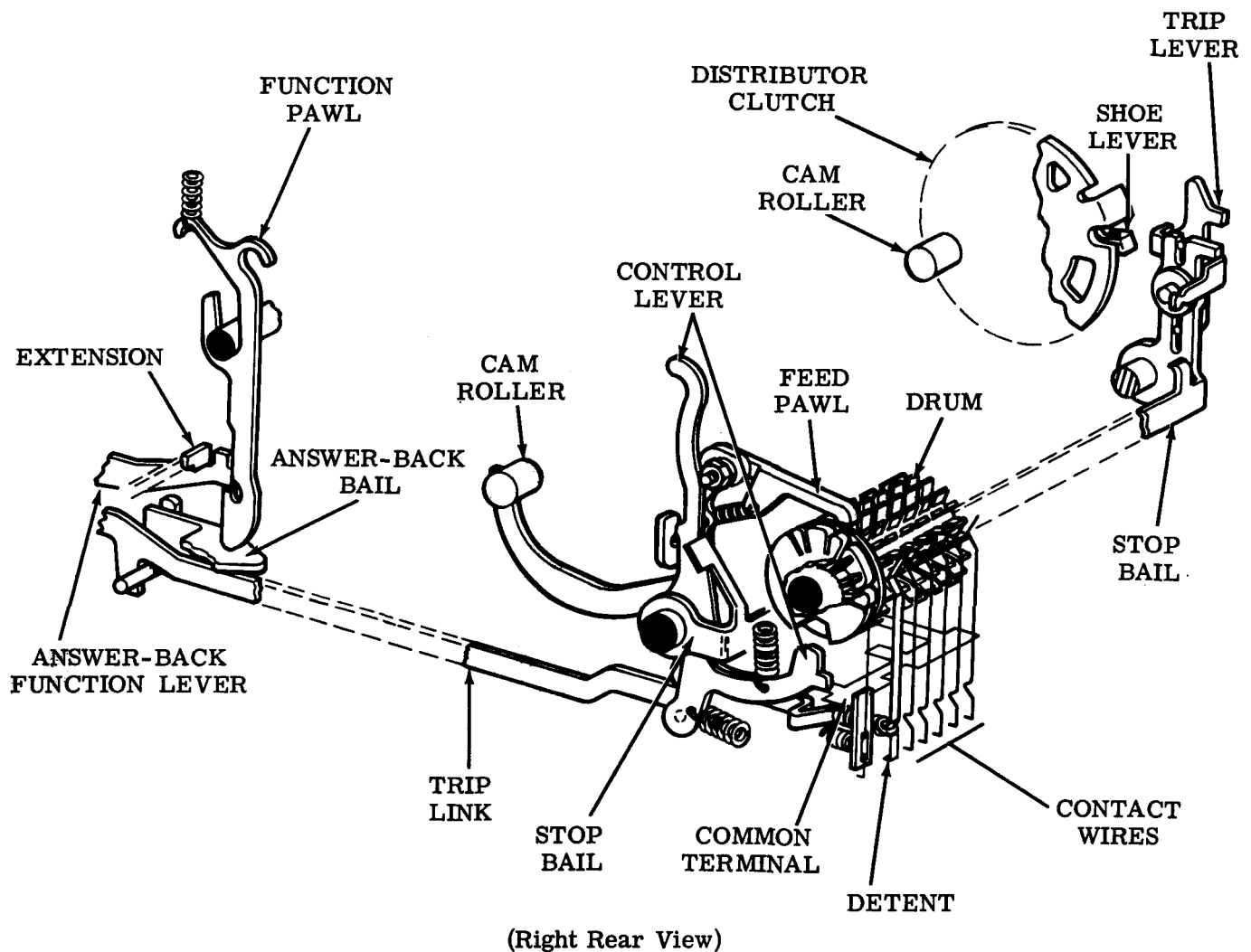

Figure 37 - Answer-Back Mechanism Local Actuation

which can be removed at various points so that the length of the answer-back message can be varied. The character suppression level is used to shunt the first answer-back character from the signal line. By breaking off tines in the various rows at the numbered intelligence levels, the drum may be coded to generate the proper answer-back characters. For example, if the first character of an answer-back message to be transmitted is the letter D code combination (--3---7-), tines at the no. 3 and no. 7 levels should be broken off in the appropriate row where the answer-back message is to start. The second character of the message would be coded into the next succeeding row.

Note 1: All answer-back messages should be preceded by the "carriage return," and "line feed" code combinations.

Note 2: For details on answer-back drum coding refer to the adjustment Section 574-122-700TC.

- 4.119 The answer-back mechanism can be actuated in three ways.
- (a) Remotely, by the reception of a pre-determined call character.
 - (b) Locally, by depressing the HERE IS key.

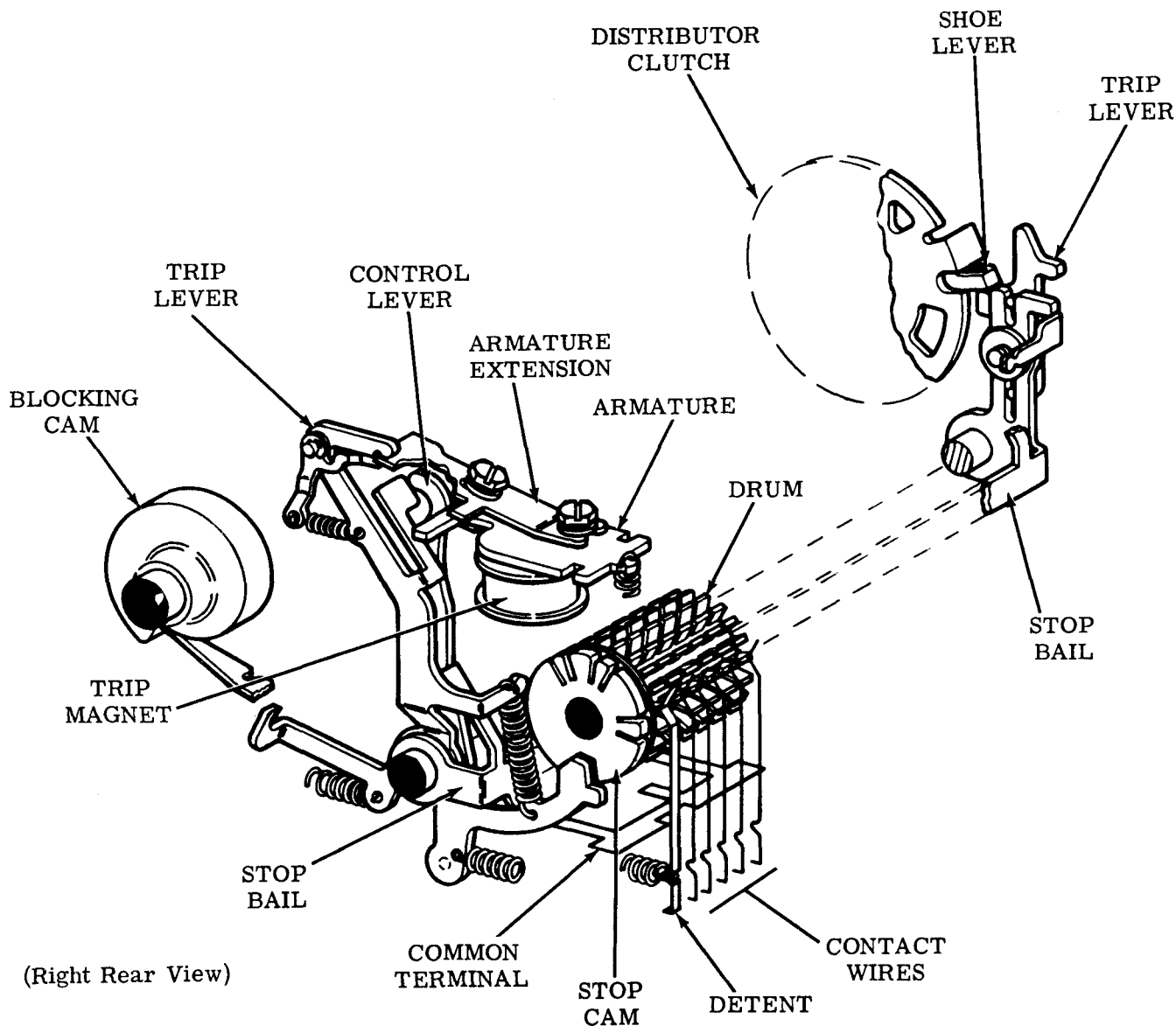

Figure 38 - Answer-Back Mechanism Automatic Actuation

(c) Automatically, by actuating the answer-back trip magnet mechanism from some external equipment, such as a data set.

4.120 Remote Actuation (Figure 36): When the answer-back call character is received by the typing unit, the answer-back function lever moves up to engage its function pawl. As the function lever and pawl are moved down by the function bail, the pawl pivots the answer-back bail. In pivoting, the answer-back bail moves a trip link frontward. The trip link pivots the control lever out of the indentation on

the stop cam. The control lever, through the stop bail, moves the trip lever rearward, out of engagement with the shoe lever, allowing the distributor clutch to engage.

4.121 When the distributor clutch begins to rotate, a cam roller moves up and permits the feed lever to pivot rearward against the control lever. The feed pawl attached to the feed lever moves rearward to engage the next tooth on the drum ratchet. Near the end of the function cycle the function pawl is stripped from its function lever by the stripper bail. The

control lever, under spring tension, tends to return to its unoperated position in the indentation of the stop cam. This would terminate the answer-back operation by disengaging the distributor clutch. However, since the feed pawl is engaged with the next tooth on the ratchet, the spring tension on the control lever is not enough to overcome the combined tension of the feed lever spring and the drum detent. Thus the mechanism remains in its operated condition throughout the distributor cycle.

4.122 Near the end of the distributor cycle, the cam roller on the distributor clutch moves the feed lever and feed pawl frontward, and the pawl acts on the ratchet to rotate the drum one tooth. The stop cam on the drum now prevents the control lever and trip lever from returning to their stop position. The distributor clutch thus continues to cycle and rotates the answer-back drum.

4.123 The answer-back contacts are wired in parallel with the keyboard contacts to the segments of the distributor disc. As the drum rotates during the answer-back operation, the contact wires, under spring tension, sense each row of tines. If a tine has been broken off at a given level in a row, the associated wire moves frontward to its marking position against a common terminal. On the other hand, if a tine is present, it holds the wire away from the terminal in its spacing position. As the distributor clutch cycles, the distributor converts the positions of the contacts to sequential start-stop signals for transmission.

4.124 The drum continues to rotate until the next indentation in the stop cam is presented to the control lever. The latter then moves into the indentation and returns the associated parts to their unoperated position. The shoe lever then strikes the trip lever and disengages the distributor clutch. The mechanism is thus returned to its unoperated condition.

4.125 Local Actuation: When the HERE IS keytop is depressed on the keyboard, it pivots a bellcrank which moves the trip link frontward. The trip link pivots the control lever to its operated position and the answer-back proceeds as described in remote actuation (4.120).

4.126 Automatic Actuation: The answer-back mechanism of a distant station may be actuated by completing a connection through the

local data set or some other equipment. The trip magnet on the distant station is energized. Being energized it attracts the trip magnet armature which allows the trip lever to move frontward. A tab on the trip lever pivots the control lever out of the indent of the stop cam allowing the clutch to engage. As the clutch rotates the blocking cam also rotates. A blocking follower rides the blocking cam and rotates clockwise. By means of a tab the blocking follower rotates the trip lever which latches against the de-energized armature extension. It remains in this position until the magnet is again energized.

4.127 Since the answer-back, keyboard, and tape reader (where used) contacts are wired in parallel with the distributor disc, the answer-back contacts must all be in their spacing position when the mechanism is unoperated, so that they do not interfere with keyboard or tape reader transmission. Therefore, because the answer-back feed mechanism does not feed the drum until near the end of the first cycle, the first character sensed should be all spacing to prevent garbling of the regular message sent from the keyboard and/or tape reader. However, an all "spacing" character is undesirable in some systems. Therefore, a way is provided for shunting transmission from the signal line during the sensing of the first answer-back character.

4.128 As mentioned, the trip link moves frontward when the answer-back sequence is initiated and remains there until it is terminated. In this position it permits a character suppression contact wire to sense the drum character suppression level. The character suppression contact is wired so that it shunts transmission from the outgoing signal line when it is closed. The tine at the character suppression level of the first character of each answer-back cycle must always be broken off in order to accomplish this. Thus the character suppression contact wire is selected and keeps the line marking until the second character is sensed. The tines are left in the character suppression level in other rows, except for certain conditions, such as to correct coding errors and to vary the message length. This allows, in effect, one character delay before the message coded into the answer-back drum is transmitted. At the end of the operation, the trip link again moves rearward and holds the contact wire unselected while the mechanism is unoperated.

4.129 Answer-back Suppression on Transmission: Since the typing unit receives every code combination that it transmits, the sending of the answer-back call character would actuate the local answer-back as well as the one at the distant station. To prevent this, a blocking mechanism prevents the function mechanism from operating in the answer-back area during transmission.

4.130 As the distributor clutch rotates, the blocking cam pivots the blocking follower lever which pulls a blocking link rearward. The link pivots the blocking pawl rearward until it releases a blocking latchlever which, under spring tension, moves up against the function drive bail. When the function drive bail and the blocking latchlever move up during the function cycle, the blocking latchlever cams the blocking pawl further rearward where an extension on the pawl is over an extension on the answer-back function lever. The function lever is thus prevented from moving up far enough to be latched by its pawl and initiate the answer-back sequence.

4.131 During the latter part of the distributor cycle, the blocking cam allows the blocking link to move frontward to its unoperated position. As the function drive bail moves down during the middle portion of the function cycle, it drives the blocking latchlever downward to the point where the blocking pawl is permitted to pivot frontward to its unoperated position. Thus every time a character is initiated locally, the distributor clutch cycles and operates the blocking mechanism which prevents the answer-back function lever from sensing the codebars and initiating the answer-back sequence regardless of what character is processed by the typing unit. On the other hand, when remotely initiated characters are received, the distributor clutch does not cycle, the blocking mechanism is not operated, and the function lever is permitted to sense the codebars and initiate the answer-back sequence upon receipt of the predetermined call-character signal.

4.132 The length of the answer-back sequence can be varied either by altering the stop-cam level or the character-suppression level.

- (a) Stop Cam: The answer-back mechanism can be coded for either 1-, 2-, or 3-cycle operation by removing the appropriate tine(s) from the stop-cam level. In 1-cycle operation, the stop cam in row "6" is removed.

This coding yields a maximum of 20 rows which are available for coding different characters into the answer-back drum. There are actually 21 rows on the answer-back drum, but only 20 rows can be used for coding since one row is suppressed. The number of rows available for message coding is summarized below for 1-, 2-, or 3-cycle operation:

<u>Cycle Operation</u>	<u>Actual Rows</u>	<u>Available Rows</u>
1	21	20
2	10(11)*	9(10)*
3	7	6

* Alternately, one then the other.

When multiple-cycle operation is employed, the answer-back sequence must be coded in each segment of the answer-back drum so that the same message will be transmitted each time the answer-back mechanism is initiated.

- (b) Character Suppression: Quite often, due to message length, messages coded into the answer-back drum do not require the use of every available row for coding. Unneeded rows are eliminated from the message transmission by removing the unneeded character suppression tine(s). The answer-back drum will stop through its complete cycle, but the transmission of the coded characters from the unneeded rows will be shunted from the signal line.

Note: The character-suppression tine in the last row of a cycle should not be removed on 33 typing units used in systems where a response to each answer-back actuation signal must always be obtained. If the tine is removed, the answer-back mechanism will not respond to consecutive answer-back actuation signals. This is due to the operating characteristics of the typing unit which, when the character-suppression tine in the last row of a cycle is removed, leaves the answer-back blocking panel blocking at the end of the answer-back drum cycle of operation. The answer-back blocking pawl will remain blocking until after another character is received through the selector mechanism. The subsequently received character causes the function mechanism to reset the answer-back blocking pawl to its unblocking position. After being reset and

upon receipt of an answer-back actuation signal, the answer-back mechanism will be triggered. Hence, with the character-suppression time removed from the last row of an answer-back cycle, typing unit answer-back mechanisms will only respond to every other answer-back actuation signal unless an intervening character is received through the selector mechanism.

5. OPTIONAL FEATURES

PRINT NONPRINT

5.01 The function of the print nonprint mechanism is to block all the function levers from rising (except the print suppression function lever) during the function cycle. There are

two types of print nonprint mechanisms, one magnet operated and one solenoid operated.

A. Magnet Operated

5.02 The magnet operated print nonprint mechanism shown in Figure 39 allows transmission or reception of tape messages without printed page copy. An on and off toggle switch and a red indicator lamp mount to the right of the platen on the call control unit panel. The switch controls a magnet attached to the typing unit casting. The red indicator lamp lights when the mechanism is activated and the typing unit placed in the nonprint mode. Operation of the magnet attracts an armature which pivots a bellcrank. Operation of the bellcrank moves a nonprint codebar which blocks all the function levers except a special function lever. This special function lever rises every cycle. In so doing, it blocks the print suppression

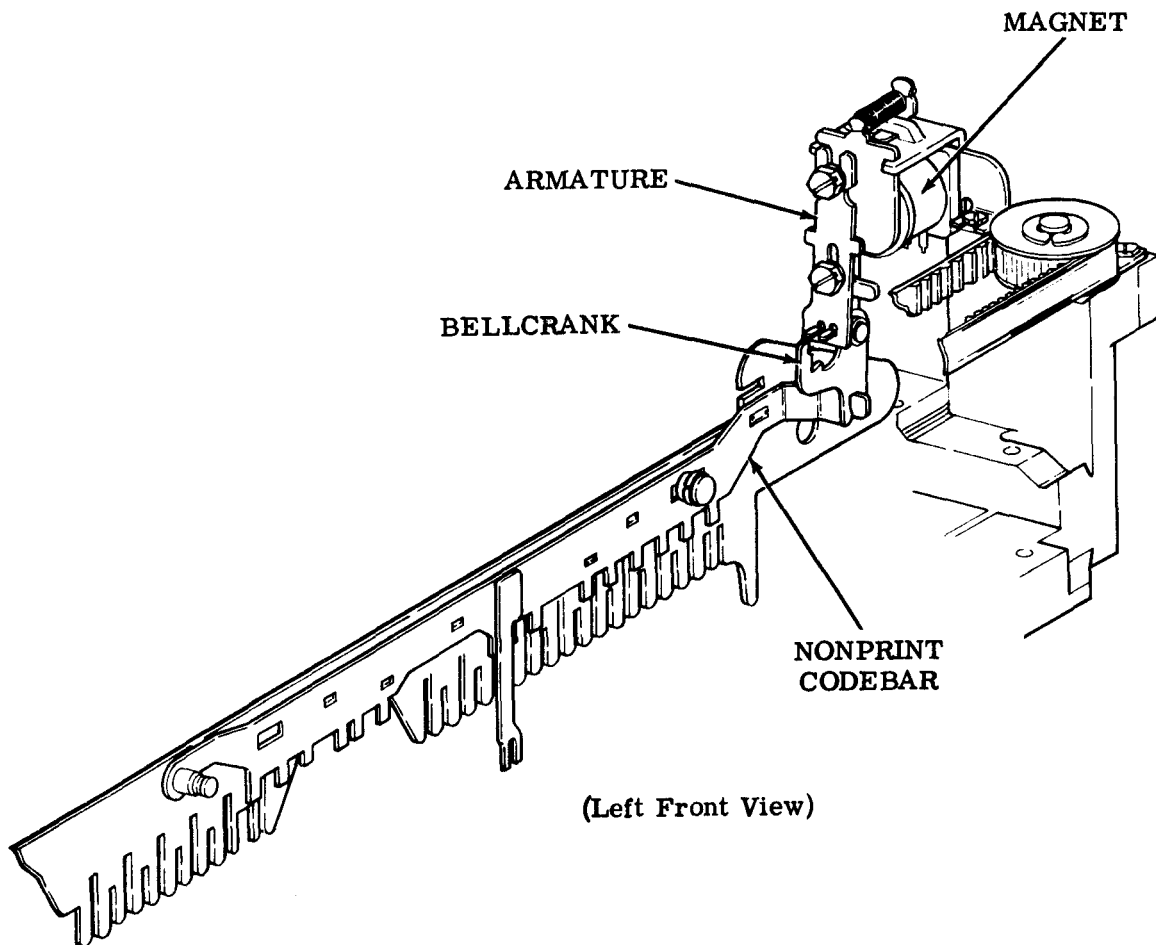

Figure 39 - Magnet Operated Print Nonprint Mechanism

codebar and thus printing is suppressed. Turning the mechanism off extinguishes the indicator light and the nonprint codebar returns to its unoperated position under spring tension.

B. Solenoid Operated

5.03 The solenoid operated print nonprint mechanism shown in Figure 40 is a remote-controlled device consisting of a bracket

which supports a solenoid. At the end of the solenoid plunger is attached a lever which is part of the nonprint codebar. Activation of the solenoid pulls the plunger and thus positions the nonprint codebar, blocking all the function levers except the print suppression function lever. Operation of the print suppression function lever suppresses printing. At the receipt of the off signal the nonprint codebar moves to its unoperated position under spring tension.

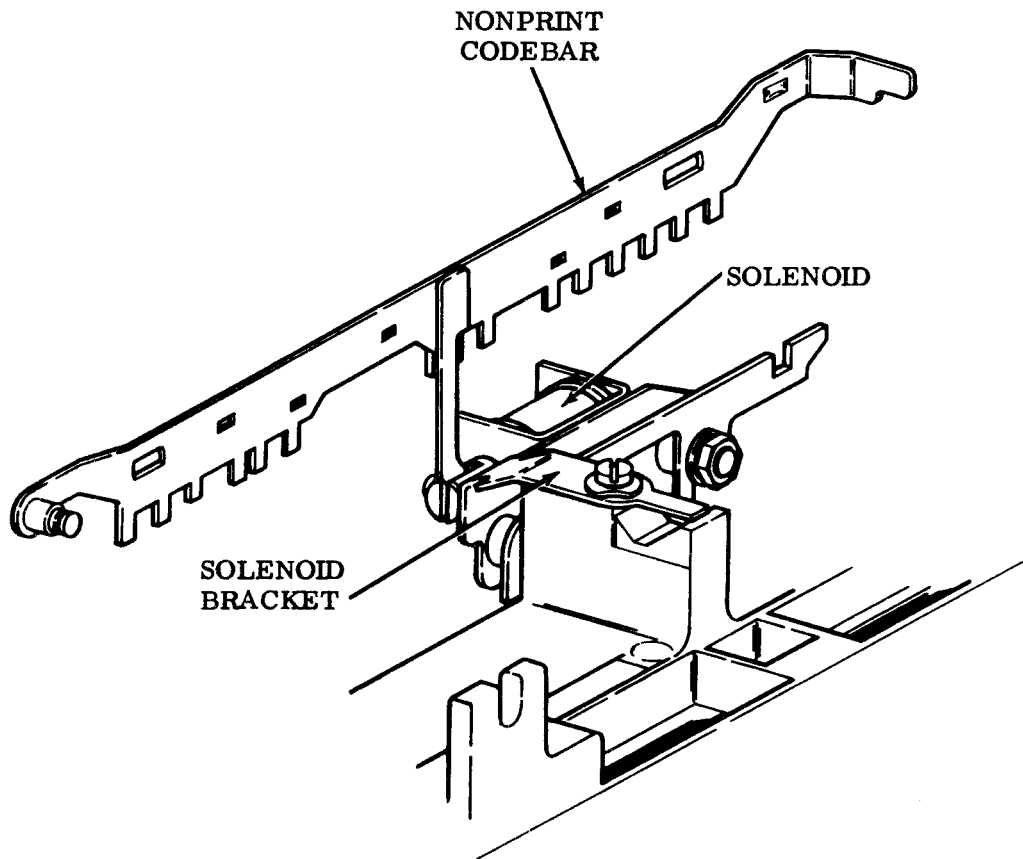

(Left Front View)

Figure 40 - Solenoid Operated Print Nonprint Mechanism

33 TYPING UNIT

LUBRICATION

CONTENTS	PAGE	CONTENTS	PAGE
1. GENERAL	1	Stripper drive lever	9
2. BASIC UNITS	3	Trip lever	8
COMMON MECHANISMS	3	Trip shaft	4
Armature	18	Typewheel mechanism	16
Automatic codebar	9	FRICITION FEED MECHANISMS	20
Blocking levers	18	Line feed mechanism	21
Carriage area	13	Paper feed area	20
Carriage rear rail	17	Platen	20
Carriage return and spacing levers . .	12	SPROCKET FEED MECHANISMS	21
Codebars	9	Cam, pulley, and gear combination . .	23
Codebar clutch	4	Form-out mechanism	24
Dashpot	14	Line feed clutch	25
Disc and brushes	7	Paper feed area	21
Distributor area	6	Platen mechanism	22
Drive arm	15	Platen drive area	23
Drive mechanism	11	3. VARIATIONS TO BASIC UNITS	25
Function area	8	Answer-back area	25
Function clutch	3	Answer-back mechanism	26
Function levers	9	Trip magnet	26
Function rocker shaft	6	Print nonprint mechanism	27 ←
Function shaft area	5	1. GENERAL	
Intermediate gears	5	1.01 This section provides lubrication instructions for the 33 typing unit. It is reissued to include lubrication instructions for the print nonprint mechanisms present on 3300 Series Coded Sets and Computer Input/Output Sets. Marginal arrows indicate the addition as well as a few minor corrections throughout the section. ←	
Latchlever	7	1.02 The general lubrication areas are illustrated by photographs. The specific points to receive lubricant are indicated on line drawings with appropriate textual instructions. Line drawings and textual instructions follow each photograph and are keyed to the photograph by paragraph numbers.	
Latchlever and trip lever	19		
Main shaft area	3		
Motor area	5		
Print hammer	15		
Pushlevers and stripper bail	18		
Reset arm	15		
Reset bail	10		
Ribbon guide spring	17		
Ribbon mechanism	16		
Rocker and pawls	10		
Selector area	17		
Selector clutch	19		
Selector levers	19		
Slides	14		
Slide guideplates	14		
Spacing area	11		
Space bellcrank	11		
Spacing mechanism - 1	12		
Spacing mechanism - 2	13		
Stop bail	7		

1.03 Thoroughly lubricate the typing unit, but avoid overlubrication that might permit the lubricant to drip or be thrown onto adjacent parts. Saturate all felt washers and oilers with oil, and apply oil to each end of all bearings.

1.04 Lubricate the typing unit before placing it into service or prior to storage. After a short period of service, relubricate it to make sure no areas have been missed. Thereafter, lubricate the typing unit at regular intervals as indicated below:

<u>Operating Speed</u> (Words per Minute)	<u>Lubrication Interval</u>
100	500 hrs* or 6 mo.**

*Station set operating hours
 **Whichever comes first

1.05 On occasion when the printer is disassembled, apply a coat of thoroughly mixed 50 percent KS7470 oil and 50 percent KS7471 grease at places indicated below.

- Selector Cam Surfaces (2.44)
- Spacing Gear Teeth (2.23)
- Codebar Pivot Shaft (2.17 and 2.18)
- Eccentric Cams (2.02 and 2.04)
- Stop Bail Adjusting Tab (2.11)
- Platen Shaft Bearings-Sprocket Feed Units only (2.49)
- Distributor Shaft Cam Roller (Early Design) or Stud (Late Design) (2.13)
- H-Lever (2.13)

Note 1: On occasion when the clutch is disassembled, lubricate the Internal Clutch Assemblies (2.02, 2.04, 2.44, and 2.53 on Form Feed Mechanisms only) as follows: Apply a thin coat of KS7471 grease at the loops of the clutch shoe lever spring, and lubricate the internal mechanism of the clutch with KS7470 oil.

Note 2: At regular lubrication intervals lubricate the clutch mechanism with KS7470 oil only.

1.06 The textual instructions that accompany the line drawings consist of abbreviated directions, specific lubrication points, and parts affected. The meanings of the abbreviated directions (symbols) follow:

<u>Symbol</u>	<u>Meaning</u>
D	Keep dry — no lubricant permitted.
G	Apply thin coat of grease (KS7471).
O	Oil (KS7470).

1.07 References to left, right, front, or rear, etc, consider the typing unit to be viewed from a position where the carriage area faces up and the selector area is located to the viewer's left.

CAUTION: DO NOT USE ALCOHOL, MINERAL SPIRITS, OR OTHER SOLVENTS TO CLEAN PLASTIC PARTS OR PARTS WITH PROTECTIVE-DECORATIVE FINISHES. NORMALLY, A SOFT, DRY CLOTH SHOULD BE USED TO REMOVE DUST, OIL, GREASE, OR OTHERWISE CLEAN PARTS OR SUBASSEMBLIES. IF NECESSARY, A SOFT CLOTH DAMPENED WITH SOAP OR MILD DETERGENT MAY BE USED. AFTERWARDS, RINSE EACH CLEANED PART OR SUBASSEMBLY WITH SOFT, DAMP CLOTH AND BUFF WITH A SOFT, DRY CLOTH.

1.08 Tools and materials needed for teletypewriter lubrication are listed in Section 570-005-800TC.

1.09 For disassembly and reassembly information, refer to Section 574-122-702TC.

CAUTION: ALL ELECTRICAL POWER MUST BE REMOVED FROM UNIT BEFORE LUBRICATING OR REMOVING COMPONENTS FOR LUBRICATION.

2. BASIC UNITS

COMMON MECHANISMS

2.01 Main Shaft Area

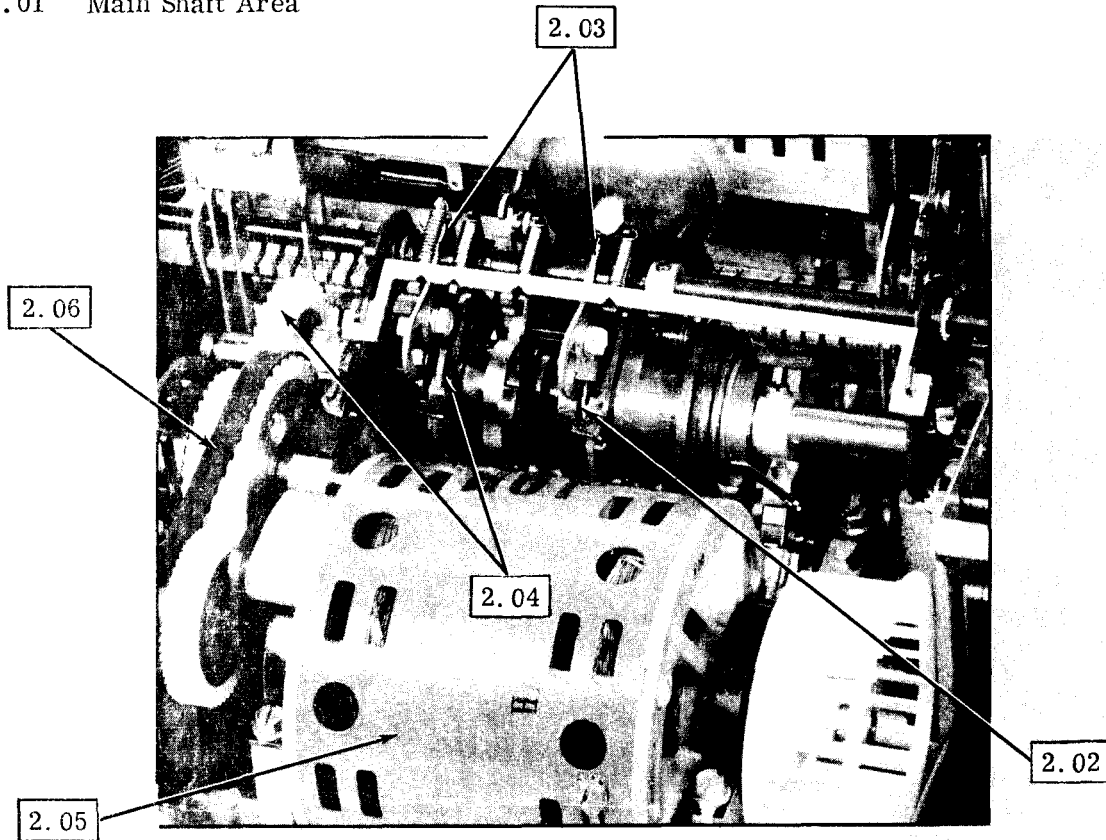

(Rear View)

2.02 Function Clutch

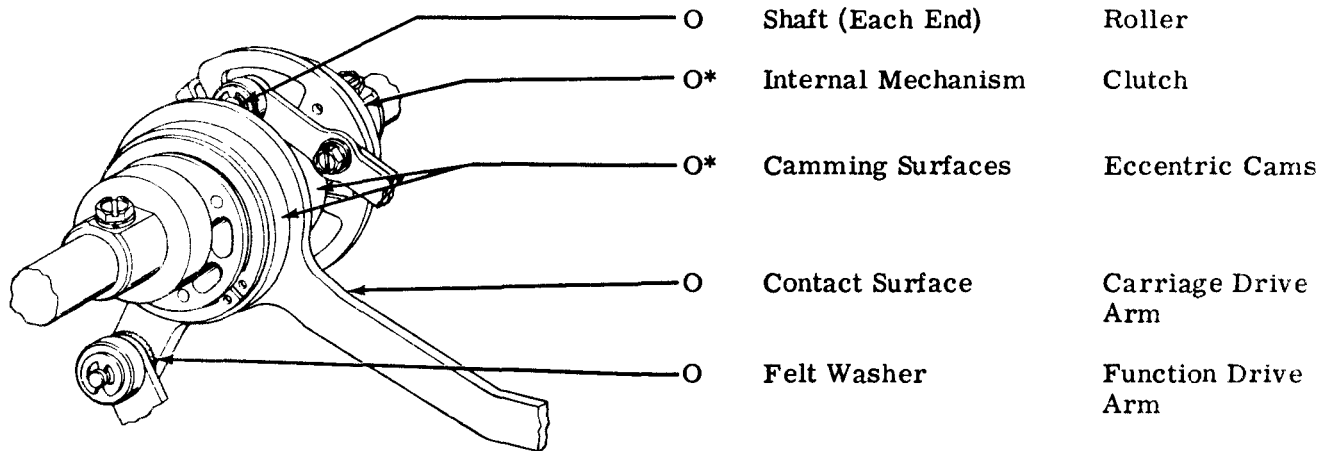

*Refer to 1.05.

(Left Front View)

2.03 Trip Shaft

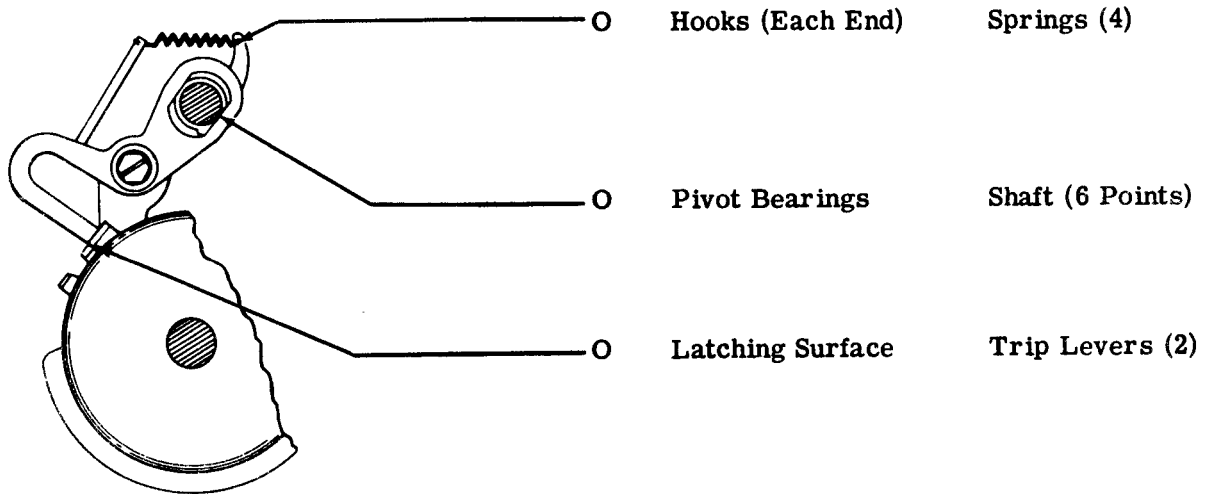

(Left Side View)

- | | | |
|---|------------------|------------------|
| O | Hooks (Each End) | Springs (4) |
| O | Pivot Bearings | Shaft (6 Points) |
| O | Latching Surface | Trip Levers (2) |

2.04 Codebar Clutch

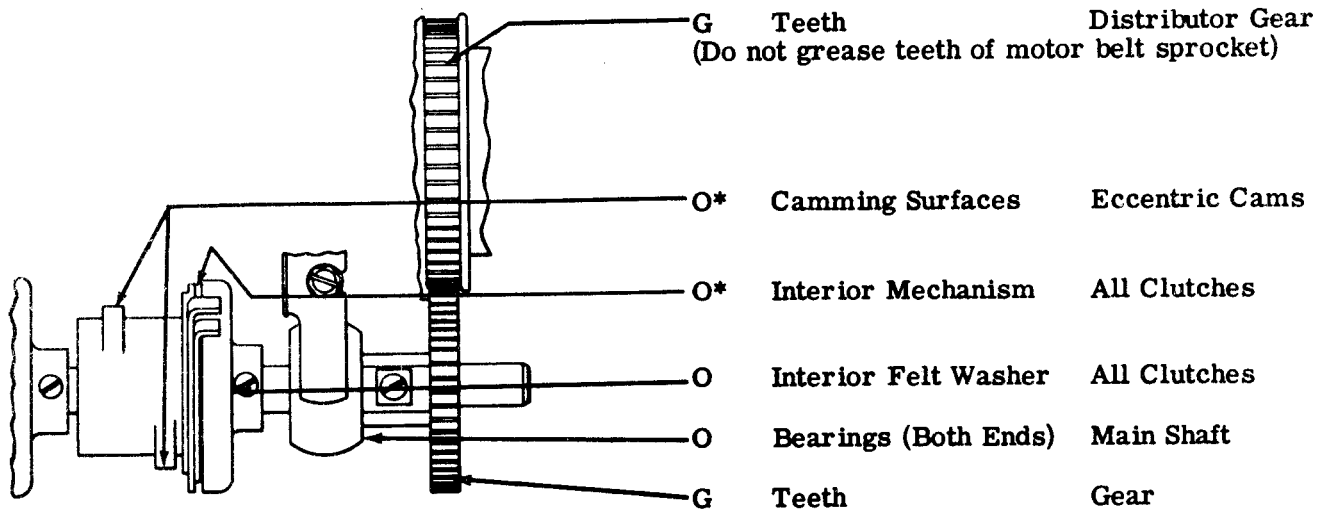

(Top View)

- | | | |
|----|--|------------------|
| G | Teeth | Distributor Gear |
| | (Do not grease teeth of motor belt sprocket) | |
| O* | Camming Surfaces | Eccentric Cams |
| O* | Interior Mechanism | All Clutches |
| O | Interior Felt Washer | All Clutches |
| O | Bearings (Both Ends) | Main Shaft |
| G | Teeth | Gear |

* Refer to 1.05.

2.05 Motor Area

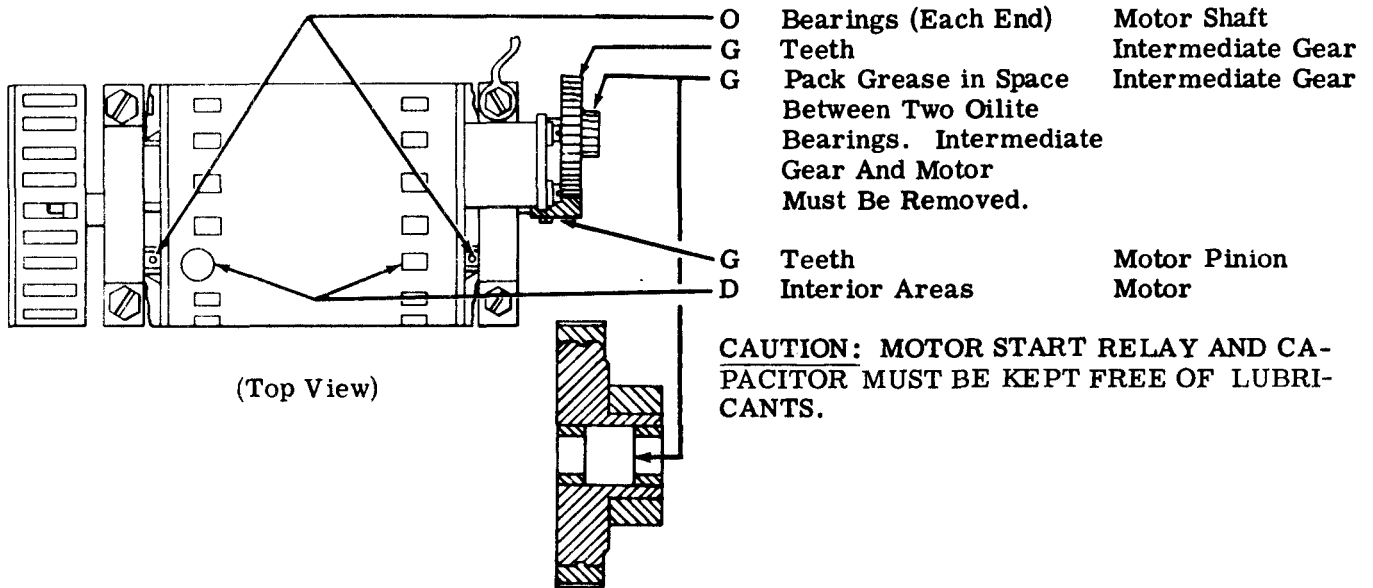

2.06 Intermediate Gears

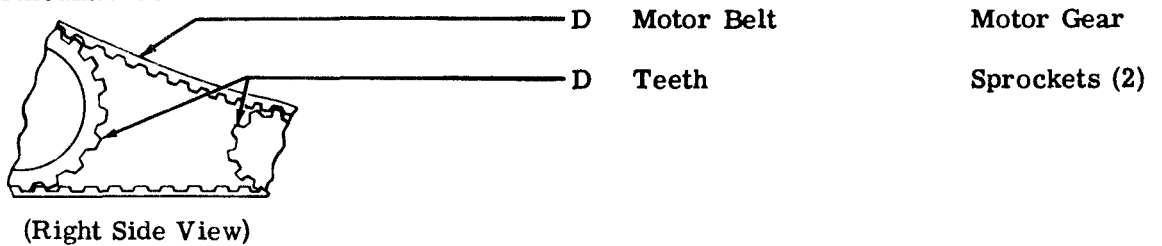

2.07 Function Shaft Area

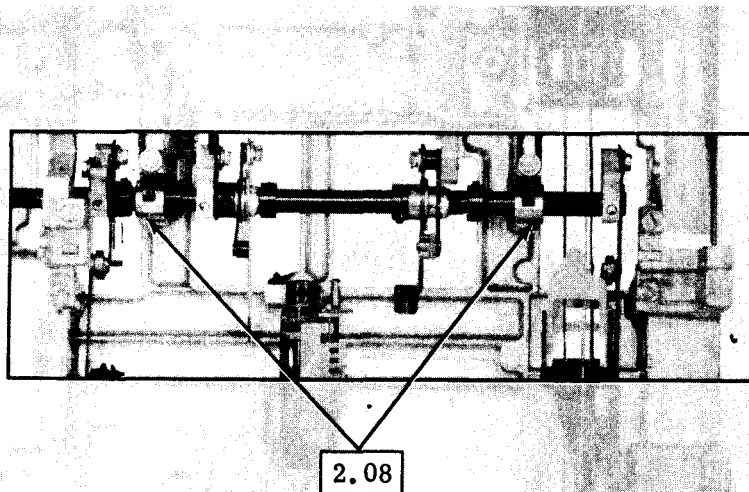

(Top View)

(Typing unit disassembled for illustration only.)

2.08 Function Rocker Shaft

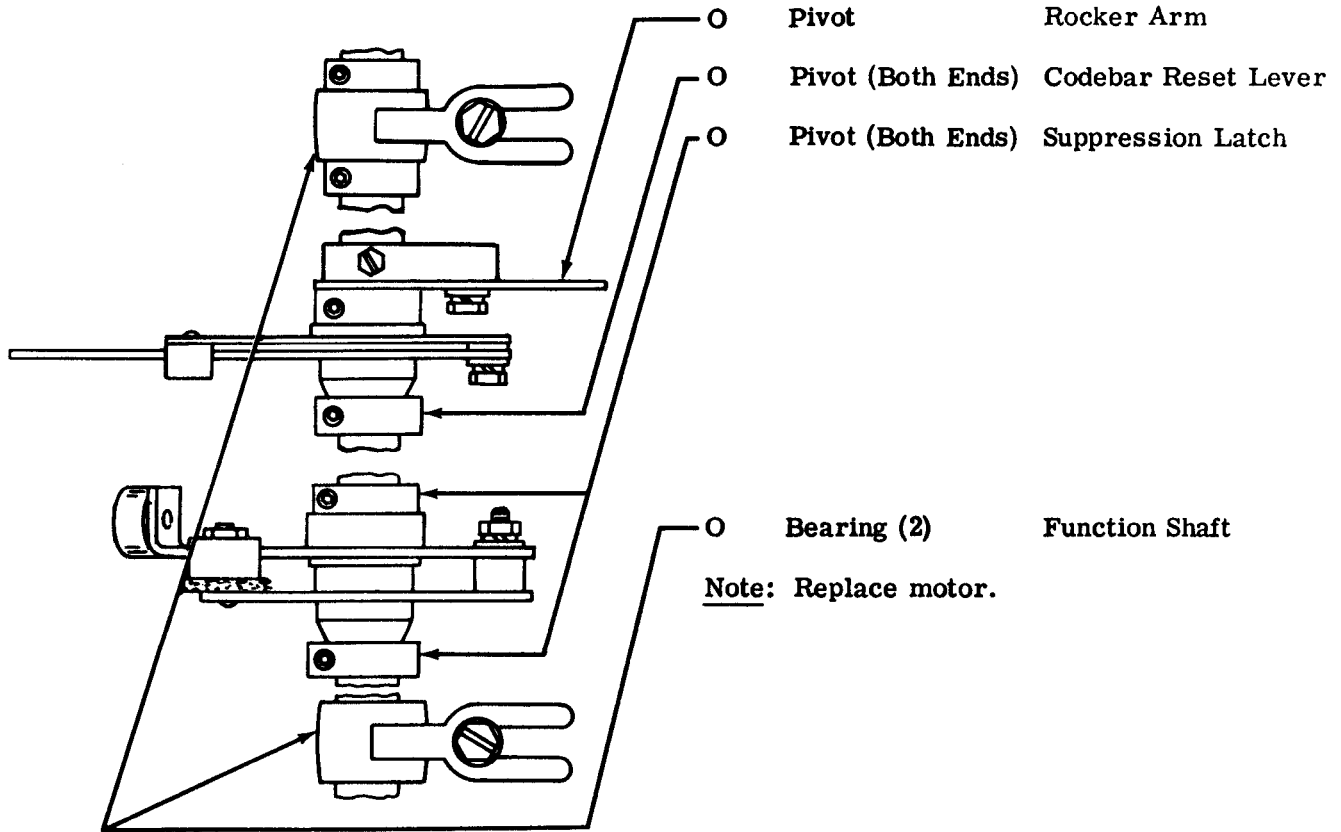

2.09 Distributor Area

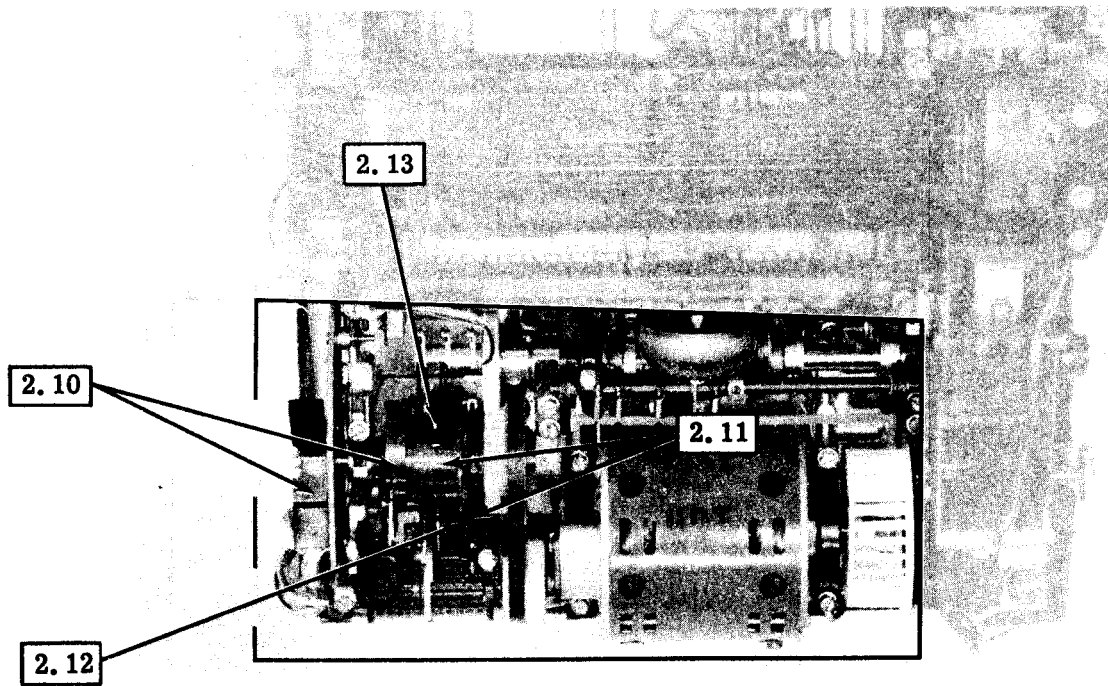

(Top View)

2.10 Disc and Brushes

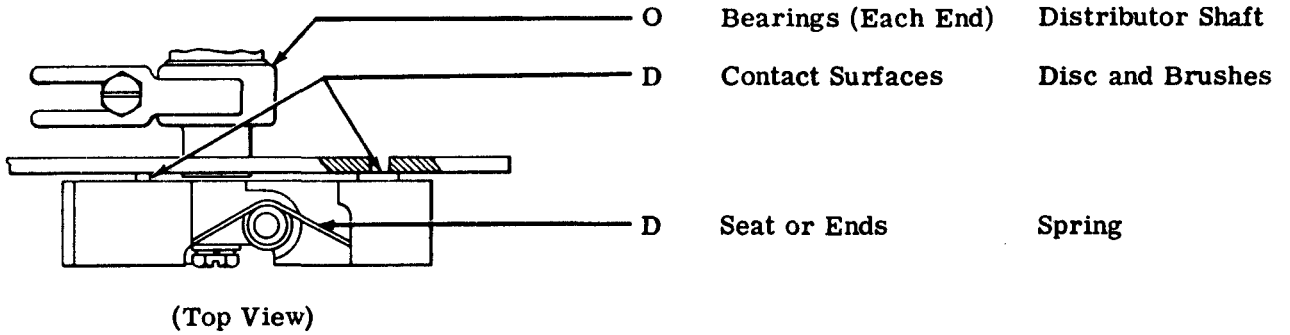

2.11 Stop Bail

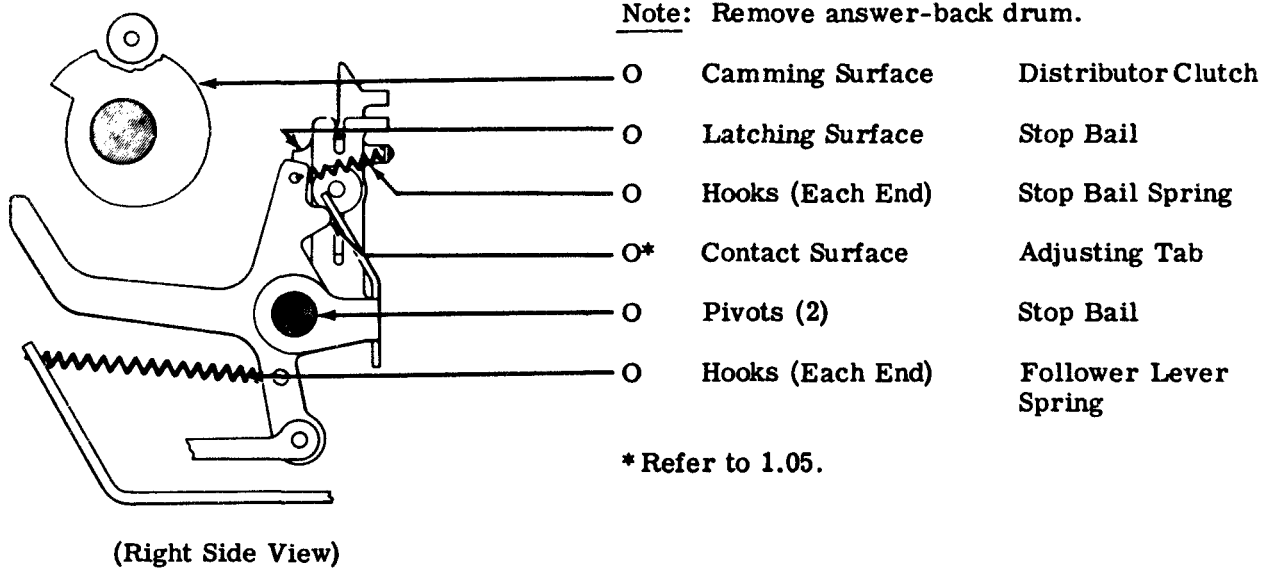

2.12 Latchlever

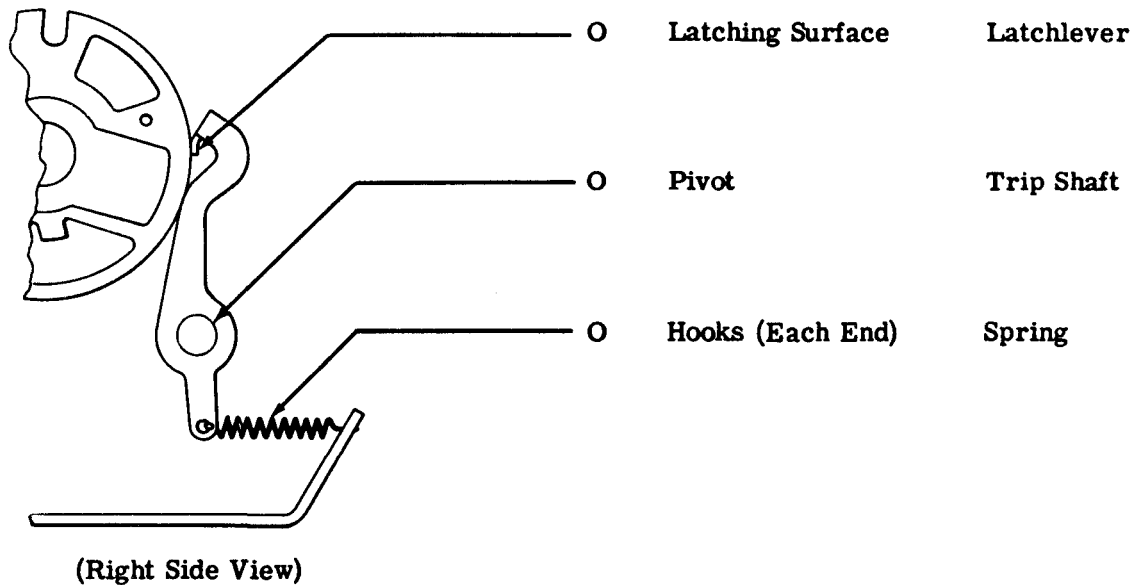

2.13 Trip Lever

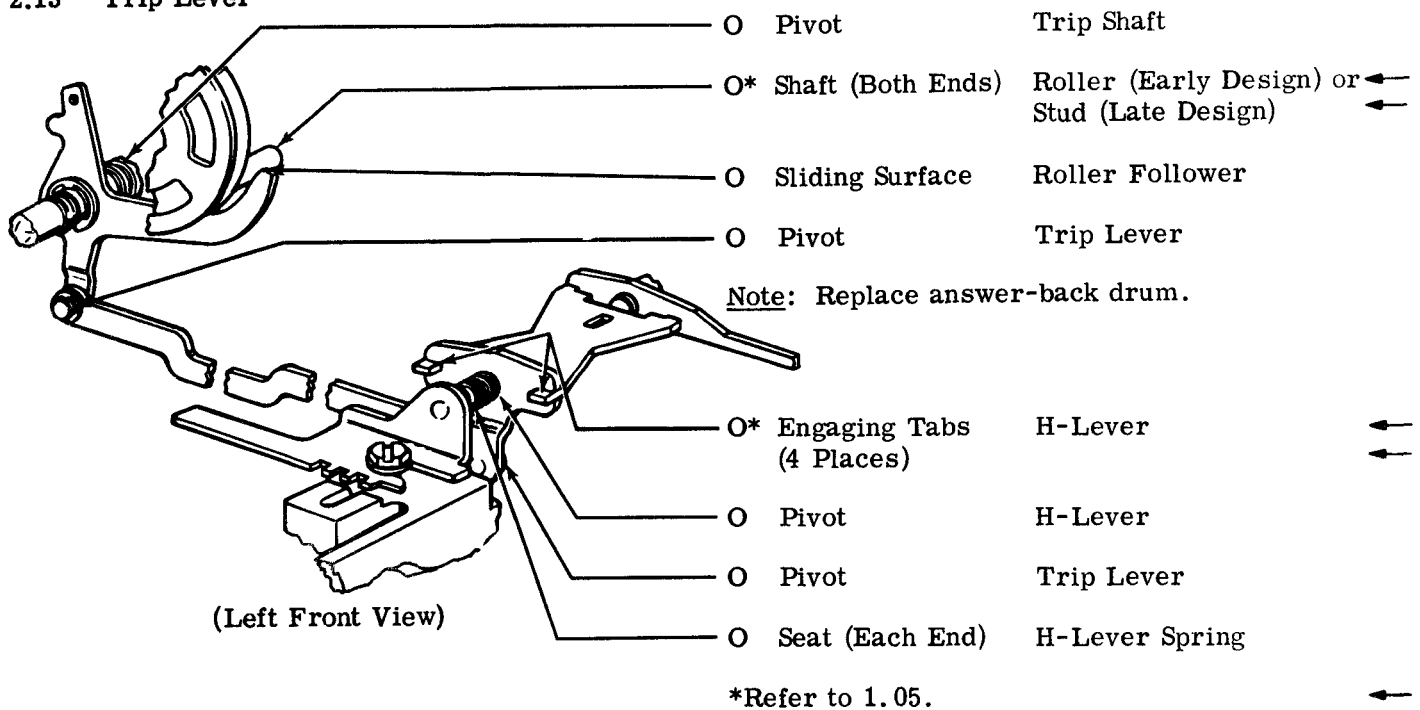

2.14 Function Area

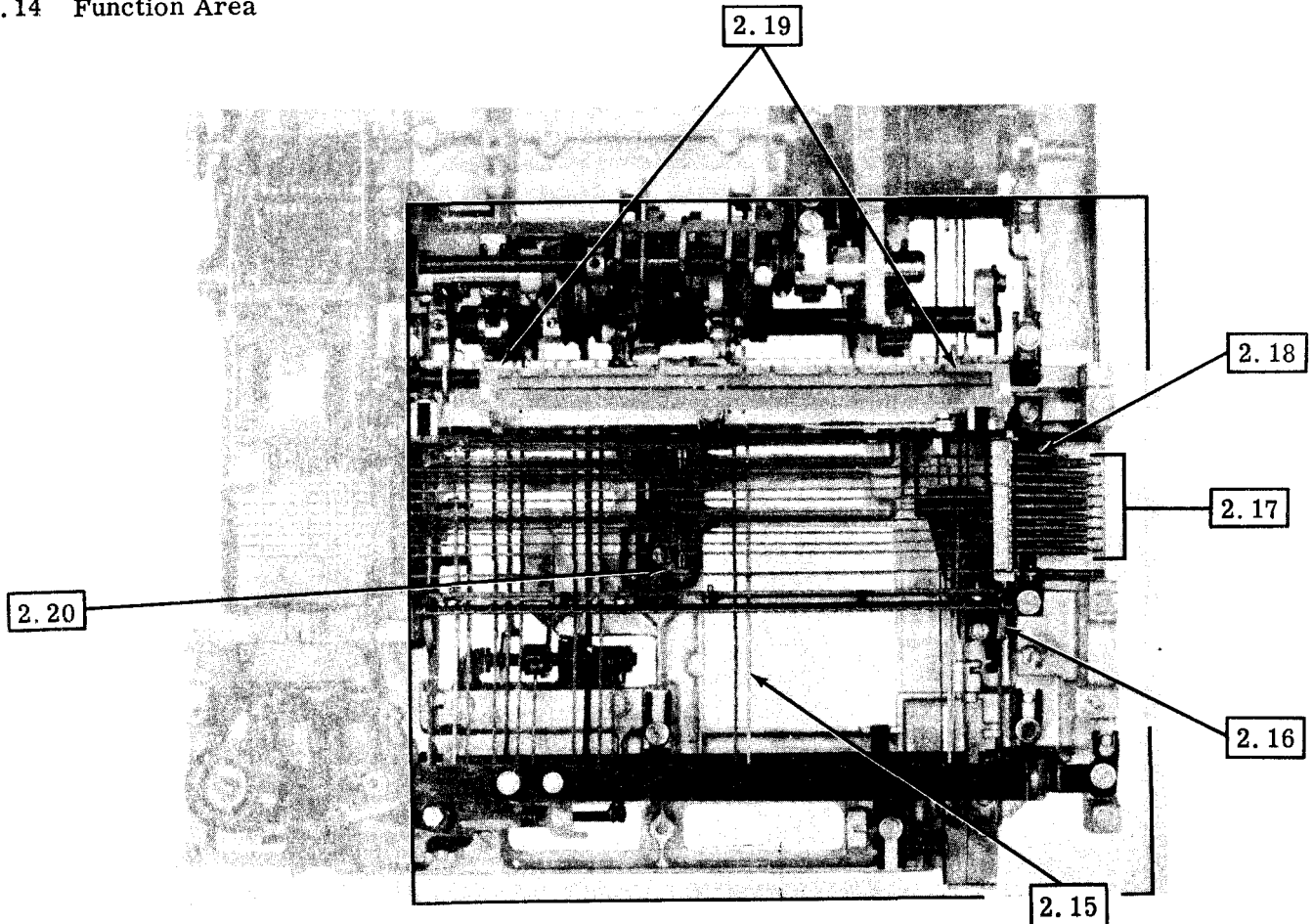

2.15 Function Levers

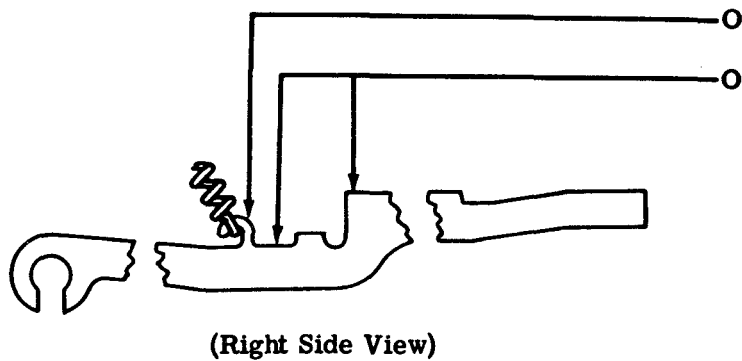

- O Hooks (Each End)
- O Engaging Surfaces
- O Springs
- O Function Levers

2.16 Stripper Drive Lever

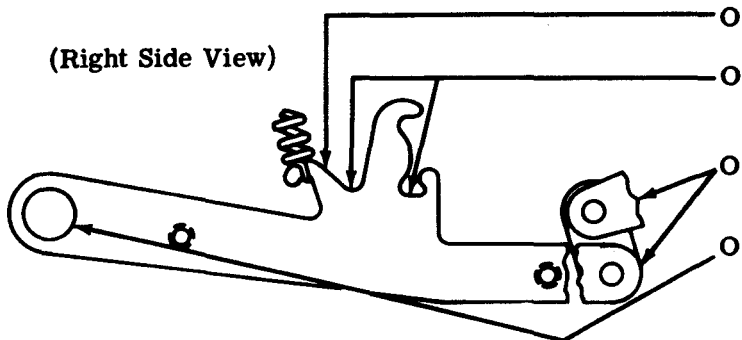

- O Hooks (Each End)
- O Engaging Surfaces
- O Pivots
- O Felt Washers (2)
(Each End of Shaft)
- O Springs
- O Stripper Drive Lever
- O Stripper Drive Link
- O Front Function Shaft

2.17 Codebars

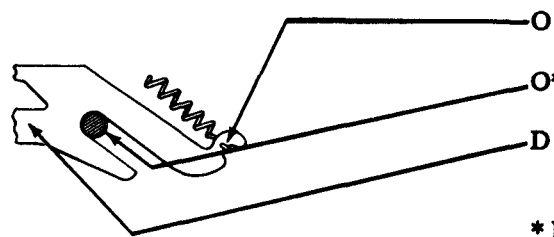

(Front View)

- O Hooks (Each End)
- O* Pivots
- D Area Between Codebars
- O Springs
- O Shaft

* Refer to 1.05.

2.18 Automatic Codebar

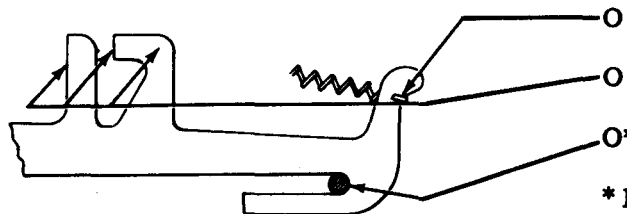

(Front View)

- O Hooks (Each End)
- O Blocking Contact
- O* Pivot
- O Spring
- O Tab (1 of 3)
- O Shaft

* Refer to 1.05.

2.19 Rocker and Pawls

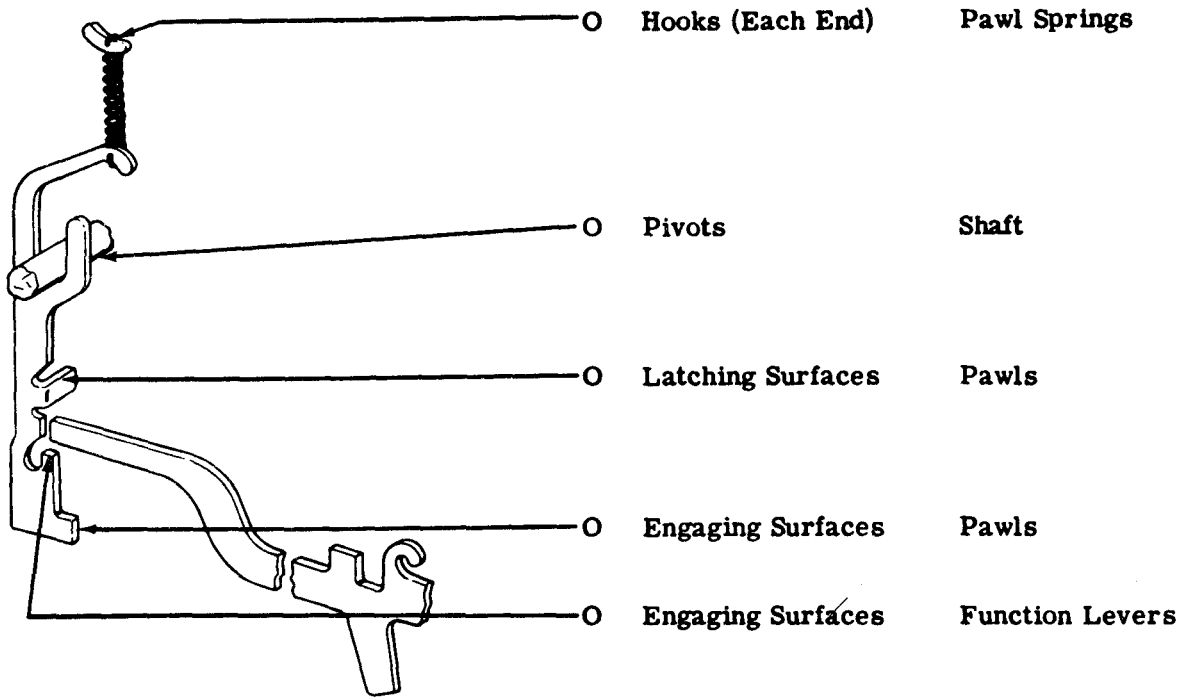

(Left Front View)

2.20 Reset Bail

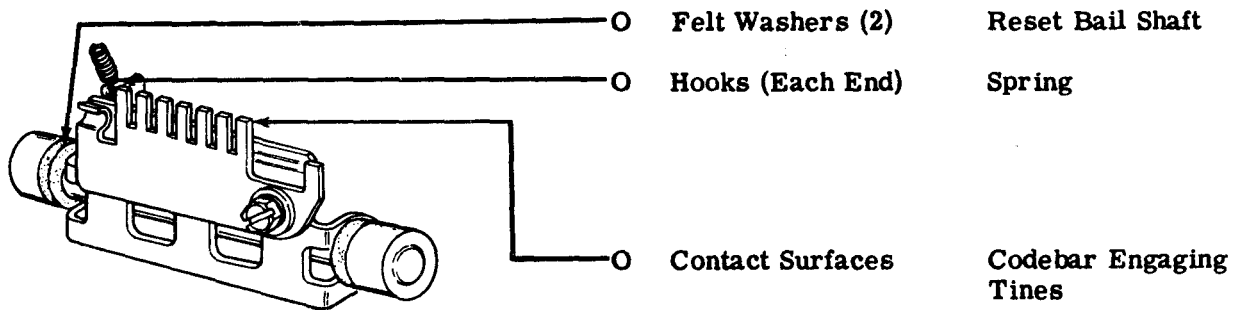

(Left Front View)

2.21 Spacing Area

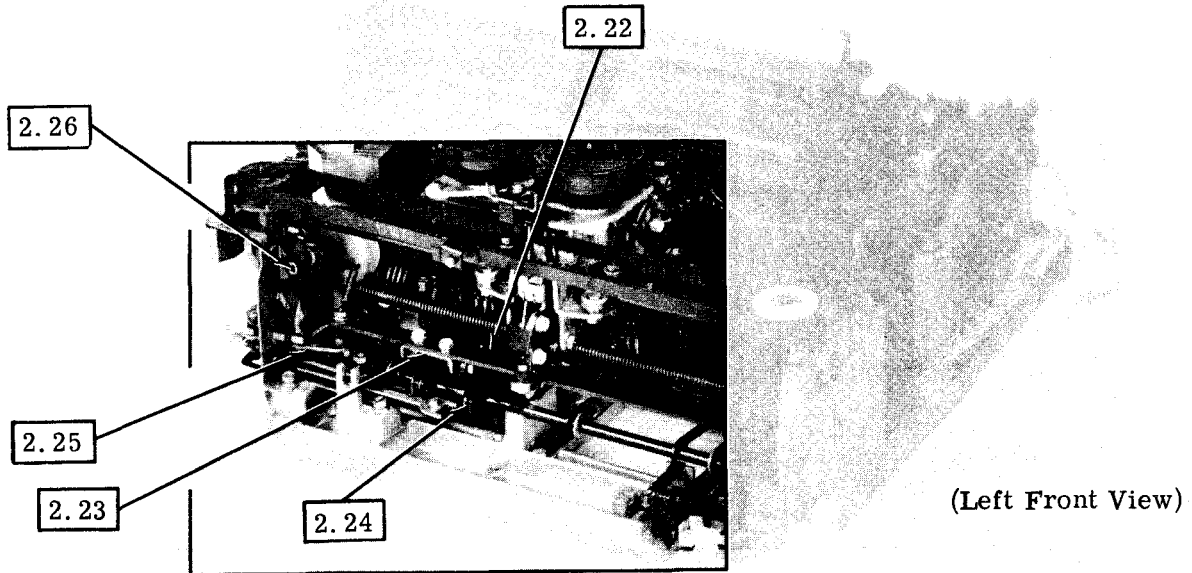

2.22 Space Bellcrank

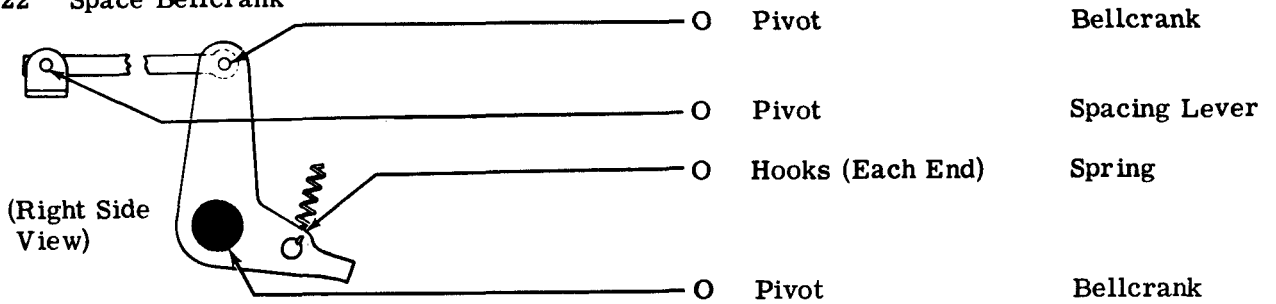

2.23 Drive Mechanism

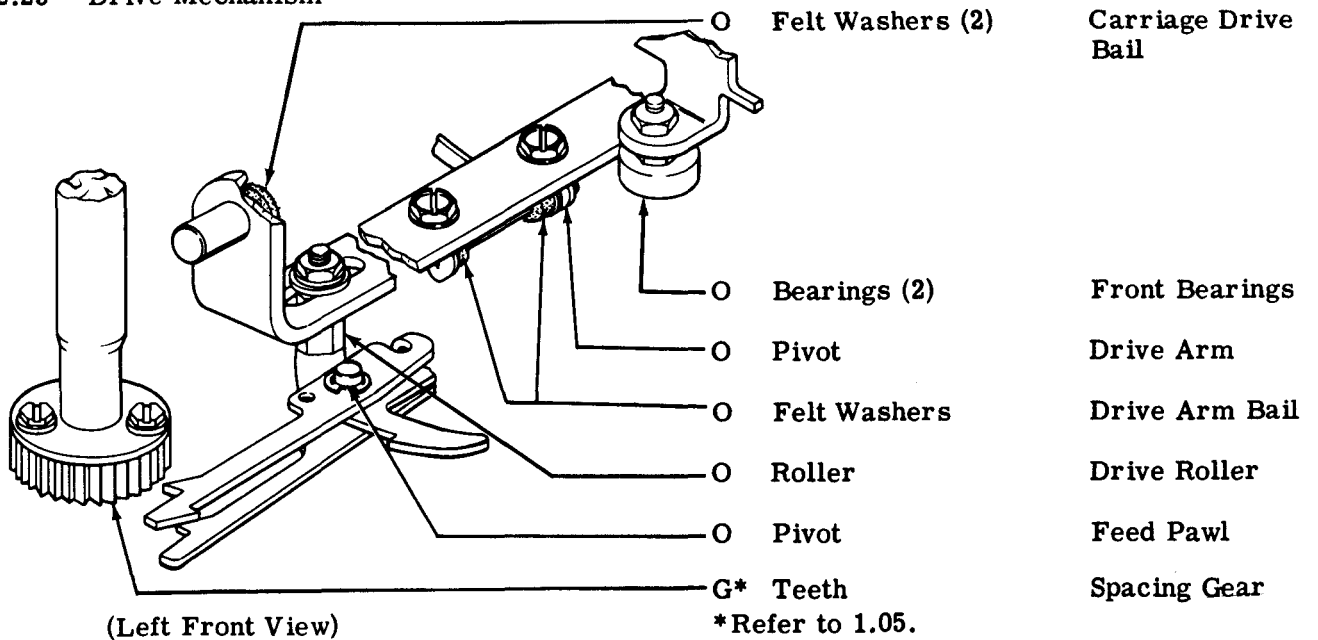

2.24 Carriage Return and Spacing Levers

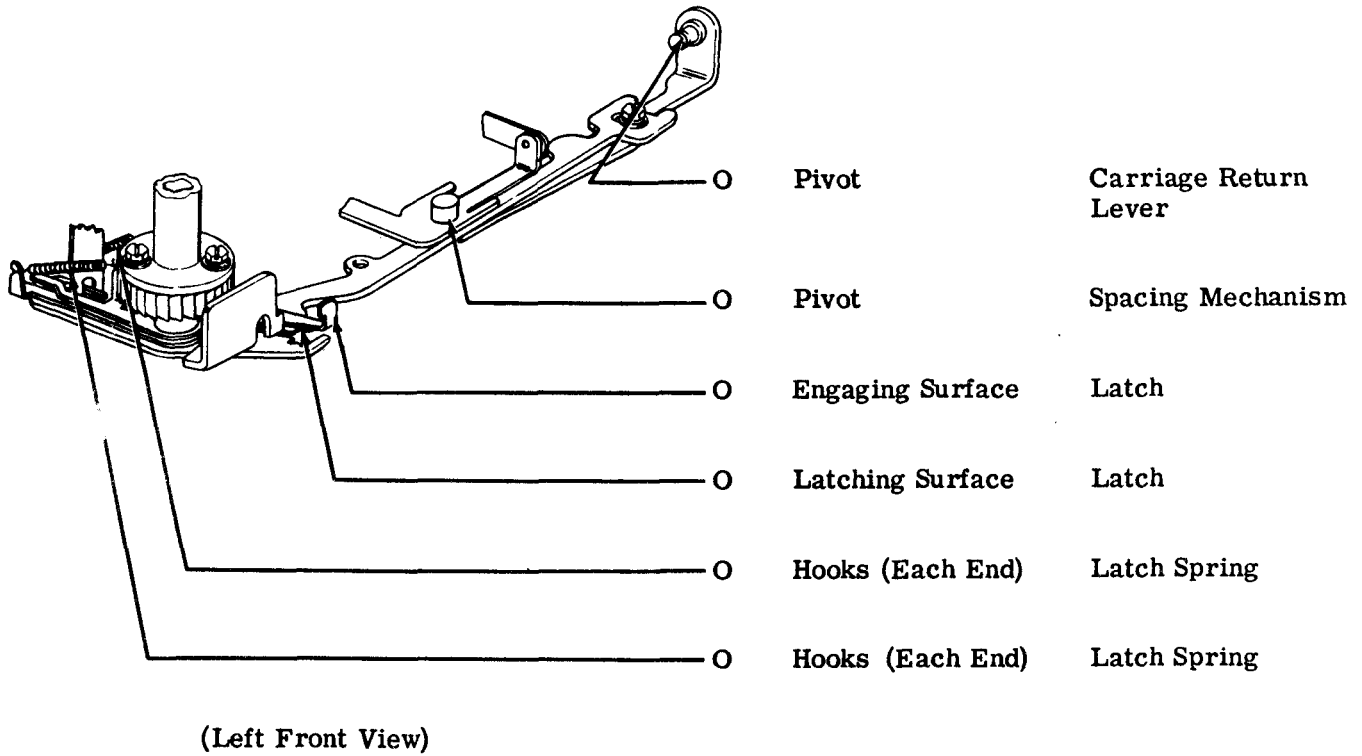

2.25 Spacing Mechanism - 1

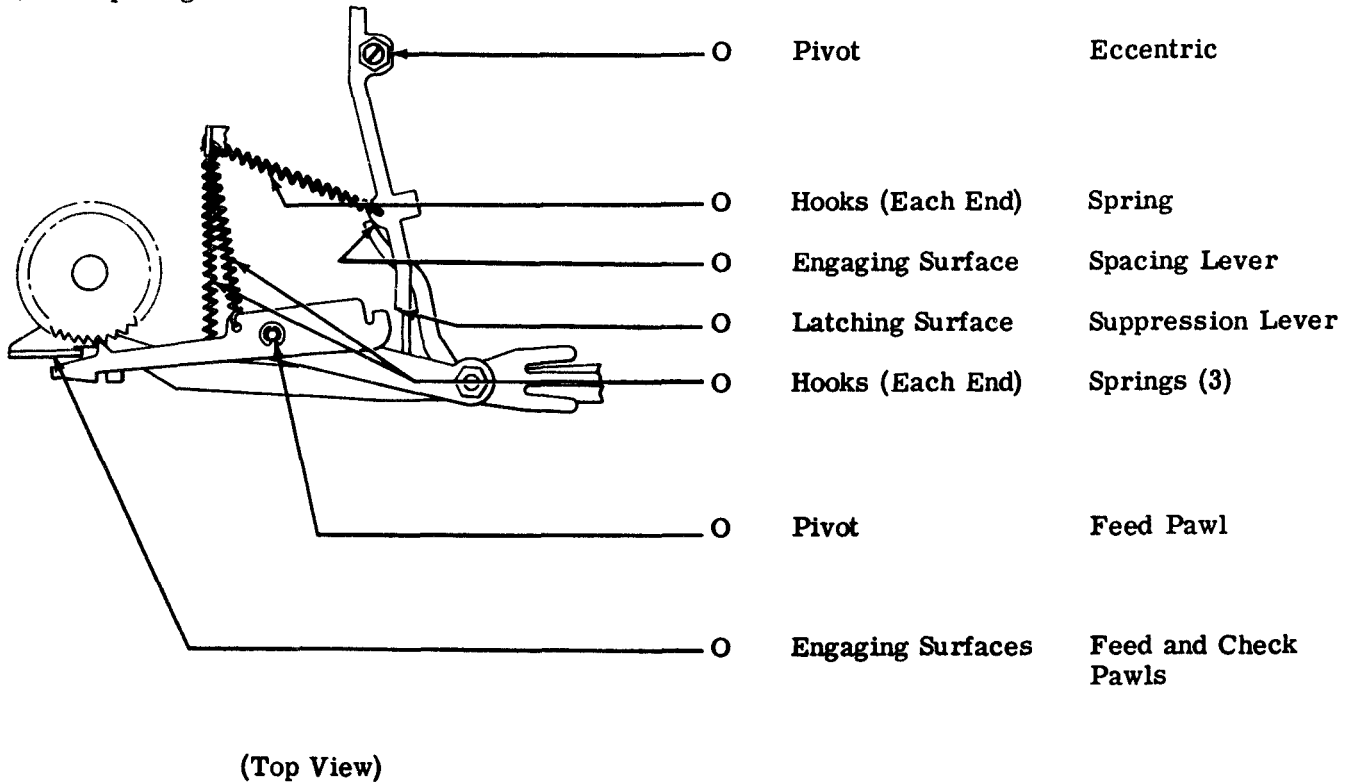

2.26 Spacing Mechanism - 2

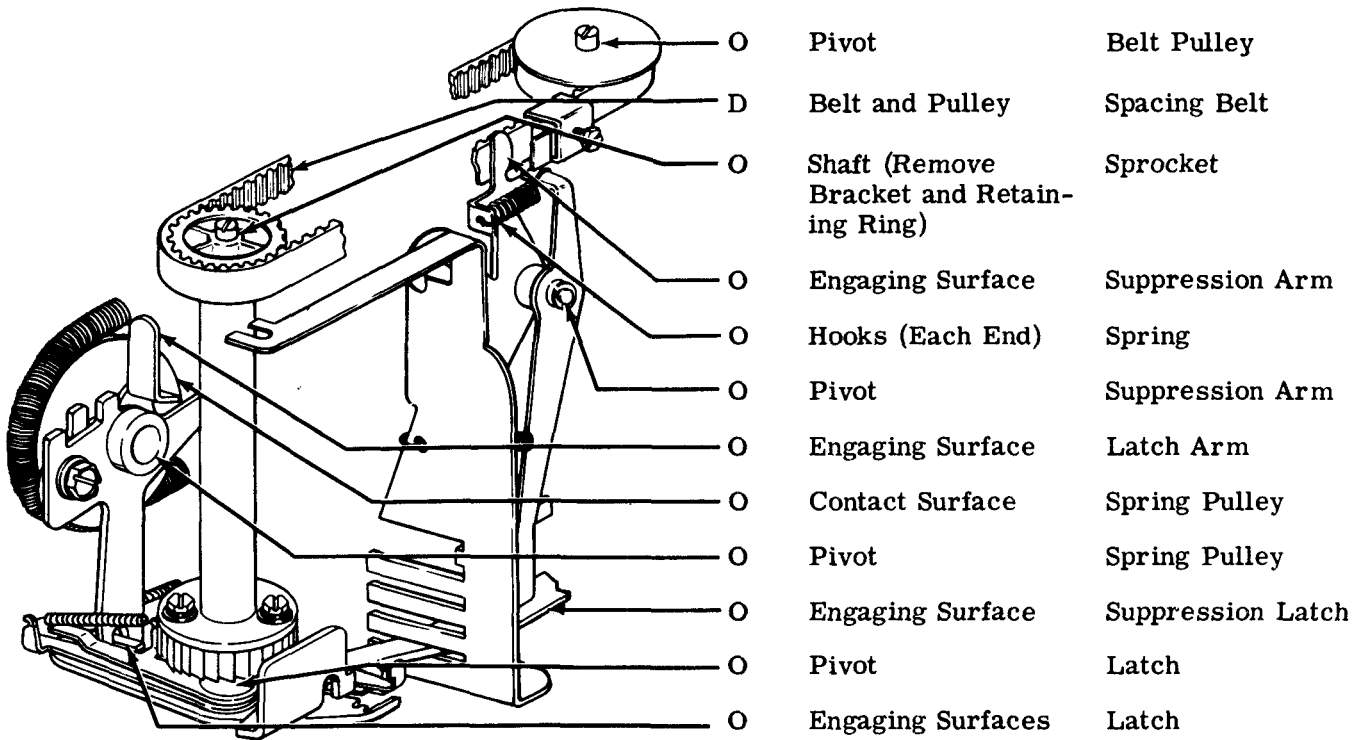

(Left Front View)

2.27 Carriage Area

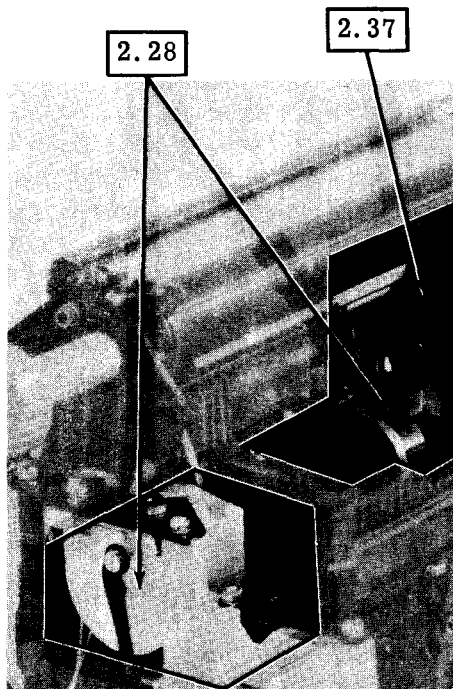

(Left Front View)

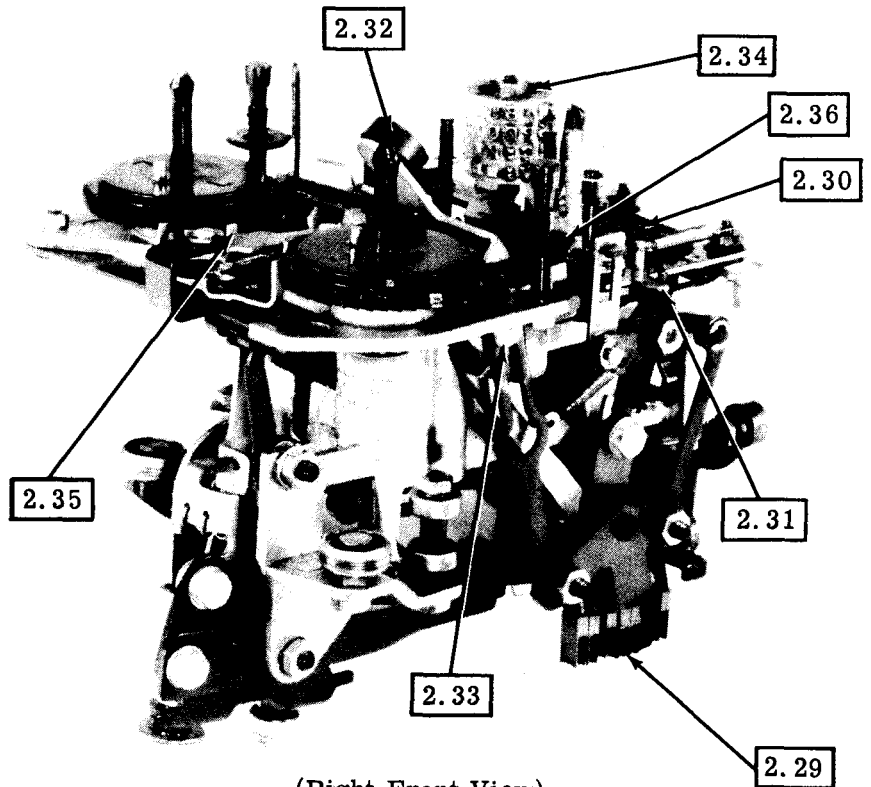

(Right Front View)

Note: Remove ribbon mechanism and carriage return spring before lubricating. For instructions, see the appropriate disassembly and reassembly section.

2.28 Dashpot

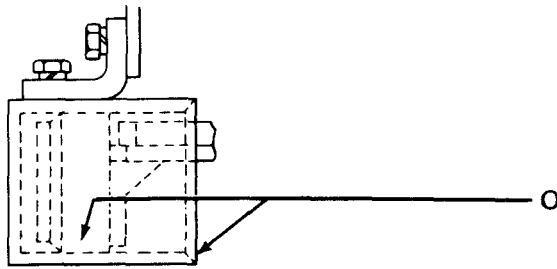

(Front View)

Sliding Surfaces Dashpot and Cylinder
 (Apply with oil dampened cloth. Too much lubricant will cause malfunction.)

2.29 Slides

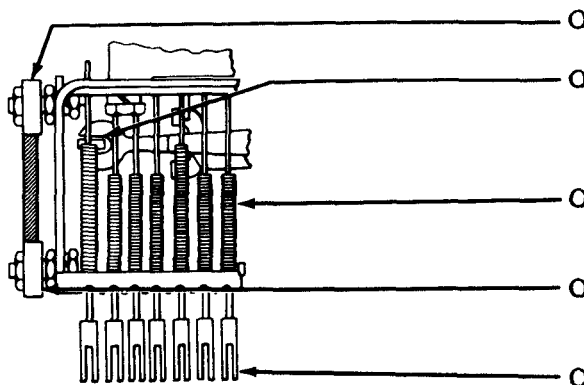

(Left Side View)

Bearing Rear Roller (Top)
 , Engaging Surface Suppression Latch Fork
 Seats (Each End) Slide Guide Springs
 Bearing Rear Roller (Bottom)
 Codebar Contacts Slides

2.30 Slide Guideplates

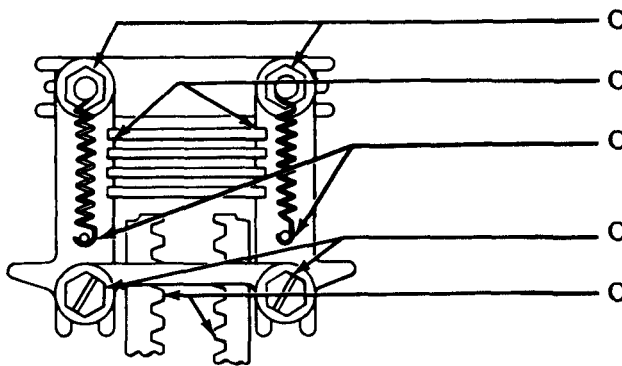

(Top View)

Sliding Contacts Stop Plate
 Engaging Surfaces Stop Slides
 Hooks (Each End) Springs
 Contact Points Slide Guides
 Teeth Pinion Racks

2.31 Drive Arm

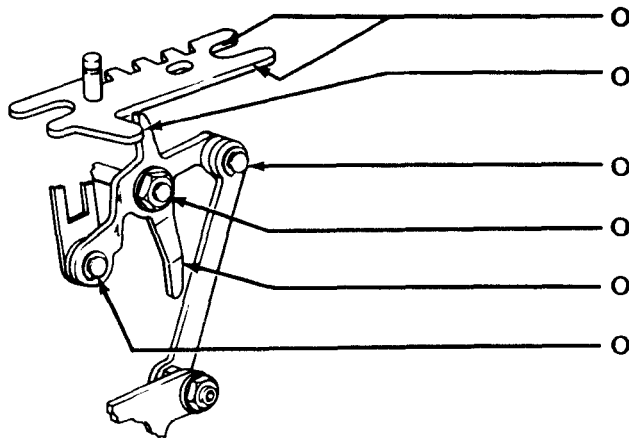

(Right Side View)

- O Contact Surface Plate
- O Contact Surfaces Plate and Drive Arm
- O Pivot Drive Arm
- O Pivot Drive Arm
- O Contact Surface Drive Arm
- O Pivot Link

2.32 Print Hammer

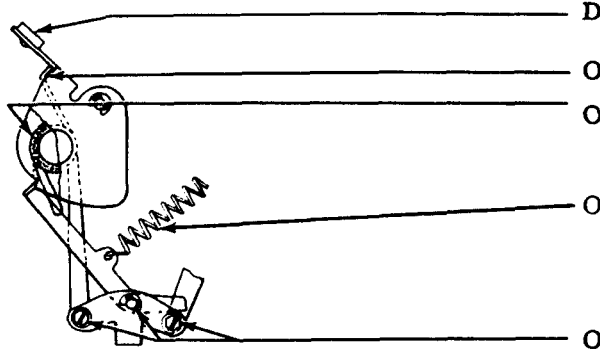

(Right Side View)

- D Surface Print Hammer
- O Ends (2) Torsion Spring
- O Pivots (2) Spring Shaft
- O Hooks (Each End) Spring
- O Bearings (3) Drive Bail

2.33 Reset Arm

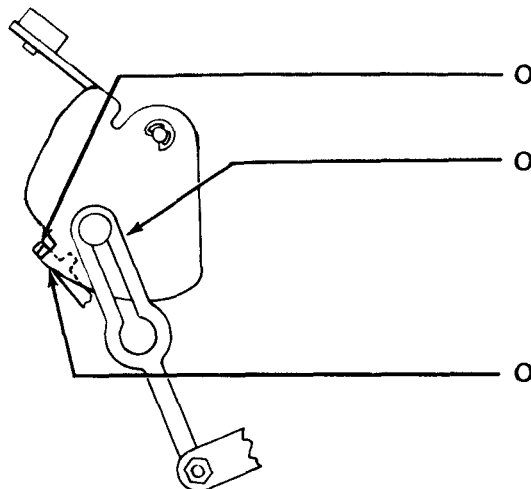

(Right Side View)

- O Latching Surface Trip Lever
- O Sliding Contacts Reset Arm
- O Camming Surface Print Hammer Bail

2.34 Typewheel Mechanism

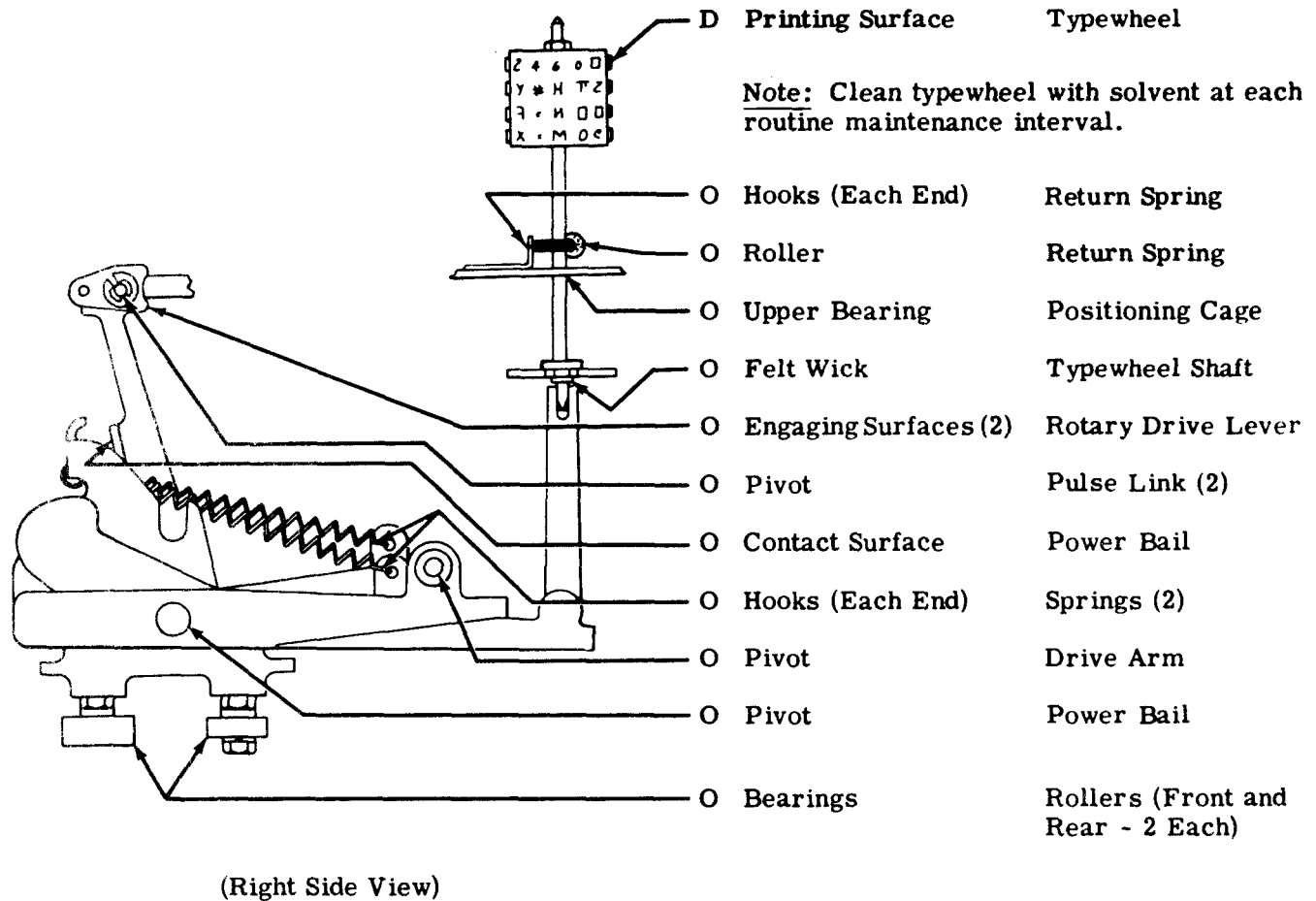

2.35 Ribbon Mechanism

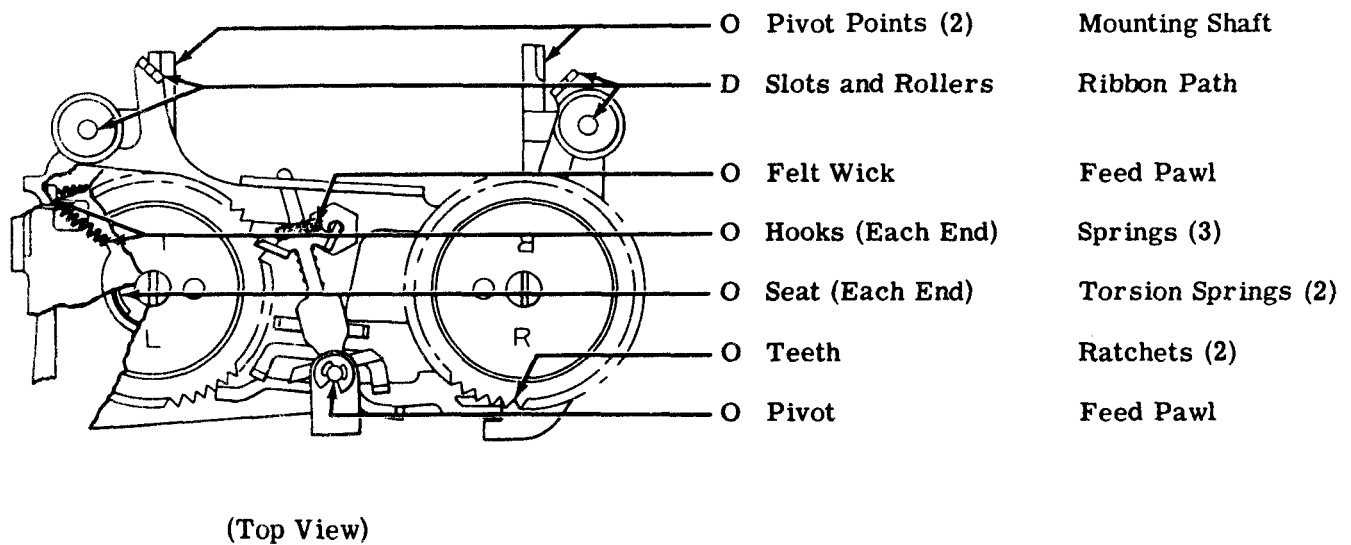

2.36 Ribbon Guide Spring

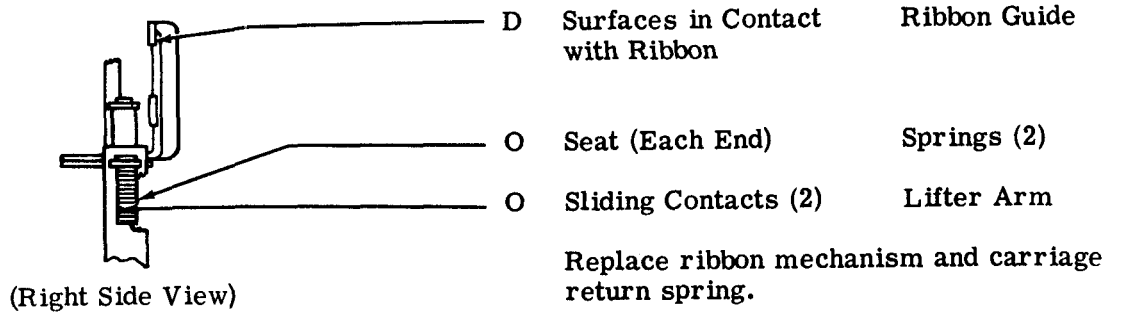

2.37 Carriage Rear Rail

Note: These lubrication instructions apply only to typing units equipped with a TP181304 latch.

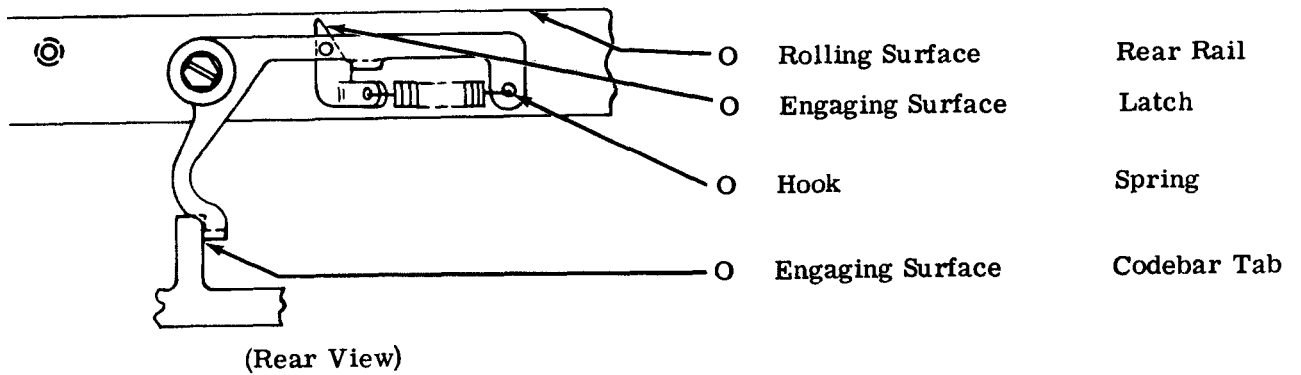

2.38 Selector Area

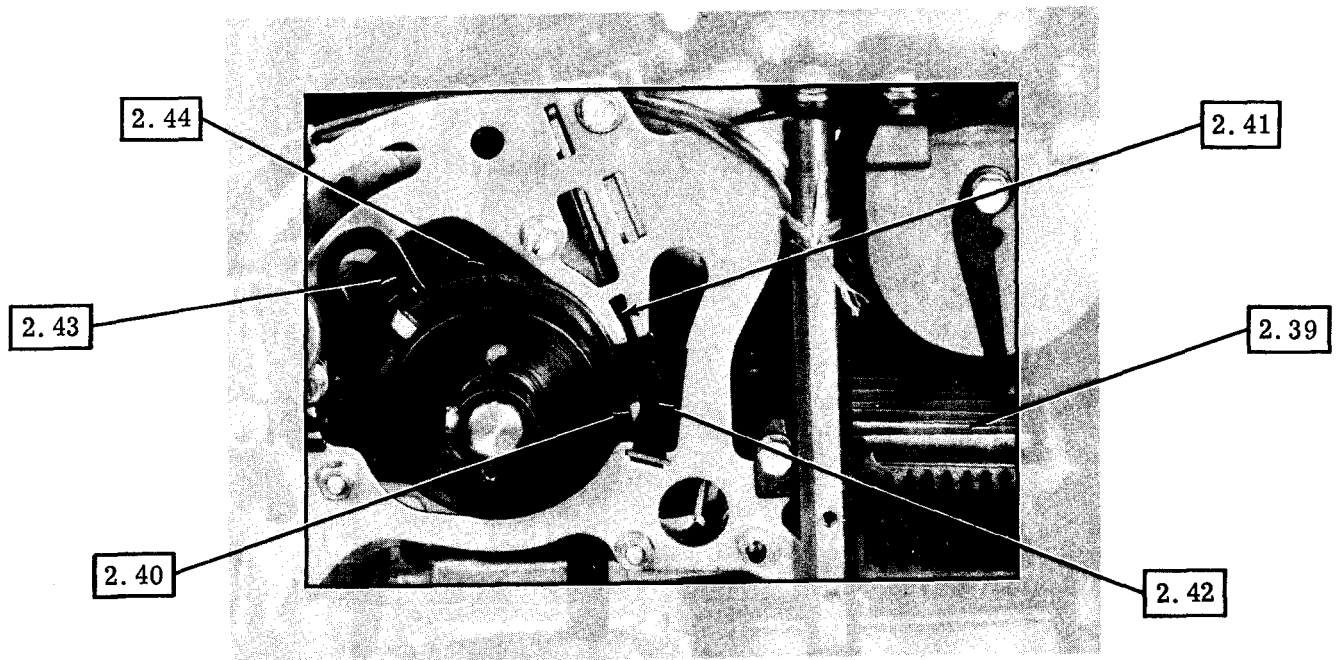

(Left Side View)

2.39 Blocking Levers

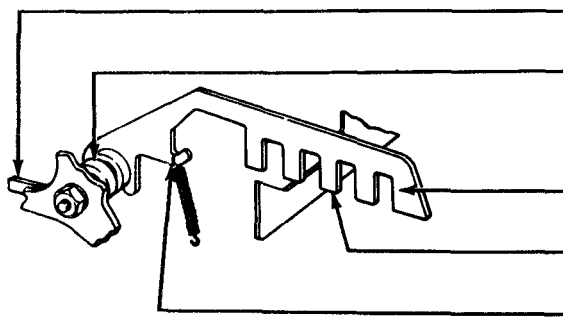

(Left Front View)

- O Contact Surfaces Blocking Levers
- O Pivots Shaft
- O Engaging Surfaces Codebar Slots
- O Contact Surfaces Tines
- O Hooks Springs

2.40 Pushlevers and Stripper Bail

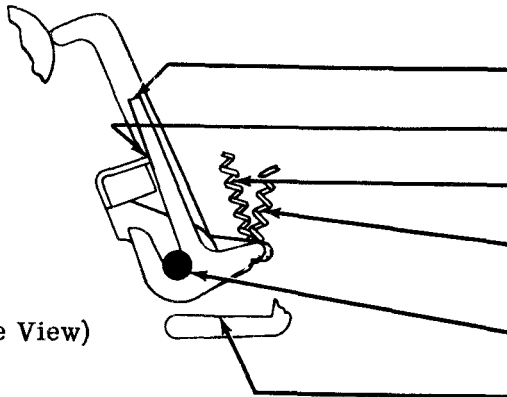

(Left Side View)

- O Latching Surface Pushlevers
- O Contact Surface Stripper Bail
- O Hooks (Each End) Bail Spring
- O Hooks (Each End) Pushlever Springs
- O Pivots Pushlevers
- O Contact Surfaces Blocking Levers

2.41 Armature

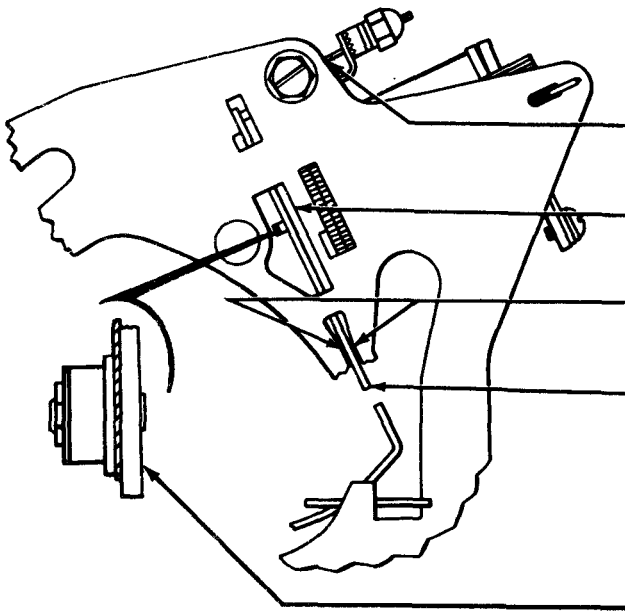

(Left Side View)

- D Hooks Armature Spring
- D Engaging Surfaces Armature
- O Engaging Surfaces Side Plates
- G Engaging Surface Armature
- D Engaging Surface Armature

2.42 Selector Levers

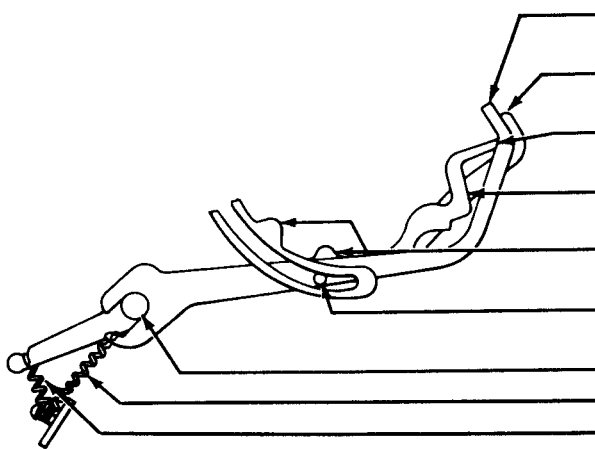

(Left Side View)

- O Tip Start Lever
- O Contact Surface Locklever
- O Contact Surface Selector Levers
- O Engaging Surface Selector Levers
- O Camming Surface Selector Levers
- O Sliding Contact Start Lever
- O Pivots Levers
- O Hooks (Each End) Start Lever Spring
- O Hooks (Each End) Spring (9)

2.43 Latchlever and Trip Lever

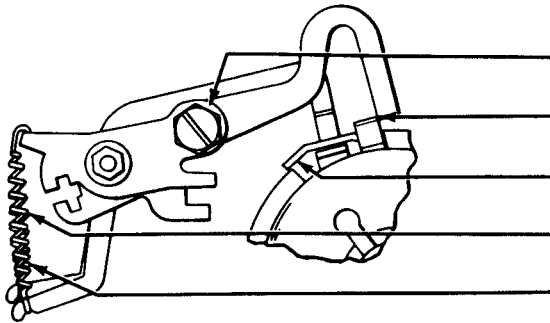

(Left Side View)

- O Pivots (2) Levers
- O Engaging Surface Trip Lever
- O Latching Surface Latchlever
- O Hooks (Each End) Trip Lever Spring
- O Hooks (Each End) Latchlever Spring

2.44 Selector Clutch

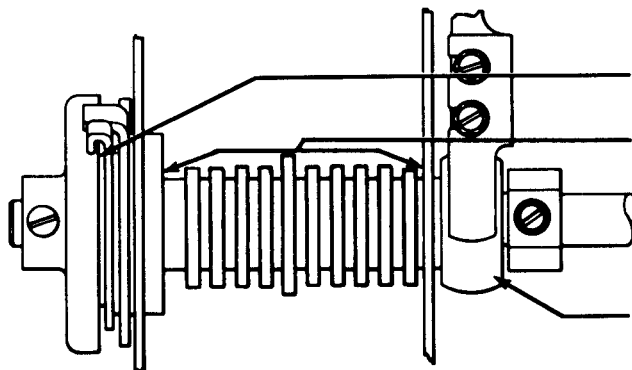

(Top View)

- O* Internal Mechanism Selector Clutch
- O* Camming Surface Selector Clutch
- O Bearing (Each End) Main Shaft

*Refer to 1.05.

FRICION FEED MECHANISMS

2.45 Paper Feed Area

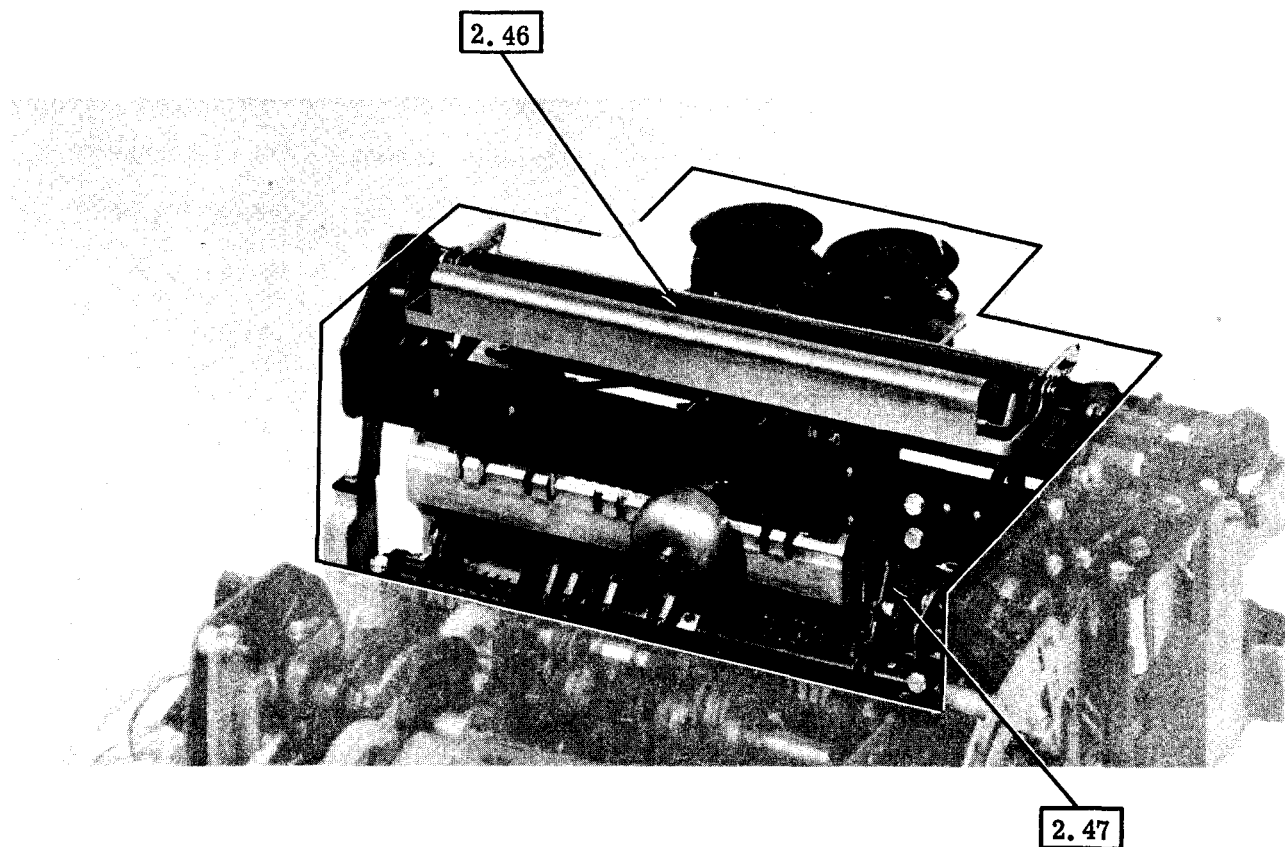

(Rear View)

2.46 Platen

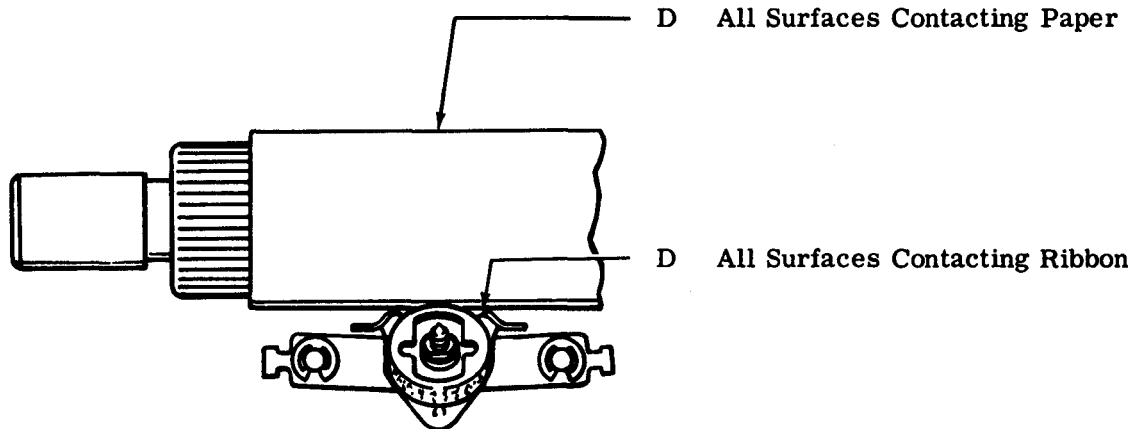

CAUTION: DO NOT CLEAN PLATEN WITH SOLVENTS.

2.47 Line Feed Mechanism

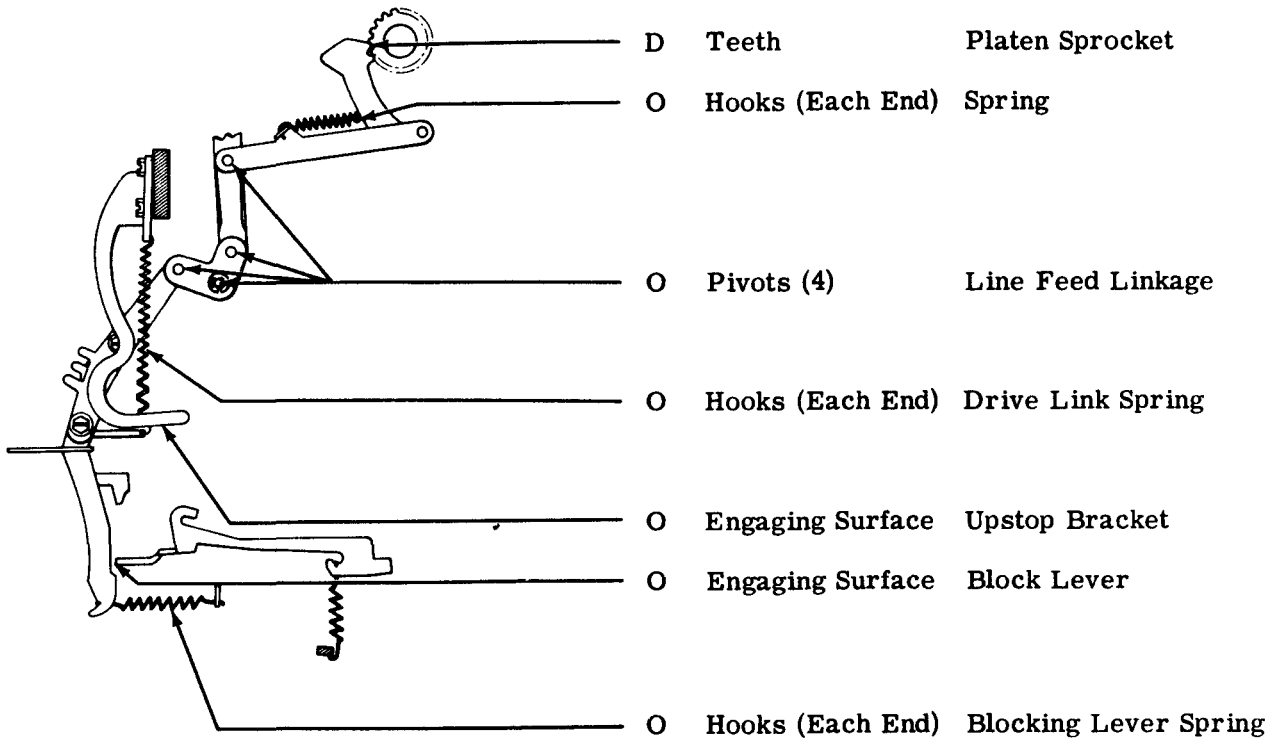

(Left Side View)

SPROCKET FEED MECHANISMS

2.48 Paper Feed Area

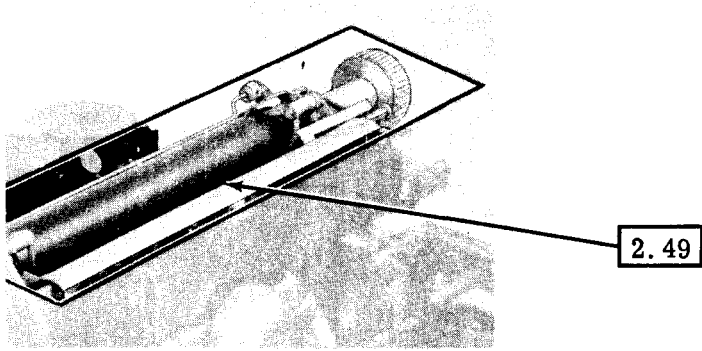

(Right Rear View)

2.49 Platen Mechanism

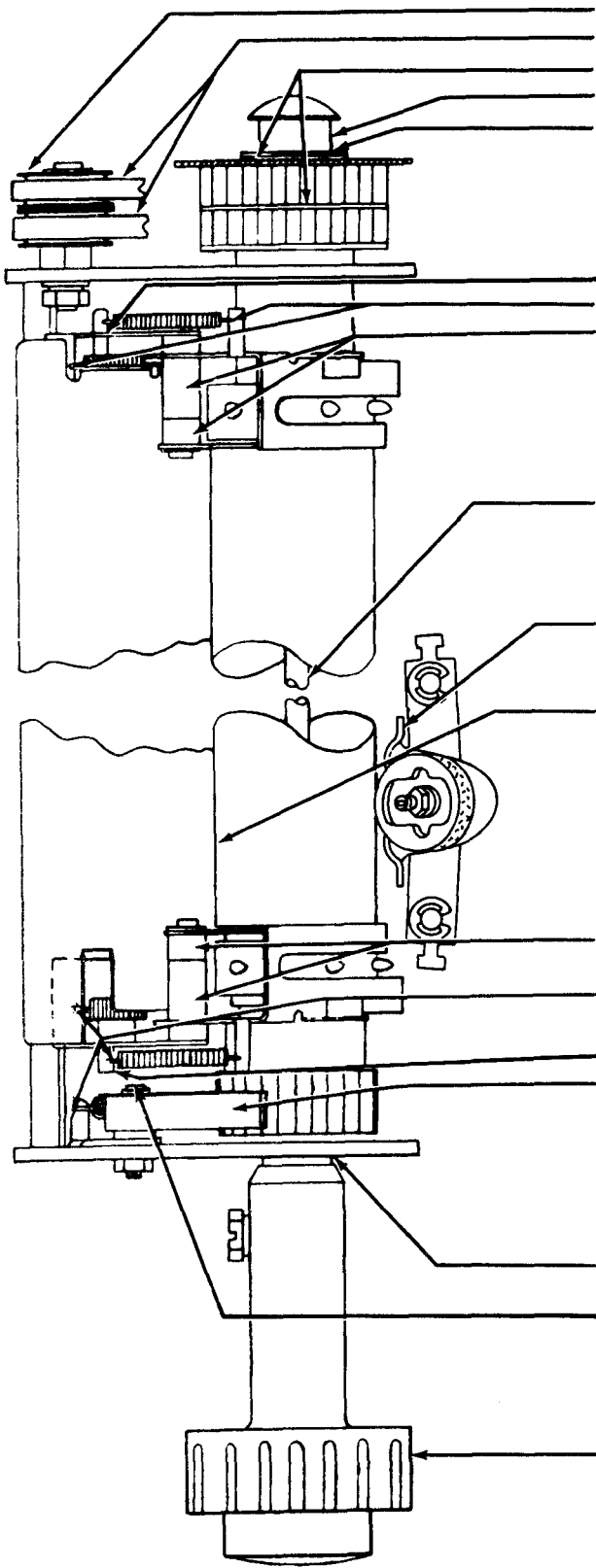

- O Bearing Idler
- D Belts Drive
- O Bearing Pulley
- O Bearing Button
- O Felt Washers Shaft
- (2 Within Shaft)

Note: Shaft must be disassembled. See appropriate disassembly and reassembly section.

- O Pivot Paper Guide
- O Hooks (Each End) Spring
- O Bearing Paper Guide

- O* Bearings (Both Ends) Shaft

Note: Reassemble shaft.

- D All Surfaces Contacting Ribbon

- D All Surfaces Contacting Paper

- O Bearing Paper Guide

- O Hooks (Each End) Spring

- O Pivot Paper Guide

- O Bearing Pawl

- O & G** Bearing Left and Right Plate ←

- O Pivot Detent Lever

- D Bearing Knob

*Refer to 1.05.

**Apply a coat of thoroughly mixed 50 percent KS7470 oil and 50 percent KS7471 grease.

(Top View)

2.50 Platen Drive Area

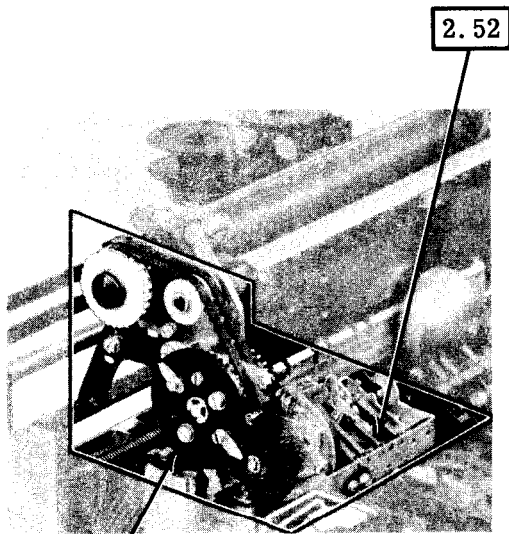

(Right Rear View)

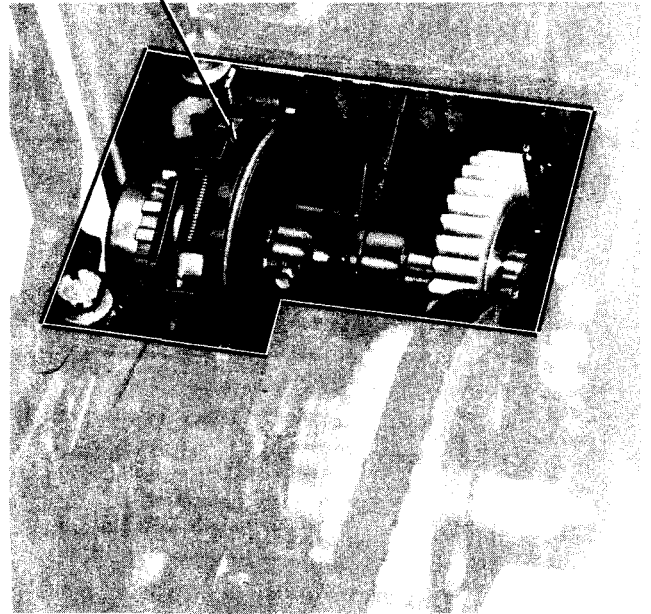

(Left Rear View)

(Form-out mechanism removed for illustration purposes. Removal for lubrication is not required.)

2.51 Cam, Pulley, and Gear Combination

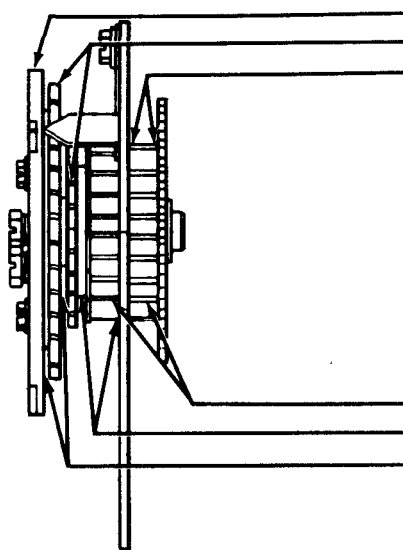

- | | | |
|---|--------------|-----------------|
| O | Cam Surface | Cam Gear |
| O | Gear Surface | Cam Gear |
| O | Bearing | Gear and Pulley |
| | | |
| D | Surface | Pulley |
| O | Bearing | Gear and Pulley |
| O | Bearing | Cam Gear |

(Top View)

2.52 Form-Out Mechanism

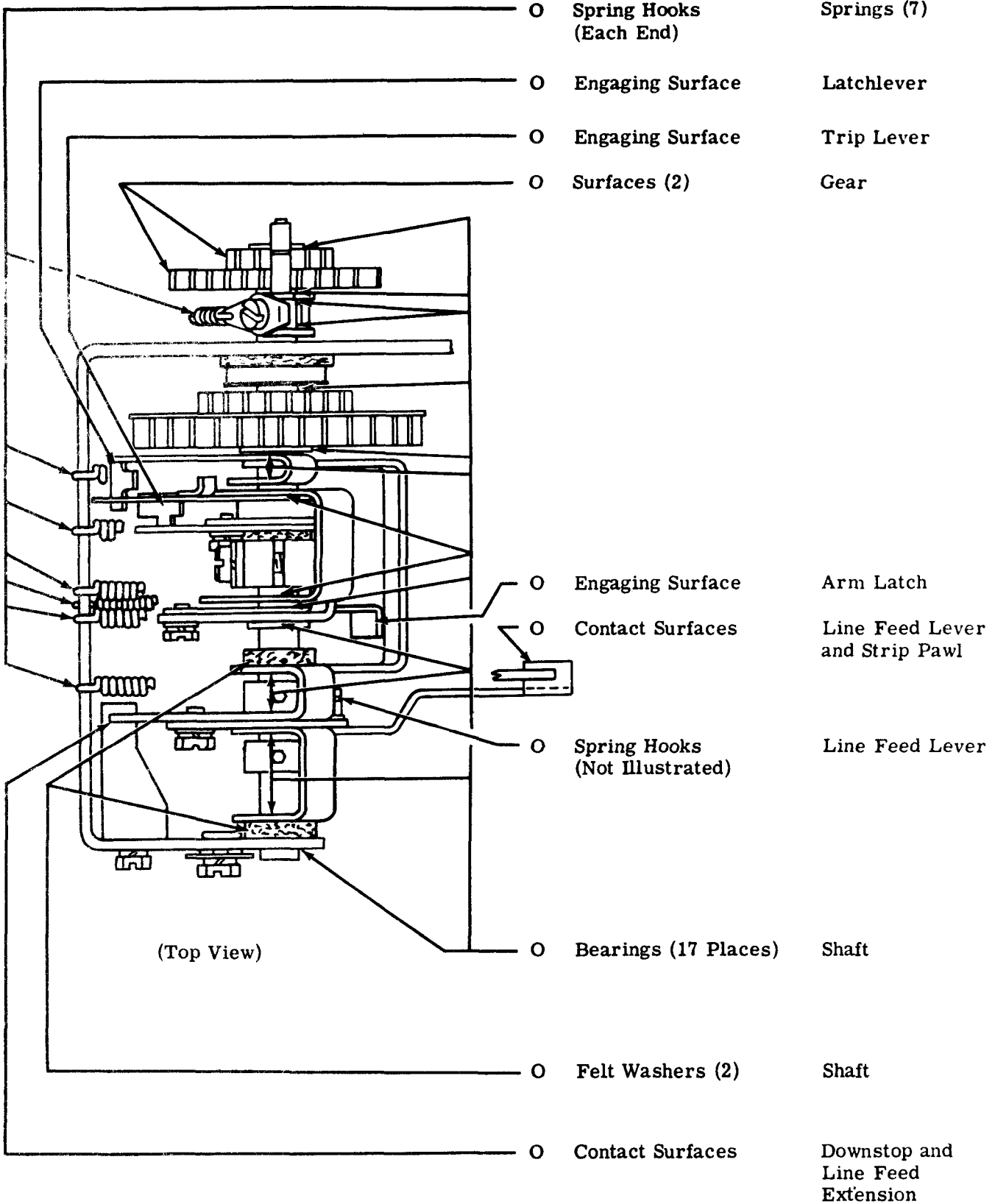

2.53 Line Feed Clutch

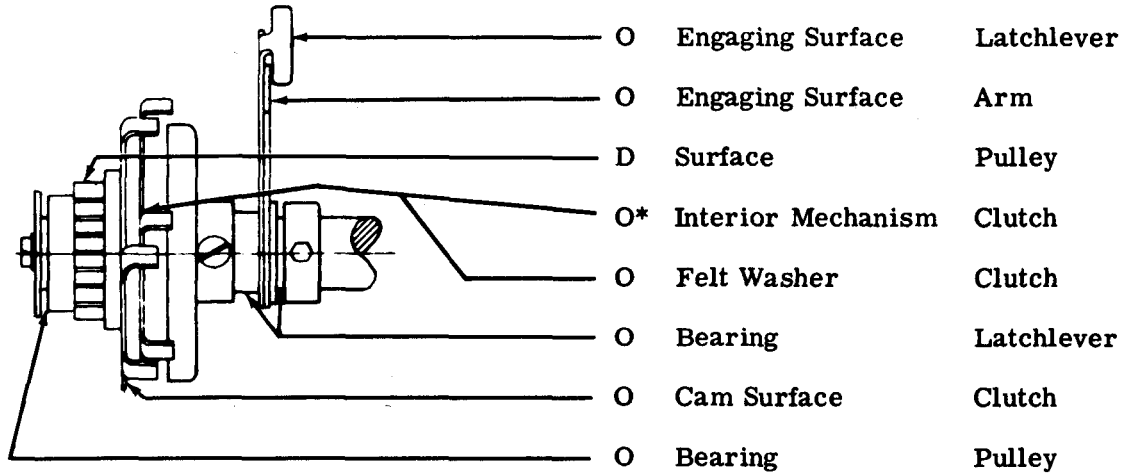

(Top View)

* Refer to 1.05.

3. VARIATIONS TO BASIC UNITS

3.01 Answer-Back Area

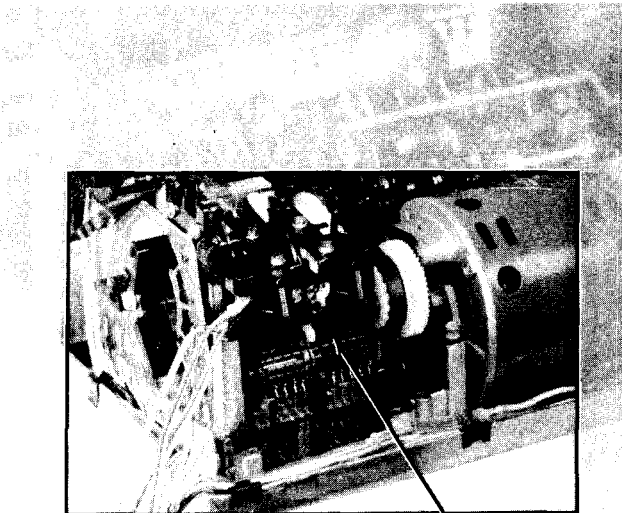

3.03

(Left Rear View)

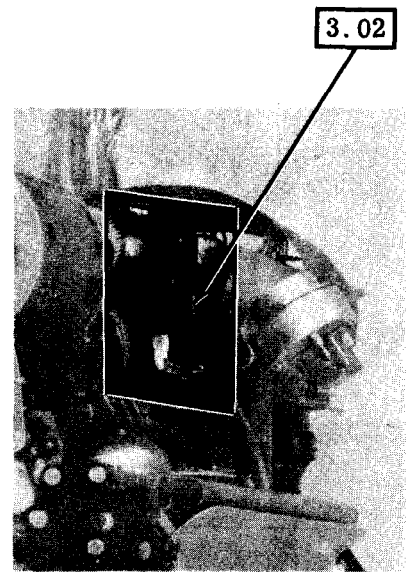

3.02

(Left Side View)

3.02 Trip Magnet

Note: Remove answer-back drum.

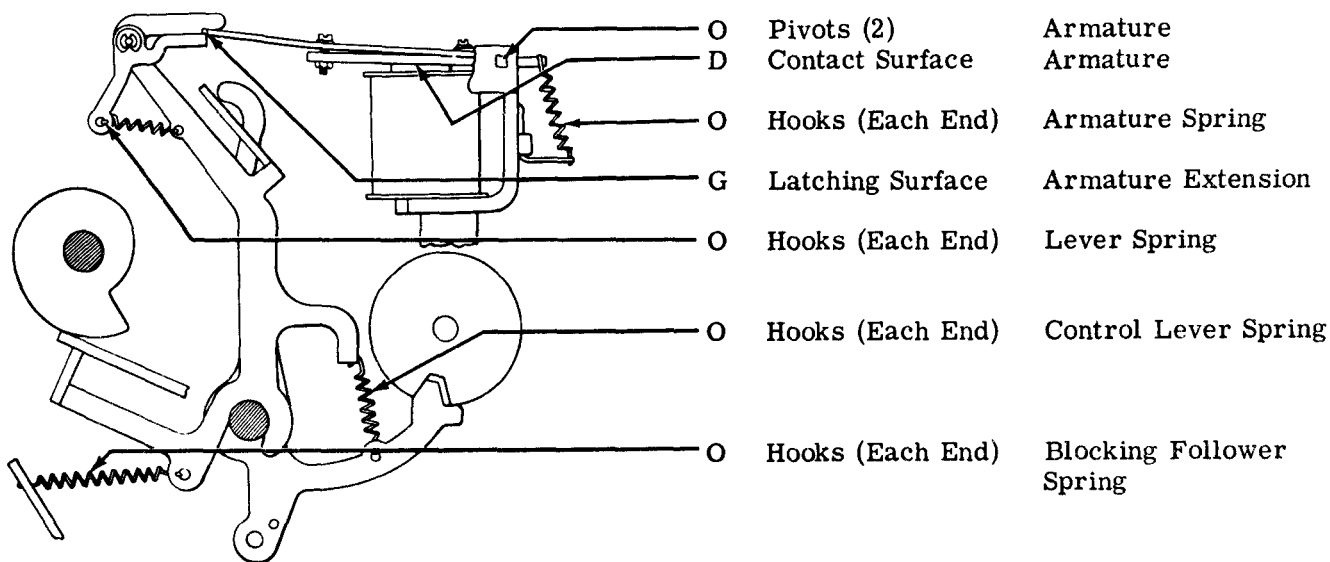

- | | | |
|---|------------------|--------------------------|
| O | Pivots (2) | Armature |
| D | Contact Surface | Armature |
| O | Hooks (Each End) | Armature Spring |
| G | Latching Surface | Armature Extension |
| O | Hooks (Each End) | Lever Spring |
| O | Hooks (Each End) | Control Lever Spring |
| O | Hooks (Each End) | Blocking Follower Spring |

3.03 Answer-Back Mechanism

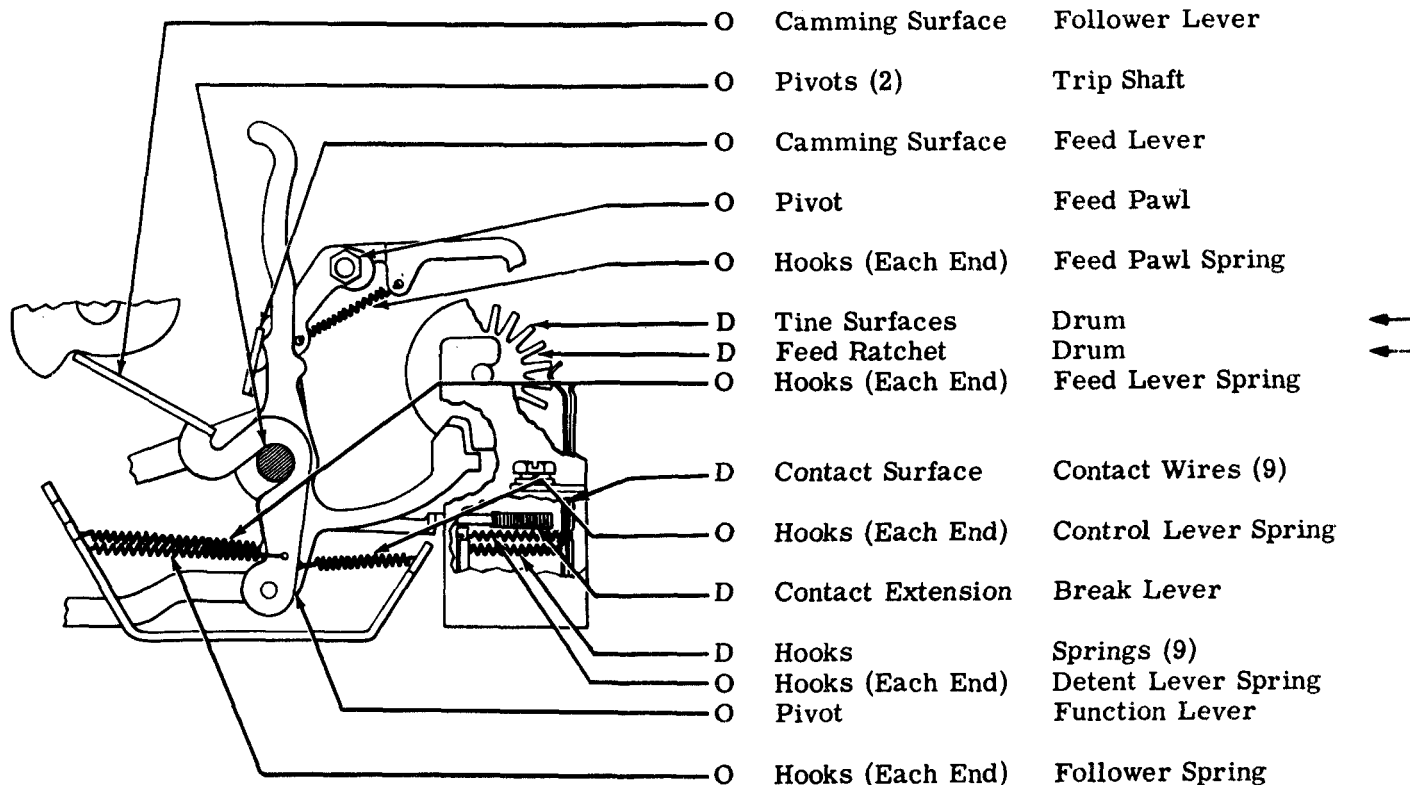

- | | | |
|---|-------------------|----------------------|
| O | Camming Surface | Follower Lever |
| O | Pivots (2) | Trip Shaft |
| O | Camming Surface | Feed Lever |
| O | Pivot | Feed Pawl |
| O | Hooks (Each End) | Feed Pawl Spring |
| D | Tine Surfaces | Drum |
| D | Feed Ratchet | Drum |
| O | Hooks (Each End) | Feed Lever Spring |
| D | Contact Surface | Contact Wires (9) |
| O | Hooks (Each End) | Control Lever Spring |
| D | Contact Extension | Break Lever |
| D | Hooks | Springs (9) |
| O | Hooks (Each End) | Detent Lever Spring |
| O | Pivot | Function Lever |
| O | Hooks (Each End) | Follower Spring |

Note: Replace answer-back drum.

CAUTION: DO NOT CLEAN CONTACT BLOCK WITH SOLVENTS.

3.04 Print Nonprint Mechanism

Note: These lubrication instructions apply to both the magnet operated and solenoid operated print nonprint mechanisms.

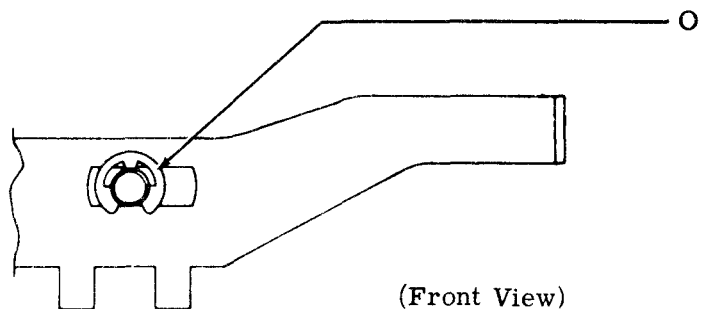

Contact Surface

Nonprint Codebar
Mounting Posts
(Each End of
Codebar)

(Front View)

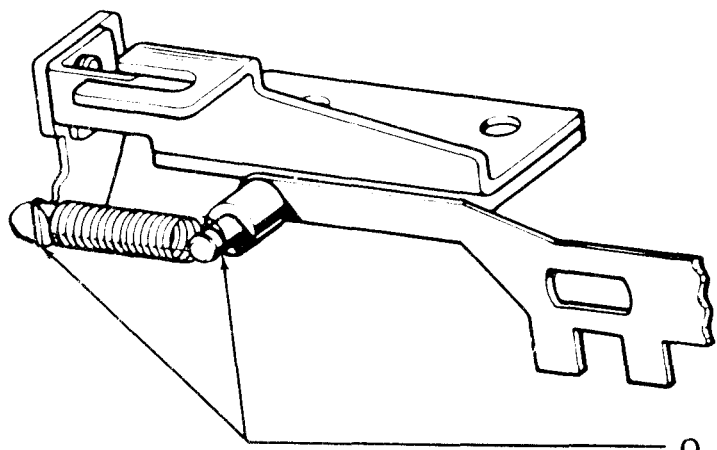

Hooks (Each End)

Nonprint Codebar
Return Spring

(Right Front View)

